



## Limitorque® MX Series B Smart Electric Actuator



*Experience In Motion*



## Flowserve Limitorque actuation systems

Limitorque is an operating unit of Flowserve, a \$3.5 billion-a-year company strongly focused on the automation and support of the valve industry. Flowserve is the world's premier provider of flow management services.

Limitorque has evolved over 80 years since its strategic introduction of a "torque-limiting" design that changed an industry. Flowserve Limitorque offers solutions and automation choices for customers which provide:

- Cost savings from field devices such as electric valve actuators
- Greater operating efficiencies from control room performance sequencing, interlocking and continuous process optimization
- Competitive advantages derived from increased management visibility of databases and networks



SMB (1964)



L120 (1988)



MXb (2020)



MX (2000)

## **MXb actuator: The next generation in smart actuation**

Limitorque MXb: unmatched reliability, precision, advanced diagnostics capabilities and a streamlined user experience.

Flowserve Limitorque introduced the MX electric actuator in 1997 as the first smart actuator that provided uncompromised reliability and performance in a design that was easy to use.

The MX actuator innovations, which were market firsts — a unique absolute encoder that doesn't require battery back-up; LimiGard™ technology; easy-to-use menus in six languages; and the use of Hall effect devices to eliminate potentially troublesome reed switches — have been improved.

The MXb actuator is Limitorque's next-generation, high-performance unit, offering superior reliability, enhanced analytics and an improved user experience.

### **Enhanced user experience**

#### **Up to 50% faster commissioning, setup and operation from a simplified menu structure**

An updated user interface coupled with a simplified, intuitive menu structure makes navigation easy and ensures a smooth, error-free setup process. The new intuitive and configurable menu structure caters to all knowledge and expertise levels by offering multiple configuration options. A quick-setup option ensures rapid and secure basic commissioning, while the advanced setup option allows the actuator to be tailored to the desired application.

#### **Improved legibility owing to a larger, high-resolution LCD screen that extends viewing distance and detail**

The larger, higher-resolution LCD display makes the information and status easily legible from as far as 9.1 m (30 ft). The new LCD display is twice as large as the display on the previous MX model and provides eight times more resolution. The built-in ambient light sensor coupled with smart software allows dynamic brightness and contrast regulation for improved visibility in all lighting conditions.

#### **Enhanced visualization of operational graphs, logs and trends data**

The advanced display uses improved graphics to provide an enriched visualization and data interpretation experience. Real-time torque graphs, alarm and event logs, and other data are accessible in higher-quality resolution.

### **Advanced diagnostics and analytics**

#### **Increased memory with real-time clock (RTC) improves the quality of data captured**

The MXb actuator has 500 times the memory capacity of the previous MX model. A larger memory capacity allows increased data capture and storage for a higher degree of process monitoring, data logging and information feedback. Additionally, the RTC allows data logs to be time stamped in order to support asset management functions and lifecycle analysis.

#### **Advanced diagnostics provide greater process visibility and control**

An enhanced, NAMUR NE107-compliant, diagnostic notification system provides process performance monitoring by alerting the operator of potential future failures with alarm and event conditions through an internationally accepted symbol standard.

### **Improved reliability**

#### **Isolated input/outputs to improve protection from outside interference**

In addition to its non-intrusive construction, the design isolates critical components to ensure higher reliability by addressing electronics survivability, especially in extreme environments where the equipment is subject to electrical shock and interference.

#### **Longer service life from higher-rated components for extended operating ranges and mean time between failure (MTBF)**

High MTBF-rated components and a reinforced housing provide increased robustness and reliable functionality. The use of higher-rated components and materials ensures thermal and resistance ratings that meet and go beyond application needs.

### **Simplified maintenance**

A new electronic connector design removes the need for brackets and hold-downs, making maintenance operations easier and faster. The enhanced connector design ensures robust connectivity throughout the rated seismic and vibration envelope.

### **Backward interchangeability**

The MXb actuator's display and control electronics assembly are backward-compatible and can be easily retrofitted to previous MX actuator models through **conversion kits**.

## The performance you expect with the simplicity you want

### Speed, precision and simplicity

The MXb actuator's control panel features a 240x160-pixel resolution LCD with configurable temperature and ambient lighting compensation control for LCD backlight. The larger, higher-resolution LCD display allows customers the ability to view actuator status and diagnostics in an easy to use, easy to read, graphical format. The built-in ambient light sensor coupled with smart software allows dynamic brightness and contrast regulation for improved visibility in all lighting conditions.

The industry's first multilingual actuator is now capable of configuration in English, Spanish, German, French, Italian, Portuguese, Mandarin, Russian, Bahasa Indonesia, Katakana and Turkish as standard configuration languages. In addition, the LCD can be rotated 180° for better field visibility.

Speed, precision, simplicity and fast set-up are characteristics expected of a smart actuator. Users and valve OEMs demand quick set-up and easy to understand dialog in preferred languages. The ability to either upload new software or download diagnostics is also critical to improving a plant's efficiency. The MXb actuator provides customers with the essential tools for rapid installation and root cause diagnostics.

Precision is expected in a smart actuator. The MX actuator was the first such device developed with an innovative absolute encoder that doesn't require troublesome and unpredictable battery back-up. Flowserve Limitorque's innovative absolute encoder has 18-bit resolution, allows for over 10,000 drive sleeve rotations, and is 100% repeatable. It has BIST (Built In Self Test) enhancements and redundancy.

When a device is designed for BIST, its methodology is such that much of the test functionality is embedded in the device itself. BIST design facilitates a critical component's ability to communicate its actual state for comparison to the expected state. Any deviation from expected values will be reported to the user, either locally at the actuator's LCD screen or over a network device.

Simplicity is expected in a smart actuator. In fact, one of the reasons for using an electric actuator is the simplicity of set-up, installation on a valve, and acquiring diagnostic information. The MXb actuator is the simplest and easiest to use electric actuator.



## Long life and protection

Long life is expected in a smart actuator. There are more than 1,000,000 Limatorque actuators installed around the globe, in every conceivable environment. Many have been functioning for over 50 years. Introduced in 1997, the MX actuator is the Flowserve Limatorque smart actuator that inherits Limatorque's legendary longevity.

In order to last a long time in severe environments, smart actuators must have unparalleled protection. The MX actuator's IP68 enclosure rating is 15M for 96 hours, regardless of whether the unit is weatherproof or explosion-proof. Add other certifications to the list — NEMA 4, 4X, 8 — and the MX actuator is unsurpassed in unit protection.

The MX actuator is double-sealed, which isolates its terminal compartment from the controls environment. Any leakage into the terminal compartment is contained in the compartment.

Additionally, the design isolates critical components to ensure higher reliability by addressing electronics survivability, especially in extreme environments where the equipment is subject to electrical shock and interference.

The MX actuator is powder coated using a polyester resin in Blue Streak color, not only for aesthetics, but also for protection in severe corrosive environments.

## Quality and certifications

Flowserve Limatorque is a global leader in quality manufacturing. All Limatorque plants are certified to ISO 9001 standards, the recognized benchmark for quality all over the world. The same unexcelled use of certified materials is found in the MX actuators as in Limatorque's naval and nuclear-qualified electric actuators. The MX actuator has used synthetic gear oils especially optimized for use with worm gear sets since the first unit was shipped in 1997. It was the first non-intrusive actuator to use rolled worms and electronic controls designed and produced using surface mount technology. A true globally certified device, the MXb actuator meets all pertinent European Directives, including IECEx, ATEX, EMC, Machinery and Noise, and displays the CE mark associated with such compliance.



## Anatomy of MXb multi-turn actuators

Limitorque MX actuators respond to customer needs with advanced features designed for ease of commissioning and use, as well as time and money-saving operational benefits. What sets the MXb actuator apart is the combination of control and reliability enabled by advanced Limitorque technology, plus superior ergonomics and human interfaces for speed, comfort and ease of use.

The MXb actuator's **heavy-duty handwheel** provides backup for manual operation.

The reliable MXb actuator's motor includes **Class F Insulation and three-phase ACV**. It is designed specifically for valve actuator service, with a high starting torque and low inertia to reduce valve position overshoot. Class H is an option for three-phase ACV motors.

Motor gear attachment allows the motor to be removed in one assembly for fast, easy inspection, repair and maintenance.

**Double-sealed housing design** provides a termination chamber that is separate and sealed from the control chamber. Control components are never exposed to the elements during site wiring or because of a faulty cable connection.

External connection block has three power terminals, a ground screw, and 54 control screw-type terminals to **simplify commissioning and upgrades**.

**Long-life gear set** consists of hardened alloy, steel-rolled worm and bronze worm gear immersed in an extended-life synthetic gear oil specifically developed for worm gear operation. It is completely bearing-supported.

Ductile iron thrust base is removable from main actuator housing for **easier valve installation and maintenance**. High-strength, bronze alloy stem nut is removable for machining to suit the valve stem.





**Dec clutch lever** enables the MXb actuator to be placed in manual, handwheel-drive operation. The lever automatically disengages when motor is energized and can be padlocked in the motor position.

Cast aluminum housing is powder-coated for **extreme environments**. Optional coatings are available.

Controls may be powered from an external 24 VDC source as backup for AC power, or it could be used with commissioning. Controls and display will remain active through loss of AC power.

**Torque sensor** derives output from motor speed, temperature and voltage—and shuts off the motor to protect the actuator and valve if the set torque is exceeded. This method of torque sensing indicates Limitorque's commitment to be fully electronic.

**The absolute encoder**, a key that enables MXb actuators to achieve 100% repeatable control, provides optical sensing of valve position with 18-bit resolution. The encoder measures valve position in both motor and handwheel operation. No battery or back-up power supply is required. It is redundant BiST, permitting up to a 50% fault tolerance, ensuring reliable performance in the unlikely event of component failure.

The MXb actuator offers **Bluetooth® LE technology**, which connects, receives and transmits up to 10 m (32.8 ft). Firmware can be downloaded to the actuator easily from a laptop computer.

The **high-resolution control panel display** delivers instant, up-to-the-minute actuator status and valve position in 11 languages. Both historical and real-time graphs can be viewed on the advanced display along with configuration and diagnostic information that includes motor, identification, hardware data, as well as torque profile log reports.

MXb actuators feature a **LimiGard circuit monitor** that is designed for Fail/No-Action protection. LimiGard consists of dedicated circuitry that continually monitors the motor contactor, control relays, internal logic circuits and external command signals to detect and alarm malfunctions. It now includes BiST for true predictive maintenance.

The control chamber includes an **electronic control, monitoring and protection module** mounted on a steel plate. Plug-in connectors allow fast, error-free removal and replacement of the module.

**Local control switches** make setup and calibration easy, using "yes" or "no" responses to straightforward questions, plus they provide the abilities to open, stop and close the actuator and select remote or local preferences. These switches are magnetically coupled, solid state Hall effect devices, which eliminate troublesome and fragile reed switches.

A **rotary knob**, unique to the Limitorque MXb design, facilitates seamless navigation and reduces setup and calibration times. The robust knob allows users the ability to quickly navigate between available menu options and helps in making faster and precision selections.

The Bluetooth® word mark and logos are registered trademarks owned by the Bluetooth SIG, Inc. and any use of such marks by Flowserve is under license. Other trademarks and trade names are those of their respective owners.

## Control and diagnostics

Control is expected in a smart actuator. The MXb actuator is noted for simplifying valve control automation in three critical areas:

- Calibration/set-up
- Normal operation
- Diagnostics and troubleshooting

The MX actuator was the first non-intrusive actuator to equip users with LCD dialog screens in the language of their choice. The new and improved MXb actuator uses a graphical dot matrix display **that doubles the screen size** and offers eight times higher resolution and improves the visibility of the display. The use of this type of LCD permits the support of any language. In fact, in addition to English, Spanish, German, French, Italian and Portuguese, the MXb actuator now includes

six languages — Mandarin, Russian, Bahasa, Indonesia, Katakana and Turkish — with a capacity for even more. The orientation of the text can be configured to rotate 180° and diagnostic graphs displayed for clearer data collection.

Simple “Yes” and “No” responses to dialog questions confirm the set-up of the MXb actuator via solid state Hall effect devices in all knobs. No special tools or remote devices are required. And the MXb actuator is “fit for service”, offering the widest range of configuration menus of any non-intrusive, smart actuator.

The new intuitive and configurable menu structure caters to all knowledge and expertise levels by offering multiple configuration options. A quick-setup option ensures rapid and secure basic commissioning, while the advanced setup option allows the actuator to be tailored to the desired application.



Advanced setup



Main menu



Quick setup



## Nothing exceeds Limitorque MXb actuators for ease and compatibility with valves of all types

### Valves

Limitorque MXb actuators have been designed to accommodate today's wide variety of valve designs and meet international standards for valve and actuator interfaces, including ISO 5210 and MSS SP-102.

MXb actuators are available in a wide variety of configurations to accommodate various applications and valve designs:

**Direct mounting:** The MXb actuator can be directly coupled with valves for torque-only applications. For thrust applications, a separate thrust base is used.

**MX/HBC/WG:** The MXb actuator can be coupled to a WG or HBC worm gear reducer for operation of part-turn valves, such as butterflies, balls, plugs and dampers. This combination provides an output torque capacity of up to 184,260 N m (136,000 ft-lb).

**MX/B320/MT/V and SR:** Rising stem valves may be operated by an MXb actuator coupled to a variety of bevel gear and spur gear reducers. Thrusts up to 1,445 kN (325,000 lb) and torque up to 16,320 N m (12,000 ft-lb) can be accommodated.

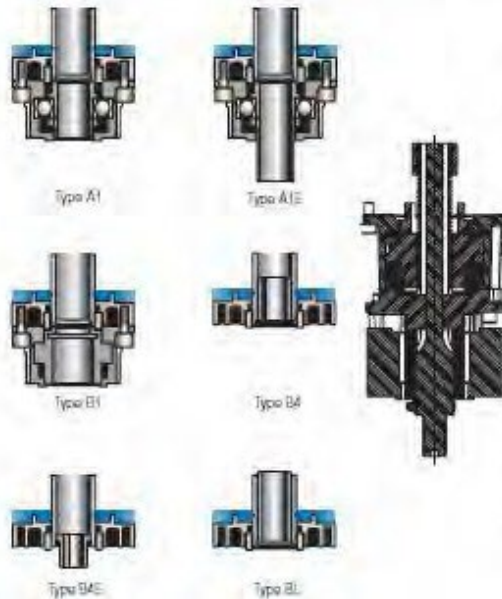
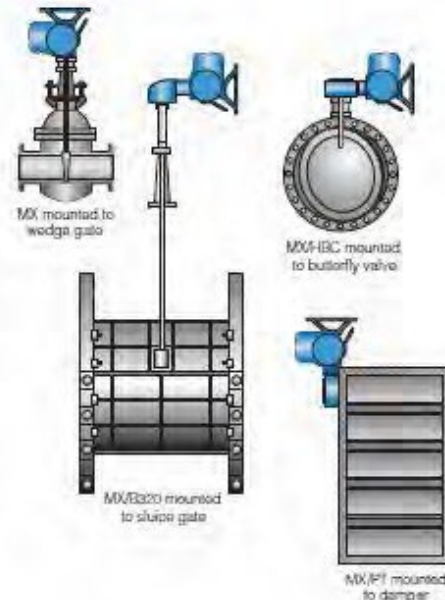

### Couplings

Thrust actuator drive couplings:

- Type A1 – Alloy bronze (thrust)
- Type A1E – Extended bronze nut
- Linear base – Type LB1 (30 N [6,700 lb]) and LB2 (109 N [24,400 lb]) for control and choke valve applications (see LMENFL2360, MX and QXM Linear Base for further information).

Torque-only actuator drive couplings:

- Type B4 – Standard steel bushing
- Type B4E – Extended steel bushing
- Type B1 – Large fixed-bore keyway steel bushing (ISO 5210)
- Type BL – Splined steel bushing for rising rotating stem valves

## Integrity and predictable performance

Smart actuators should have enabling technologies that ensure integrity and dependability. The MXb actuator offers three.

### LimiGard – with BIST

Enhanced reliability for optimal plant operations and reduced troubleshooting costs are the primary benefits of Limitorque's unique smart actuator monitor, LimiGard.

When LimiGard wiring diagrams are followed, LimiGard continually monitors the control relays, internal logic circuits and external command signals, comparing them to reference conditions. This virtually eliminates the possibility that an actuator malfunction can occur without prompt detection and alarm communication. In the event of a malfunction, LimiGard takes over and supervises the actuator's response characteristics, maximizing safety and predictability. Fault Insertion Tests confirm this Fail/No-Action philosophy built into every MXb actuator.

A state-of-the-art electric actuator such as the MXb actuator should include means for verifying and validating that its components are designed with BIST capabilities. Selecting the MXb actuator, which incorporates a high level of BIST, can contribute greatly to the integrity and reliability of process applications and enhance the ability of a safety system to achieve its highest possible rating.

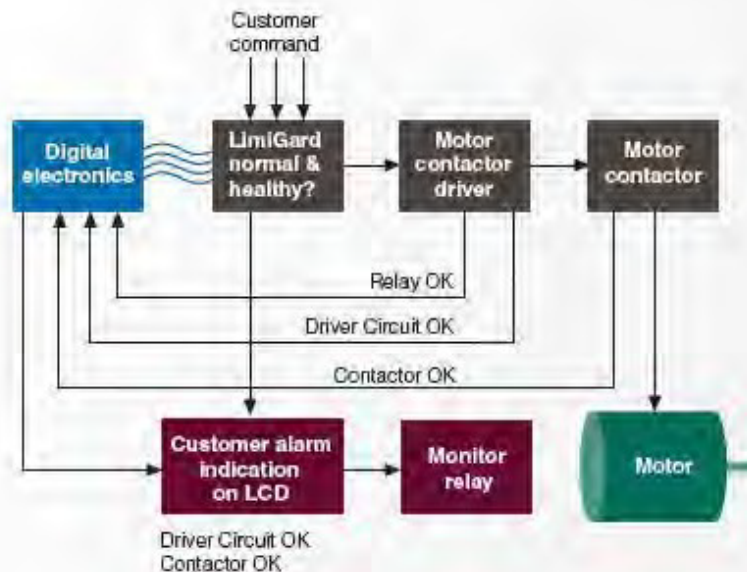

### Absolute position encoder

Limitorque was the first electric actuator supplier to use an absolute encoder which doesn't require battery back-up for positioning. Customers specify absolute encoders for uninterrupted performance, and the MXb actuator meets customer expectations with an improved, 18-bit optical, 100% repeatable device. Position information is accurate with or without electrical power. The 18 bits also means that the span of the MXb actuator's encoder is now almost 10x the original – good for ~10,000 drive sleeve rotations. The encoder has redundant circuits, ensuring performance, even in the event of up to 50% component failure, continuing to provide reliable data while alerting the user to any faults.



### Torque sensing

Torque limiting has been a Limitorque feature for more than 80 years. In fact, the name Limitorque was coined to identify the ability of an electric actuator to "limit torque" to a valve. In the past, electromechanical actuators have sensed torque using a complicated system of springs, switches and cams. The MXb actuator senses torque electronically for use in valve control, overload protection and torque trending. In conjunction with the LimiGard feature, torque is sensed from motor speed, with compensation performed for voltage and temperature variations. The result is highly reliable and predictable torque sensing without the need for the extra components associated with electromechanical torque switches. The MXb actuator is a true smart actuator.

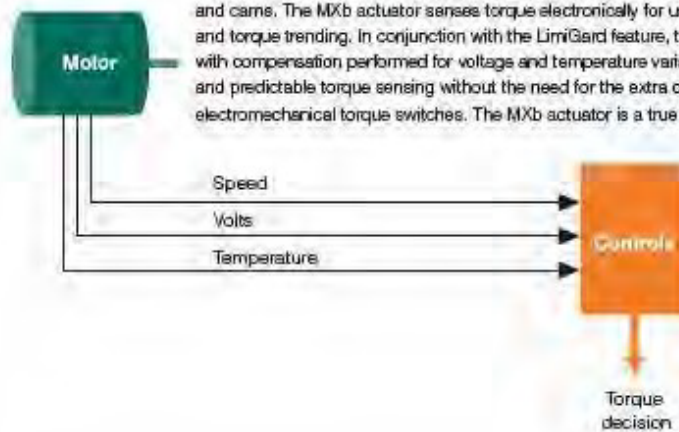

## MXb control, indication, protection and optional features

### Standard features

- **Direct-wired remote control** – Wiring flexibility includes the following standard alternatives to open-stop-close the actuator:
  - Four-wire – Valve can be opened, closed or stopped.
  - Two-wire switched – Single open or closed contact; valve can be opened or closed, but not stopped.
  - Three-wire maintained – Two maintained contacts for self-maintained control. Valve can be opened or closed but not stopped in mid-travel.
  - Three-wire inching – Two momentary contacts; valve can be opened, closed and stopped in mid-travel.
- **Multi-mode control** – Three modes of remote control are permitted when the MXb actuator is configured for multi-control: digital (discrete) control, analog control or network (fieldbus) control. The MXb actuator will respond to the last command received. However, analog (modutronic) control is initiated by either toggling MX User Input 2 (configured for CSE input) or removing and reapplying the 4-20 mA analog signal. Refer to AITB000090 for further information.
- **Monitor relay** – Provides an N/O and N/C contact, representing “Actuator available for remote operation.”
- **Emergency shutdown (ESD)** – A remote, external ESD signal may be applied to the actuator to move the valve to a predetermined user-configured shutdown position, overriding existing control signals.
- **User-defined inputs** – Three user-defined inputs are supplied.
- **Inhibit signals** – External signals may be used to inhibit actuator opening, closing, or both.
- **Control signals** – The control signal can be either 24 VDC or optional 125 VAC; it can be sourced from the actuator or customer supply.
- **Status contacts (4)** – May be set to represent up to 30 actuator conditions.
- **UPS** – Allows for a 24 VDC UPS connection for either early commissioning prior to main power or actuator status and feedback in the event of lost mains power.
- **Negative switching** – When remote control systems require the negative pole of the circuit supply to be switched to positive earth, a simple software change is made.

### Bluetooth LE capable

- Standard low-power wireless communication path to the actuator enables monitoring and configuration of the unit up to 10 m (32.8 ft) in any direction via a Bluetooth LE-compatible PC. FHSS (frequency-hopping spread spectrum) allows a reliable communication link, even in a “noisy” environment, and 128-bit data encryption can be enabled to protect the privacy of the link. A visible blue LED in the controls LCD window on the face of the actuator signifies an active Bluetooth link to the actuator has been established.

### Protection features

- **Autophase protection and correction** – Assures proper open/close directions and monitors and corrects phasing if connected improperly. Prevents operation if a phase is lost.
- **Instantaneous reversal protection** – Incorporates the proper time delay between the motor reversals to reduce current surges and extend contactor life.
- **Motor thermal protection** – A thermistor, placed within the motor, protects against overheating.
- **LimiGard circuit protection** – LimiGard consists of dedicated circuitry that continually monitors the motor controller, control relays, internal logic circuits and external command signals. When the recommended wiring connections are made, it virtually eliminates unexpected, erroneous actuation caused by internal electronic failures and erratic external command signals. Additionally, in the event of malfunction, LimiGard supervises the actuator response, detects the source of the failure, and signals an alarm.

## Optional features

- **Four additional latched contacts** – Additional contacts may be set to represent up to 30 key actuator conditions, for a total of eight contacts.
- **Two-speed timer** – A two-speed pulsing timer may be incorporated to support variable stroke times as configured by the user.
- **Analog position transmitter (APT)** – The APT is an internally powered, non-contacting valve position transmitter that provides a 4-20 mA signal proportional to valve position.
- **Analog torque transmitter (ATT)** – The ATT is a noncontacting, internally powered transmitter that provides a 4-20 mA signal that is proportional to actuator output torque.
- **Modutronic controller** – The Modutronic controller positions the valve in response to an external 4-20 mA command signal. It includes automatic pulsing mode to prevent overshoot at the setpoint. Parameters that may be set easily during configuration include proportional band, dead band, polarity, and action on loss of command signal.
- **Partial stroke and momentary closure ESD** – The partial stroke and momentary closure ESD signals are configurable by the user. It can also be supplied with a momentary closure contact-initiated ESD signal routine with redundant circuitry.
- **Control station (CSE)** – The CSE is a separate control station designed for the operation of inaccessible actuators. It is available with LEDs, Remote/Local and Open/Close selector switches. The CSE may be powered by the actuator's internal supply, provided wire resistance and other external loads do not limit the available signal power presented to the MXb actuator.

- **Solid-state motor reverser (SSMR)** – An SSMR is available when severe modulating operating conditions demand continuous operation.
- **Isolation and load break switches** – Isolation and load break switches can be supplied for the incoming three-phase supply to the actuator. These may be coupled directly to the actuator for weather-proof (WP) applications only or supplied separately for mounting by the user. The enclosure is suitable for WP or temporary submersion service. An explosion-proof (XP) isolation switch is also available for user mounting and is suitable for mounting with all MXb actuators. Please contact factory for availability.



## Network communications

The MXb actuator provides a comprehensive network option portfolio to the user. Network solutions are improved with the addition of HART and TCP/IP to complement Modbus, Foundation Fieldbus H1, DeviceNet, Profibus DP\_V1 and Profibus PA. The MXb actuator provides the user with predictable, reliable and safe operation for years to come, in applications which are subject to the most rigorous requirements and environmental extremes.

### DDC Modbus (distributed digital control) communication

DDC is Flowserve Limitorque's digital communication control system that provides the ability to control and monitor up to 250 actuators over a single twisted-pair cable. The communication network employs Modbus protocol on an RS-485 network and is redundant. Redundancy assures that any single break or short in the communication cable will not disable any actuators. Each actuator has included an addressable field unit that communicates over the twisted-pair network and executes open, close, stop, ESD and GO TO position commands. The field unit also transmits all actuator status and alarm diagnostic messages over the same communication network.

#### DDC network

- Single-ended loop (consult factory)
- Modbus protocol
- High-speed – up to 19,2 k baud

### Master Station IV

MXb actuator units equipped with DDC can be controlled via Flowserve Limitorque's Master Station IV. It includes:

- Network control (up to 250 devices)
- Host interface – Industry standard Modbus Rtu, ASCII, UDP, and TCP/IP protocols and control
- 165.1 mm (8.5 in) TFT touch-screen display for network configuration status
- Configurable polling sequence priority
- Network time protocol for time synchronization of alarms diagnostic data to host device
- Modular hot-swappable redundant design; modules can operate independently or be externally coupled to form redundant communications
- Email notifications of alarm conditions
- Data/event logging



### Foundation Fieldbus communication with device type manager (DTM) technology

The MXb actuator can be fitted with Foundation Fieldbus protocol that complies with the IEC 61158-2 Fieldbus H1 standard. The field unit device is able to support several topologies such as point-to-point, bus with spurs, daisy chain, tree, or a combination of these. The FF device has network features that include:

- Link Active Scheduler (LAS) that controls the system
- High-speed communications up to 31.25 kbits/sec
- Publisher-subscriber communication
- Input and output function blocks
- Device descriptions
- Network communication
- Configurable by user

Link Active Scheduler communication: Fieldbus segments have one active LAS at a given time, which is the bus arbiter, and does the following:

- Recognizes and adds new devices to the link
- Removes non-responsive devices from the link
- Schedules control activity in, and communication activity between, devices
- Regularly polls devices for process data
- Distributes a priority-driven token to devices for unscheduled transmissions
- DTM technology includes PID (proportional integral derivative) and partial stroke (PS) features

### PROFIBUS DP V1 communication with DTM

The MXb actuator can be fitted with Profibus DP\_V1 protocol field units that comply with EN50170 Fieldbus Standard for RS-485 communications. The device supports several topologies such as point-to-point, bus with spurs, daisy chain, tree, or a combination of these. The PB device has network features that include:

- High-speed communications up to 1.5 Mbps
- Master-to-slave communication
- Standby communication channel
- Analog and digital input and output function blocks
- Device descriptions configurable by the user
- High-Speed Data Exchange – Startup Sequence
- Power On / Reset – Power On / Reset of master or slave
- Parameterization – download of parameters into field device (selected during configuration by the user)
- I/O configuration – download of I/O configuration into the field device (selected during configuration by the user)
- Data exchange – cyclic data exchange (I/O Data) and field device reports diagnostic
- Redundant Profibus DP with single or multiple – master communications

## PROFIBUS PA communication with DTM

A Profibus PA protocol is available and complies with EN50170 Fieldbus Standard and Fieldbus physical layer per IEC 61158-2 for communications. The device supports several topologies such as point-to-point, bus with spurs, daisy chain, tree, or a combination of these. The PB device has network features that include:

- High-speed communications up to 31.25 kbits/s with Manchester coding
- Master-to-slave communication
- Bus powered for 9 to 32 VDC and 15 mA per actuator
- Standby communication channel
- Analog and digital input and output function blocks
- Device descriptions
- Configurable by user

The Profibus DP-V1/PA DTM V 1.0 is a software component that contains device-specific application information. The DTM can be integrated into engineering and FDT frame applications, such as stand-alone commissioning tools or asset management systems that are equipped with FDT interfaces. FDT technology is independent from any specific communication protocol, device software or host system, allowing any device to be accessed from any DCS host through any protocol.

## DeviceNet

DeviceNet complies with CAN-based protocol and provides the following features:

- DeviceNet Group 2 Server implementation
- Master-to-slave communication
- Bus-powered network interface allows power alarm information to be communicated when actuator loses main power; the actuator does NOT drop off the network when power is lost
- Standard polled I/O connection
- Standard bit strobed I/O connection
- Standard change of state / cyclic I/O connection
- Standard exploit connections defined as:
  - Various assembly objects and sizes that allow the network user to determine how much data to transfer to accommodate network installation data throughput requirements
  - Automatic baud rate detection
  - Node address configurable via local setup menu or via the remote network user
  - Broadcast or group network originated ESD support

## HART Communication with DTM

- Complies with HART Communication Protocol Specification (Document HCF\_SPEC-13) for Revision 7.3
- Digital signal on conventional 4-20mA analog signal
- 1,200 bps binary phase – continuous Frequency-Shift-Keying
- Master-Slave communication method
- Point-to-point or multi-drop network topology
- Distances up to 1800 meters/network (up to 15 devices)
- EDDL (IEC 61804-2, EDDL) with methods for all supported common practice and device-specific commands



## MXb series performance ratings for units 05 through 150

MX-05 through MX-40 (three-phase: 50 Hz/380, 400, 415 and 440 Volt; 60 Hz/208, 230, 380, 460, 480, 525, 575 Volt)

MX-85 through MX-150 (three-phase: 50 Hz/380\*, 400 and 415 Volt; 60 Hz/380, 460, 575 Volt)

\*380/50 multiply by 0.9

Output Speed (RPM)				MX-05		MX-10		MX-20		MX-40		MX-85		MX-140		MX-150	
				Rated Output Torque													
60 Hz		50 Hz		ft-lb	N m	ft-lb	N m	ft-lb	N m	ft-lb	N m	ft-lb	N m	ft-lb	N m	ft-lb	N m
18	15	55	75	125	170	225	305	440	597	n/a	n/a	n/a	n/a	n/a	n/a	n/a	n/a
28	22	55	75	125	170	225	305	440	597	650	1,153	1,500	2,036	n/a	n/a	n/a	n/a
40	33	55	75	125	170	225	305	440	597	1,225	1,662	1,700	2,307	n/a	n/a	n/a	n/a
52	43	55	75	125	170	225	305	440	597	1,150	1,561	1,800	2,171	n/a	n/a	n/a	n/a
77	65	48	65	107	145	178	241	345	468	650	1,153	1,200	1,628	n/a	n/a	n/a	n/a
100	131 <sup>1</sup>	84	110 <sup>1</sup>	39	53	89	121	148	201	296	388	600	814	815	1,105	1,500	2,036
155	170 <sup>1</sup>	127	143 <sup>1</sup>	41	56	89	121	140	190	260	353	450	611	650	882	1,150	1,561
200	165	34	46	73	99	114	155	210	285	n/a	n/a	n/a	n/a	n/a	n/a	n/a	n/a

Note 1: MX-85, MX-140 and MX-150

Type A Couplings	lb	kN	lb	kN	lb	kN	lb	kN	lb	kN	lb	kN	lb	kN	lb	kN
Thrust ratings (lb/kN)	8,000	35	15,000	66	25,000	111	38,000	169	50,000	222	75,000	333	75,000	333	75,000	333
B4 Base (Torque Only)	lb	kg	lb	kg	lb	kg	lb	kg	lb	kg	lb	kg	lb	kg	lb	kg
Weights (lb/kg)	52	24	85	29	109	49	133	60	250	114	300	136	431	182		

A1 Base (Thrust Only) Weight	lb	kg	Linear Base Weight	
MX-05 & MX-10	9	4	LB1	
MX-20 & MX-40	29	13	LB2	
MX-85 w/ F16/FA16 base	72	33	24	11
MX-140 & MX-150 w/ F25/FA25 base	111	50	65	29.5

### Maximum stem capacity

Type A Couplings	in	mm	in	mm	in	mm	in	mm	in	mm	in	mm	in	mm
Type A1	1.26	32	1.57	40	2.36	60	2.64	67	3.50	88	3.50	88	3.50	88
Type A1E (extended nut)	1.26	32	1.57	40	2.36	60	2.64	67	3.50	88	3.50	88	3.50	88
Type B Couplings (Torque Only) <sup>2</sup>	in	mm	in	mm	in	mm	in	mm	in	mm	in	mm	in	mm
Type B4	1	25.4	1.25	30	1.94	50	2.2	55	2.88	73	2.88	73	2.625	65
Type B4E (extended)	0.75	19	0.91	22	1.56	41	1.78	46	2.25	57	2.25	57	2.625	65
Type B1 (fixed bore) <sup>2</sup>	n/a	42	n/a	42	n/a	60	n/a	60	n/a	n/a	n/a	n/a	n/a	n/a
Type B1 (splined)	6 & 38 Splines	6 & 38 Splines	6 & 36 Splines	6 Splines	n/a	n/a	n/a	n/a	n/a	n/a	n/a	n/a	n/a	n/a
Maximum Bore and Keyway	in	mm	in	mm	in	mm	in	mm	in	mm	in	mm	in	mm
Maximum bore (B4)	1	25.4	1.25	30	1.94	50	2.2	55	2.88	73	2.88	73	2.625	65
Maximum key dimensions	1/4 sq.	8 x 7	1/4 sq.	10 x 8	1/2 x 3/8	14 x 9	1/2 x 3/8	16 x 10	5/8 x 7/8	18 x 11	5/8 x 7/8	18 x 11	5/8 x 7/8	18 x 11
Maximum bore (B4E)	.75	18	0.91	22	1.56	41	1.78	46	2.25	56	2.25	56	2.50	65
Maximum key dimensions	3/16 sq.	6 x 6	1/4 sq.	8 x 7	3/8 sq.	12 x 8	1/2 x 3/8	14 x 9	1/2 x 3/8	16 x 10	1/2 x 3/8	16 x 10	0.625 sq.	18 x 11

Note 2: Maximum bore for Type B couplings may require rectangular keys.

	MX-05	MX-10	MX-20	MX-40	MX-85	MX-140	MX-150
Mounting base (MSS SP-102/ISO 5210)	FA10/F10	FA10/F10	FA14/F14	FA14/F14	FA16/F16	FA25/F25	FA25/F25
Handwheel ratio (STD/Optional)	Direct	Direct/8:1	Direct/12:1	Direct/24:1	16/48	16/48	16/48
Side-mounted handwheel efficiencies	n/a	52%	54%	51%	53%/51% <sup>4</sup>	53%/51% <sup>4</sup>	53%/51% <sup>4</sup>

## MXb actuator standard and optional features

Limiterorque MXb electric valve actuators are designed for the operation of ON-OFF and modulating valves. They include a three-phase electric motor, worm gear reduction, absolute encoder, electronic torque sensor, reversing motor contactor, electronic control, protection and monitoring package, handwheel for manual operation, valve interface bushing, 240x160 pixel resolution LCD and local control switches — all contained in an enclosure sealed to NEMA 4, 4X, 6 and IP68. XP enclosures can also be provided when required. All MXb actuators comply with applicable European Directives and exhibit the CE mark.

### Power transmission and lubrication

All mechanical gearing components are bearing supported, and final drive (output) consists of a hardened alloy steel worm and alloy worm gear. All gears are immersed in an oil bath lubricated with a synthetic oil designed specifically for extreme pressure worm and worm gear transmission service. Special lubricants are available for operation in temperatures of less than -30°C (-22°F). Consult factory.

Lubrication and temperature range	Synthetic brand
Standard lubrication: -30°C to 70°C (-22°C to 158°F)	Mobile SHC 323
Optional food-grade lubrication: -30°C to 70°C (-22°C to 158°F)	Dow Molykote

### Motor, three-phase ACV

The MXb actuator's motor is a three-phase squirrel cage designed for electric valve actuators. It is specifically designed for the MXb actuator and complies with IEC 84, S2-33% duty cycle at 33% of rated torque. The motor is a true bolt-on design with a quick-disconnect plug that can be changed rapidly without sacrificing motor leads. It is equipped with a solid-state motor thermistor to prevent damage due to temperature overloads.

On-off modulating
<ul style="list-style-type: none"> <li>Standard insulation class is F to IEC 34; S4_50% for stated operating times is 100 to 600 starts per hour.</li> <li>SSMR: 600 to 1,200 starts per hour; IEC 34, S4_50% is 1,200 starts per hour.</li> </ul>

The MXb actuator's motor permits a global range of three-phase voltages to be connected without modification. The motor can energize, provided either of the listed voltages are connected:

Phase/frequency	Application Voltage
Three-phase, 60 Hz	208, 220, 230, 240, 380, 440, 480, 490, 550, 575
Three-phase, 50 Hz	380, 400, 415, 440, 525

### Electronic control modules

#### Non-intrusive

The MXb actuator is non-intrusive, which means that all calibration/configuration is possible without removing any covers and without the use of any special tools. All calibration is performed in clear text languages; no icons are used. All configuration is performed by answering the "YES" and "NO" questions displayed on the LCD. "YES" is signaled by using the OPEN switch and "NO" by using the CLOSE switch, as indicated adjacent to the switches.

#### Double-sealed terminal compartment and terminal block

All customer connections are located in a terminal chamber that is separately sealed from all other actuator components. Site wiring doesn't expose actuator components to the environment. The internal sealing within the terminal chamber is suitable for NEMA 4, 6 and IP68 to 15M for 96 hours. The terminal block includes screw-type terminals: three for power and 54 for control. Customer connections are made via conduits located in the terminal housing.

Three standard conduit openings (NPT threads standard; M optional)
(2) – 1.25 in NPT or M32 (optional)
(1) – 1.5 in NPT (standard) or M36 (optional)
(1) – 1.0 in NPT (optional) or M25 (optional)

### Controls

The controls are all solid state and include power and logic circuit boards and a motor controller that performs as the motor reverser, all mounted to a steel plate and attached in the control compartment with captive screws. All internal wiring is flame resistant, rated 105°C (221°F), and UL/CSA listed.

The controls are housed in the ACP (actuator control panel) cover, and the logic module uses solid-state Hall effect devices for local communication and configuration. A 240x160 resolution, graphical LCD is included to display valve position as a percent of open, 0 to 100% and current actuator status. Red and green LEDs are included to signal 'Opened' and

'Closed,' and are reversible, and a yellow LED to indicate 'Valve Moving.' A blue LED is included to indicate when the Bluetooth feature is recognized by an external Bluetooth LE-enabled device and a white LED to indicate 'Overtorque Fault' or 'Torque Seated'. A padlockable LOCAL-STOP-REMOTE switch and an OPEN-CLOSE switch are included for local valve actuator control.

Using the knobs and LCD screen, the MXb actuator is configurable in 11 languages: English, Spanish, French, German, Portuguese, Italian, Mandarin, Russian, Bahasa Indonesia, Turkish and Katakana. A rotary knob provides ease of menu maneuvering.



### S contacts for remote indication

As standard, four latching status contacts rated 250 VAC, 5A and 30 VDC, 5A are provided for remote indication of valve position, configured as 1-N/O and 1N/C for both the open and closed positions. The contacts may be configured in any of the selections depicted in the "Actuator Status Message" column.

"S" Contact AC	"S" Contact DC
5 Amps @ 250 VAC	5A @ 30 VDC

Actuator Status Message	Function
"Closed"	Valve closed "(0% OPEN)"
"Opened"	Valve open "(100% OPEN)"
"Closing"	Valve closing
"Opening"	Valve opening
"Stopped"	Valve stopped in mid-travel
"Valve Moving"	Either direction
"Local Selected"	Red selector knob in "LOCAL"
"Motor Overtemp"	Thermistor range exceeded
"Overtorque"	Torque exceeded in mid-travel
"Manual Override"	Actuator moved by handwheel
"Valve Jammed"	Valve can't move
"Close Torque SW"	Torque switch trip at "CLOSED"
"Open Torque SW"	Torque switch trip at "OPEN"
"Local Stop/Off"	Red selector knob at "STOP"
"Lost Phase"	One or more of the incoming supply lost
"ESD Signal"	Signal active
"Close Inhibit"	Close inhibit signal active
"Open Inhibit"	Open inhibit signal active
"Analog IP Lost"	4-20 mA not present
"Remote Selected"	Red selector in "REMOTE"
"Hardware Failure"	Indication
"Network Controlled"	Permits relay control via DDC, FF, or other network driver
"Function"	LimitGuard circuit protection activated
"Mid-Travel"	Valve position, 1 to 99% open
"CSE Control"	CSE station in LOCAL or STOP and controls actuator
"PS Active"	Partial stroke test in operation
"PS Passed"	PS test complete and successful
"PS Failed Target"	PS test did not achieve target value
"PS Failed Returns"	PS test did not return to start position
"PS"	Partial stroke, active if "PS" configured
"Run Load Alarm"	Single phase only
"DPTS Open"	Open torque switch trip (open torque seat or open overtorque)
"DPTS Close"	Close torque switch trip (close torque seat or close overtorque)



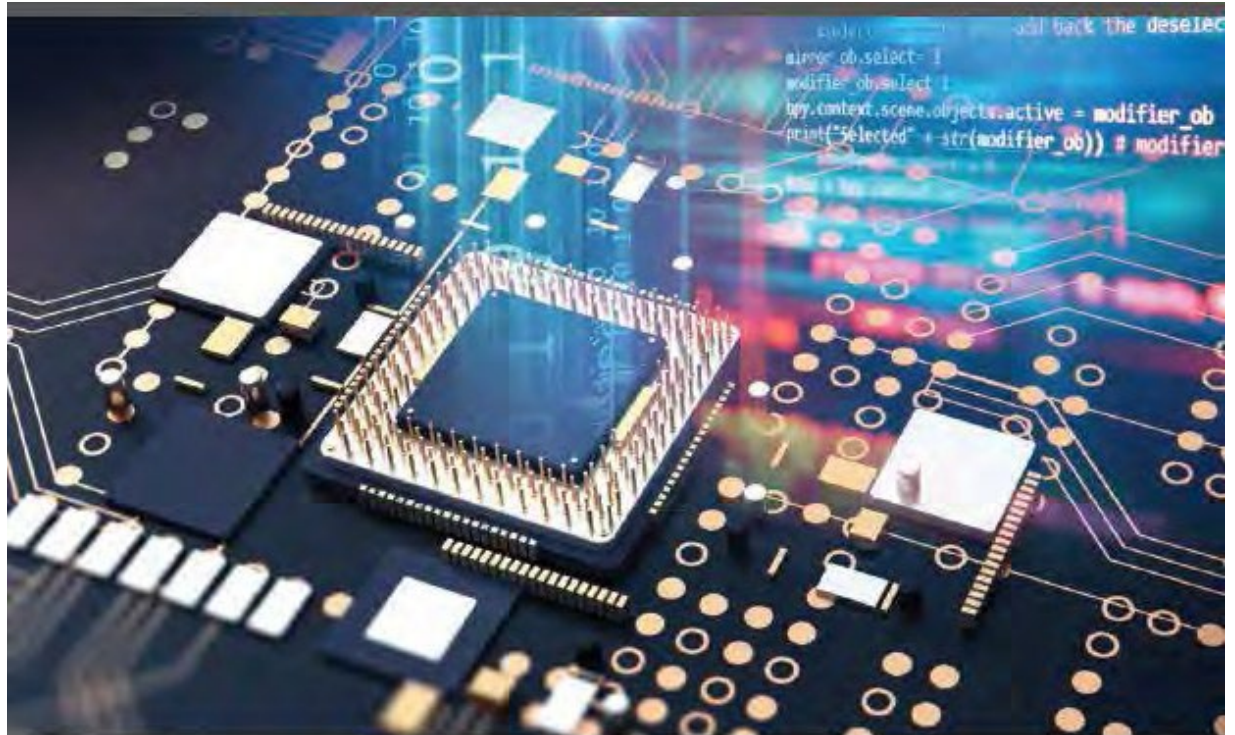

#### Monitor relay for remote indication

A monitor relay is included as standard and trips when the actuator is not available for remote operation. Both N/O and N/C contacts are included, rated 250 VAC, 5 A and 30 VDC, 5 A. The monitor relay is hard set for lost phase, valve jammed and motor overtemp, but can be additionally configured for local knob movement, overtorque, inhibits active or ESD active. The yellow LED will blink when the monitor relay is active. The user can disable the monitor relay, if necessary.

Monitor Relay AC	Monitor Relay DC
5 Amps @ 250 VAC	5A @ 30 VDC

#### Remote control

Discrete remote control (user supplied) may be configured as two, three or four wires for Open-Stop-Close control. Remote control functions may be powered by external 24 VDC, 110 VAC, or the actuator's internal 24 VDC supply or optional 110 VAC supply. The internal supplies are protected against over-current and short circuit faults and utilize optical isolation to minimize electromagnetic interference. Discrete control provides isolated commons for up to three selections.

Signal Threshold for Voltage Values	Maximum Load
5.0 VAC/VDC maximum 'OFF'	24 VDC + 2 mA
19.2 VAC/VDC minimum 'ON'	110 VAC + 10 mA

#### Speed control

The MXb actuator permits operational speeds in either Open and Closed directions to be set independently of each. It also has an industry-leading span for the optional two-speed timer.

Two-Speed Timer Span "On" Pulse	Two-Speed Timer Span "Off" Pulse
0.5 to 20 seconds (0.5 sec. increments)	1.0 to 200 seconds (1.0 sec. increments)

## Software

### LimiGard

A dedicated circuit to prevent undesired valve operation in the event of an internal circuit fault or erratic command signal is included as standard on each Limatorque electric actuator. A single point failure will not result in erratic actuator movement nor will an open or short circuit in the internal circuit board logic energize the motor controller. The command inputs are optically coupled and require a valid signal pulse width from at least 250 to 350 ms to either turn on or off. In the event of an internal circuit fault, an alarm is signaled by tripping the monitor relay and through LCD indication. The control module also includes an auto reversal delay to inhibit high-current surges caused by rapid motor reversals.

### Phase detection and correction (three-phase)

A phase correction circuit is included to correct motor rotation faults caused by incorrect site wiring or phase switching in the event of a power down. The phase correction circuit also detects the loss of a phase and disables operation to prevent motor damage. The monitor relay will trip and an error message is displayed on the LCD screen when loss of phase occurs.

### Multi-mode remote control

The MXb actuator is capable of being configured for multi-mode remote control, which permits discrete wiring for either two, three or four wires, or network (Fieldbuses) for Open-Stop-Close control and responds to the last signal received. The actuator can also distinguish analog control for modulating applications. The QX and MX products from Limatorque are the only smart actuators with such features.

### ESD

An emergency shutdown (ESD) provision is included in each actuator, and the MXb actuator has up to three configurable inputs for ESD. The ESD signal(s) can be selected to override any existing signal and send the valve to its configured emergency position. Provision for an isolated common is standard.

### Inhibits

The MXb actuator has as standard provisions for inhibit movement and also contains up to three configurable inputs. Provision for an isolated common is also standard.



### Advanced diagnostics

The MXb actuator incorporates advanced diagnostics that provide greater process visibility and control. It features an enhanced, **NAMUR NE107-compliant**, diagnostic notification system that provides higher process control by alerting the operator of alarm and event conditions through an internationally accepted symbol standard.

The MXb actuator tracks the actuator's environment and performance through a sophisticated set of sensors and **monitors for any deviations** that might be outside of specified tolerances. Voltage, operation, torque and vibration, to name a few, are some of the diagnostics tracked to give the user a more active approach to maintaining their equipment before failures or damage occur.

The MXb actuator provides **time-stamped data logging** capability to track local and remote move commands as well as events and alarms. The data logger event and alarm list is configurable and can store thousands of historical actions time-stamped by an RTC. The RTC is backed up by a battery with an operating life of 10+ years.



The MXb actuator also has a high-resolution graphical display that allows for local display of the actuator's diagnostics. The MXb actuator can display profiling of all sensor data with relation to position. It can display live and historical torque profiles with the ability to inspect the profile for exact torque and position values.

### Valve and actuator position sensing

Valve position is sensed by an 18-bit, optical, absolute position encoder with redundant position-sensing circuits designed for BIST. Each of the position-sensing circuits is redundant, facilitating BIST. The BIST feature discerns which failures will signal a warning only and which require a warning plus safe shutdown of the actuator. Open and closed positions are stored in permanent, non-volatile memory. The encoder measures valve position at all times, including both motor and handwheel operation, with or without power present, and without the use of a battery. The absolute encoder is capable of resolving  $\pm 7^\circ$  of output shaft position over 10,000 output drive rotations. This design permits continuous monitoring of valve position during motor and handwheel operation. The encoder is 100% repeatable and requires no backup power source for operation. The output is used to control the open and closed valve positions and measure and report valve position, as well as provide local and remote position feedback. The positioning accuracy is better than 99% for valves requiring 50 or more turns.

- Maximum actuator turns = 10,000
- Resolution =  $\pm 7$  degrees

### Valve and actuator torque sensing

The MXb and QX are the only electric actuators that sense torque electronically. A microprocessor calculates output torque from motor speed, voltage and temperature. Torque limit may be set from 40 to 100% of rating in 1% increments. A "Jammed Valve Protection" feature is included to de-energize the motor if the output torque requirement exceeds the boost torque. A boost function is included to prevent torque trip during initial valve unseating and extreme arctic temperature operation (from 0°C down to -60°C [32°F down to -76°F]).

### Exterior corrosion protection

As standard, the MXb actuator is coated with a polymer powder coat suitable for exposure to an ASTM B117 salt spray test of 2,000 hours. External fasteners are 300 series stainless steel. Optional coatings are available by contacting the factory.

### Manual operation

A handwheel and declutch lever are provided for manual operation. The handwheel is metal, and changing from motor to manual operation is accomplished by engaging the declutch lever. Energizing the motor returns the MXb actuator to motor operation. The lever is padlockable in either motor or manual operation. Optional configurations for handwheels are available by consulting the factory.

### Factory testing

Every MXb actuator is factory-tested to verify rated output torque, output speed, handwheel operation, local control, control power supply, valve jammed function, all customer inputs and outputs, motor current, motor thermistor, LCD and LED operations, direction of rotation, microprocessor checks and position-sensor checks. A report confirming successful completion of testing is included with the actuator. Special testing can also be performed by contacting the factory.

### Design life and endurance testing

- Design life – One million drive sleeve turns is considered typical life expectancy under normal operating conditions and approved ambient working environments.
- Endurance – 50 million collective drive sleeve turns of endurance testing were performed on the MXb actuator for proof of design.
- AWWA C540-02 – “Standard for Power Actuating Devices for Valves and Sluice Gates” – 10,000 cycles with confirmation of specified torque and position accuracy





## Optional features

### Analog position transmitter

A non-contacting, internally powered, electrically isolated position transmitter can be included to provide a 4-20 mA or 0 to 10 VDC signal that is proportional to valve position.

### Analog torque transmitter

A non-contacting, internally powered, electrically isolated torque transmitter can be included to provide a 4-20 mA or 0 to 10 VDC signal that is proportional to rated output torque.

Voltages or Currents for APT/ATT	Maximum/Minimum External Load—APT/ATT
4-20 mA	470 ohms—99.9% accuracy 750 ohms for 99% accuracy
0 to 10 VDC	1,000 ohms minimum—99.9% accuracy 2,700 ohms minimum—99% accuracy

### Modutronic option

A controller that alters valve position in proportion to a 4-20 mA analog command signal can be ordered. Positioning is accomplished by comparing the command signal to a noncontacting internal position feedback. An automatic pulsing feature to prevent overshoot at the setpoint is included. Proportional bands, deadband, signal polarity, motion inhibits time and fail are adjustable using the Local control mode of configuration. Deadband is adjustable to +/- 0.5% full span.

Voltages or Currents for Modulation	Input Impedance/Capacitance
4-20 mA	470 ohms—99.9% accuracy 750 ohms for 99% accuracy
0 to 10 VDC	1,000 ohms minimum—99.9% accuracy 2,700 ohms minimum—99% accuracy

### Relays for status and alarms

Up to four additional latching output contacts rated 250 VAC/30 VDC, 5 A and configurable to represent any actuator status in either N/O or N/C state are available. Please refer to "Status and Alarm Contacts for Remote Indication" for list of settings.

"R" Contact and AC Ratings	"R" Contact and DC Ratings
5.0 Amps @ 250 VAC	5A @ 30 VDC (resistive)

## Global certifications

Non-hazardous (weatherproof / submersion) certifications IEC 529 protection code IP68; 15 meters for 96 hours USA; NEMA 3, 4, NEMA 4X, NEMA 6

Geographic Locations	Weatherproof/Submersion	Standard Temperature
IEC 529 Protection Code IP68	15M for 96 hours	-30°C to 65°C (-22°F to 149°F)
USA & Canada, NEMA 3, 4, 6	20 ft for 24 hours	-30°C to 70°C (-22°F to 156°F)
USA & Canada, NEMA 4X	1,500 hrs. to ASTM B117	-30°C to 70°C (-22°F to 156°F)

### Standard hazardous global certifications

- FM – Class I, Groups B, C & D, Div. 1 & Class II, Groups E, F & G, T4
- ATEX EExd IIB T4 ATEX II 2 G, CENELEC Norm EN 60079-0:2006 and EN 60079-1:2004
- ATEX EExd IIC T4 ATEX II 2 G, CENELEC Norm EN60079-1:2004
- EEx de IIB T4 ATEX II G, Increased Safety, CENELEC Norm EN 60079-7:2003
- ATEX EEx de II C T4
- IECEx d IIC, T4, Gb, X from -20°C to 60°C (-4°F to 140°F)
- IECEx de IIB/IIC, T4, Gb, X from -20°C to 60°C (-4°F to 140°F)
- IECEx d IIB (or IIC) T4 -20°C (-4°F) ≤ Tamb ≤ +60°C; IP68 - Size 05, 10, 20, 40, 85, 140 or 150
- IECEx de IIB (or IIC) T4 -20°C (-4°F) ≤ Tamb ≤ +60°C; IP68 - Size 05, 10, 20, 40, 85, 140 or 150. Group IIC design also available and requires special construction. Contact factory Inmetro - same as IECEx, except that -60°C (-76°F) is N/A.

Geographic Locations	Explosion-proof Classifications	Standard Temperature
USA to Factory Mutual (FM)	Class I, Groups B, C, & D, Div. 1, T4 and Class II, Groups E, F, & G, Div. 2, T4	-30°C to 65°C (-22°F to 149°F)
ATEX II 2 G, CENELEC Norm EN 50014 & 50018	EEx d IIB T4, EEx d IIC T4, and EEx de IIB T4, EEx de IIC T4	-30°C to 65°C (-22°F to 149°F)
IECEx	Ex d IIB T4; IP68 & Ex d IIB (or IIC) T4; IP68 & Ex de IIB (or IIC) T4	-20°C to 60°C (-4°F to 140°F)

Note: Options are available to -60°C (-74°F) for TR-CU (Russia). Consult factory for availability. \*Consult factory for limitations.

### European directives

All MXb actuator designs have been tested to comply with pertinent EU Directives and shipped with the Declaration of Conformity listed in the Regulatory Section of VAIOM000071. The actuator is also tagged with the CE mark to demonstrate compatibility with the following European Directives:

All MXb actuator designs have been tested to demonstrate compatibility with the following European directives and are marked with the CE label:

- 2006/42/EC – Machinery Directive
- Vibration and seismic capability is in accordance with MILSTD-167, IEEE-344-1975 and IEC88-2-6. Test performed in each of three (3) axes, H1, horizontal – parallel to motor, H2, horizontal – perpendicular to motor, and "V1," vertical

Vibration Levels (MX actuator functions after event)	Seismic Levels (MX actuator functions after event)
5 to 100 Hz sine sweeps, 0.75g 3 axes	2 Hz 2g, 2.5 to 35 Hz 3g, sine dwell, 3 axes
5 to 500 Hz sine sweeps, 1.0g 3 axes	1 Hz 0.5g, 2 to 50 Hz 1g, sine sweeps, 3 axes
25 Hz 2g, 40 to 200 Hz 3g, sine dwells, 3 axes	

- 2006/42/EC – Airborne Noise to EN 60204-1. The MX0 actuator has been tested for noise emissions and at 1 m (3.3 ft) distance is less than 74 dB per grade A noise requirement of MIL-STD-740 and ANSI/ISA-S82.01-1994 (harmonized std. to IEC 1010-1).
- 2014/30/EU -EMC - Electromagnetic Compatibility and 2014/35/EU Low Voltage; EN 50081-1 & 2 – Three-phase ACV actuator complies with all pertinent requirements of Class A service categories in the listed table.

Three-phase ACV actuators comply with all pertinent requirements of Class A service categories in the listed table:

Applicable Emissions Standards	EN61326-1 (CISPR11)	Industrial Environments - Class A - Test Limits & Levels	
Radiated Emissions	EN55011:2009+A1:2010 (CISPR11)	30 MHz to 230 MHz 230 MHz to 1 GHz	40 dB (µV/m) 47 dB (µV/m)
	FCC Part 15, (CFR47 Part 15.109)	30 MHz to 88 MHz 88 MHz to 216 MHz 216 MHz to 960 MHz > 960 MHz	90 dB (µV/m) 150 dB (µV/m) 210 dB (µV/m) 300 dB (µV/m)
Conducted Emissions	EN55011:2009+A1:2010 (CISPR11)	150 kHz to 500 kHz 500 kHz to 30 MHz	79 dB (µV) (quasi-pk), 68 dB (µV) (avg)
	FCC Part 15, (CFR47 Part 15.107)		73 dB (µV) (quasi-pk), 60 dB (µV) (avg)
Applicable Immunity Standards		Industrial Environments - Test Limits & Levels	
ESD	IEC61000-4-2 (B)	Air: AC, DC, Signal	±2 kV, ±4 kV, ±8 kV
		Contact: AC, DC, Signal	±1 kV, ±2 kV, ±4 kV
Radiated RF Immunity	IEC61000-4-3 (A)	Enclosure @ 90 MHz to 1 GHz	10 Vrms/m @ 80% AM, 1 kHz
		Enclosure @ 1 GHz to 2.7 GHz	3 Vrms/m @ 80% AM, 1 kHz
Fast Transients/Burst	IEC61000-4-4 (B)	AC, Signal	±2 kV, ±1 kV
Voltage Surges	IEC61000-4-5 (B)	Common: AC, Signal Differential: AC, Signal	±2 kV, ±1 kV ±1 kV, ±1 kV
Conducted RF Immunity	IEC61000-4-6 (A)	AC @ 150 kHz to 80 MHz	10 Vrms @ 80% AM, 1 kHz
Magnetic Field Immunity	IEC61000-4-8 (A)	Three mounting axis	30 A/m
Voltage Dips and Interrupts	IEC61000-4-11 (B)	3 dips, 10 sec apart	> 95% dip for 1 cycle @ 50/60 Hz 30% dip for 500 ms @ 50/60 Hz 60% dip for 200 ms @ 50/60 Hz
	IEC61000-4-11 (C)	3 dips, 10 sec apart	> 95% interrupt for 5 sec @ 50/60 Hz

### Conduit entries

Three threaded conduit entries are provided tapped: 1 x 1½ in and 2 x 1¼ in NPT. Unless otherwise specified, actuator will be dispatched with adapters: 1 x M40 and 2 x M32 metric to BS3643; PG adapters are available upon request. An optional, fourth conduit, tapped to 1.0 in NPT or 25 mm, is available.

- Di-electric – Motor per NEMA MG1-12.02 and 0.03 with leakage of less than 10 mA. Control terminals per IEC-1131-2 with check against physical breakdown.