

INSTALL PROTECTIVE REBAR COATING. REFERENCE DETAIL #606 FOR TYPICAL REQUIREMENTS

NEW CONCRETE REBUILD MATERIAL

FINISHED SURFACE

INSTALL DISCRETE GALVANIC ANODES AT REBUILD PERIMETER OR AS OTHERWISE SPECIFIED. REFERENCE DETAIL #605 FOR TYPICAL ANODE LAYOUT

SEE DETAIL #604 FOR ENLARGEMENT SECTION

EXCAVATE AS REQUIRED TO OBTAIN MINIMUM CLEAR COVER

1" MIN. CLEAR

EXISTING CONCRETE TO REMAIN

CONDUCTIVE EMBEDDED MORTAR AS REQUIRED. REFERENCE SECTION XX FOR TYPICAL REQUIREMENTS

1" MIN. CLEAR

EXCAVATE AS REQUIRED TO OBTAIN MINIMUM CLEAR COVER

2" MIN.

NOTES:

1. REFERENCE SPECIFICATION 03700 FOR CONCRETE REBUILD INFORMATION NOT OTHERWISE SHOWN.
2. GALVANIC ANODE SIZES AND SHAPES MAY VARY.

NOT TO SCALE

	STANDARD DESIGN DETAIL	DRAWING NO. 600
	INSTALLATION OF DISCRETE GALVANIC ANODES	SHEET 1 OF 1
		DATE 2/2024

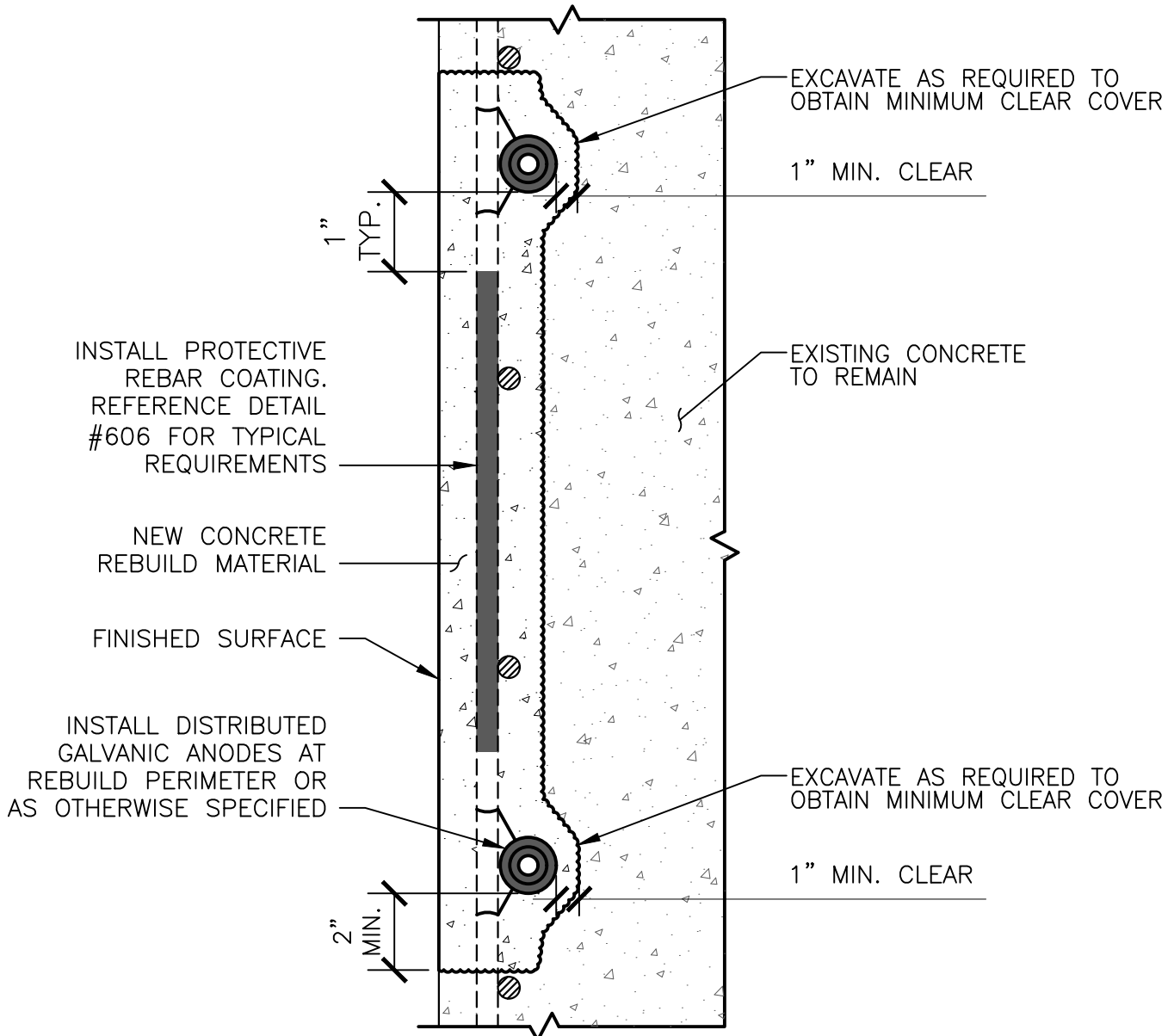

INSTALL PROTECTIVE REBAR COATING. REFERENCE DETAIL #606 FOR TYPICAL REQUIREMENTS

NEW CONCRETE REBUILD MATERIAL

FINISHED SURFACE

INSTALL DISTRIBUTED GALVANIC ANODES AT REBUILD PERIMETER OR AS OTHERWISE SPECIFIED

EXCAVATE AS REQUIRED TO OBTAIN MINIMUM CLEAR COVER

1" MIN. CLEAR

EXISTING CONCRETE TO REMAIN

EXCAVATE AS REQUIRED TO OBTAIN MINIMUM CLEAR COVER

1" MIN. CLEAR

1" TYP.

2" MIN.

NOTES:

1. REFERENCE SPECIFICATION 03700 FOR CONCRETE REBUILD INFORMATION NOT OTHERWISE SHOWN.
2. CONDUCTIVE MORTAR NOT SHOWN. ENCAPSULATE ANODES IN CONDUCTIVE MORTAR AS REQUIRED BY MANUFACTURER.
3. GALVANIC ANODE SIZES AND SHAPES MAY VARY.

NOT TO SCALE

	STANDARD DESIGN DETAIL	DRAWING NO. 601
	INSTALLATION OF DISTRIBUTED GALVANIC ANODES	SHEET 1 OF 1
		DATE 2/2024

INSTALL DISTRIBUTED GALVANIC ANODES AT REBUILD PERIMETER OR AS OTHERWISE SPECIFIED

TOP OF WALL

INSTALL PROTECTIVE REBAR COATING. REFERENCE DETAIL #606 FOR TYPICAL REQUIREMENTS

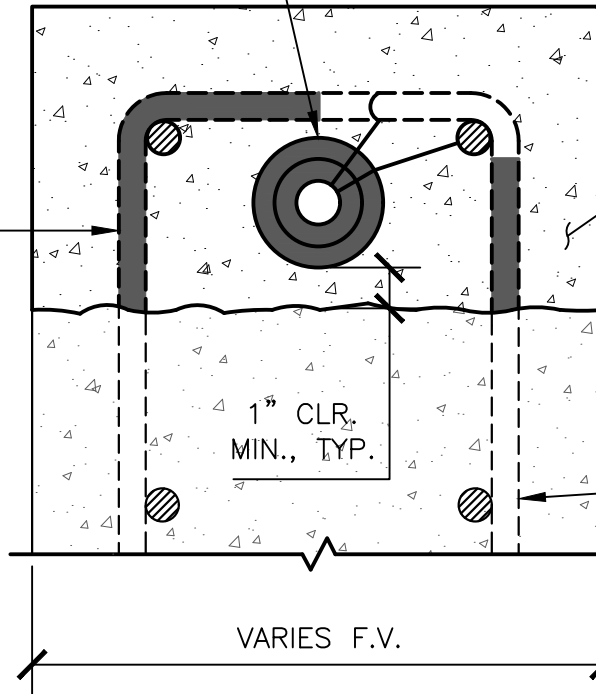

NEW CONCRETE REBUILD MATERIAL

EXISTING CONCRETE WALL AND REINFORCEMENT

1" CLR. MIN., TYP.

VARIES F.V.

NOTES:

1. REFERENCE SPECIFICATION 03700 FOR CONCRETE REBUILD INFORMATION NOT OTHERWISE SHOWN.
2. CONDUCTIVE MORTAR NOT SHOWN. ENCAPSULATE ANODES IN CONDUCTIVE MORTAR AS REQUIRED BY MANUFACTURER.
3. GALVANIC ANODE SIZES AND SHAPES MAY VARY.

NOT TO SCALE



STANDARD DESIGN DETAIL

DISTRIBUTED GALVANIC ANODES
AT TOP OF WALL

DRAWING NO.

602

SHEET

1 OF 1

DATE

2/2024

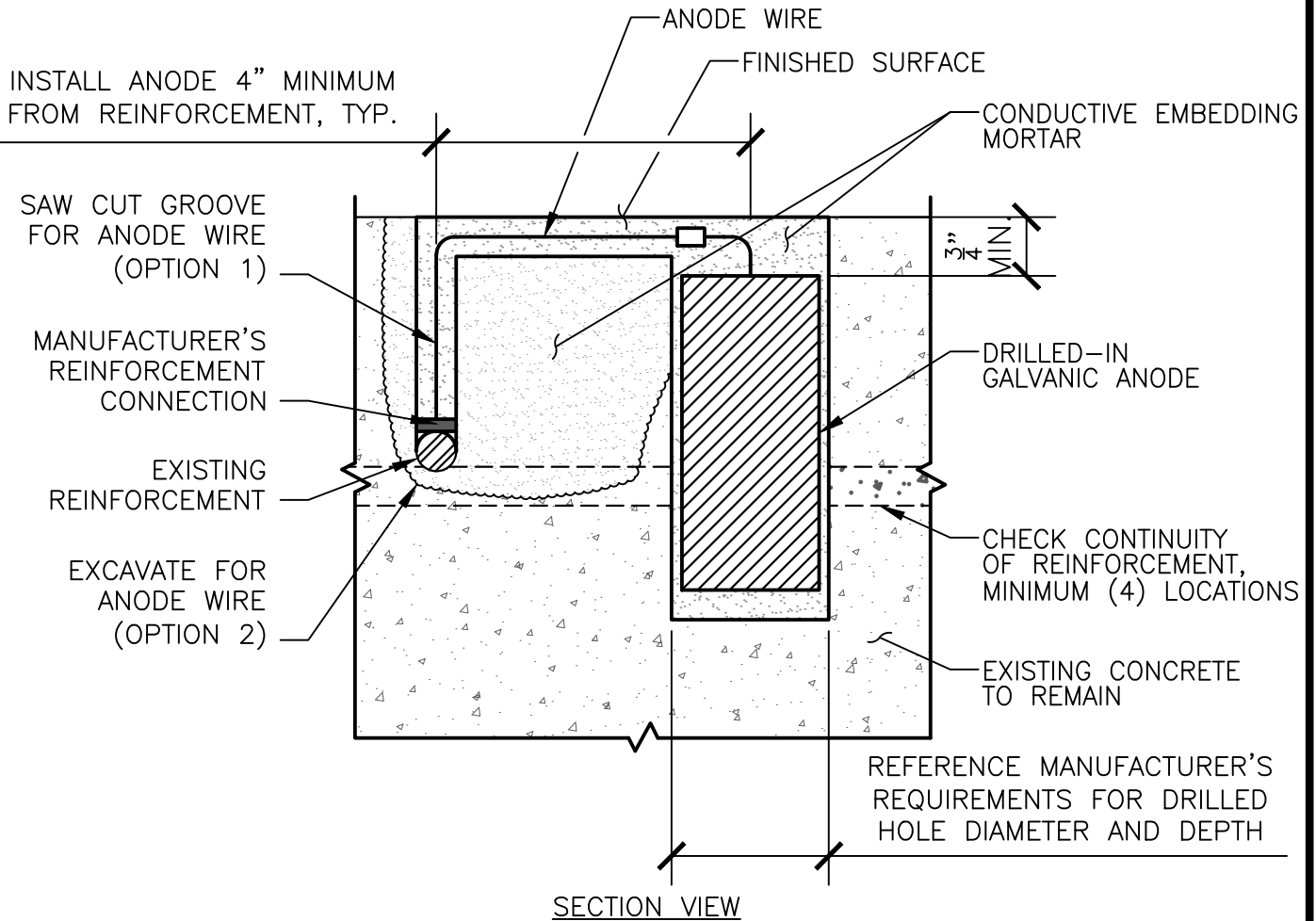
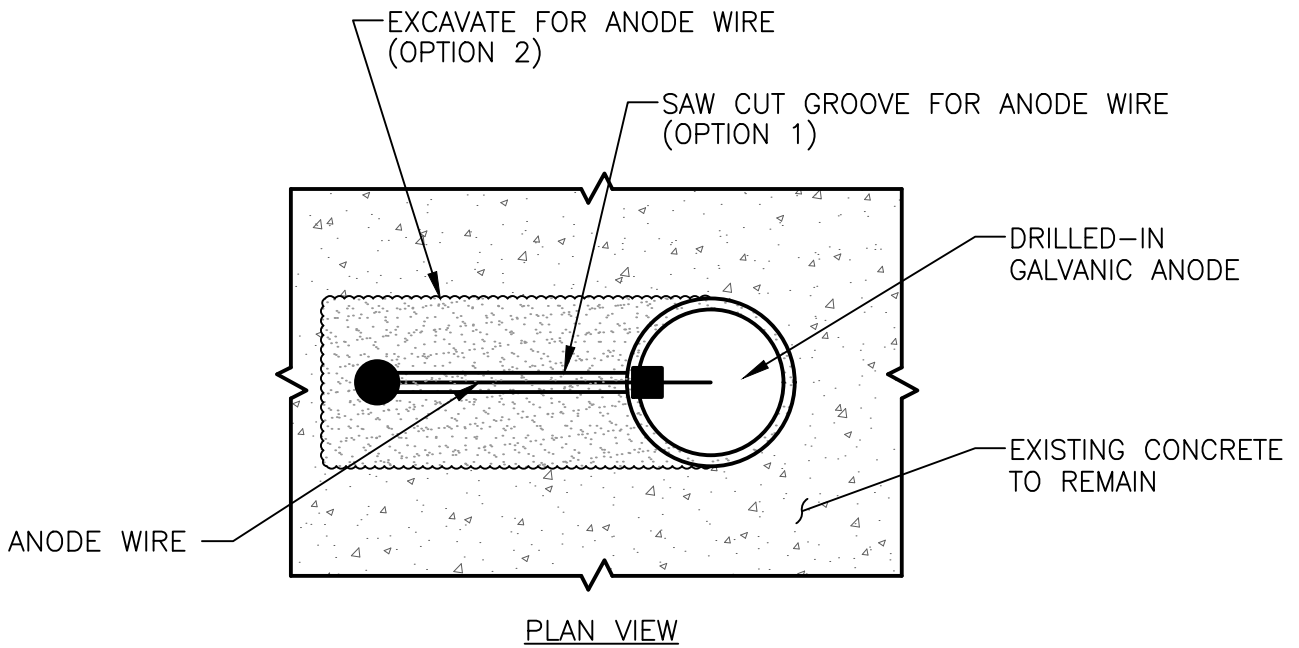

NOT TO SCALE



STANDARD DESIGN DETAIL

INSTALLATION OF
DRILLED-IN GALVANIC ANODES

DRAWING NO.

603

SHEET

1 OF 1

DATE

2/2024

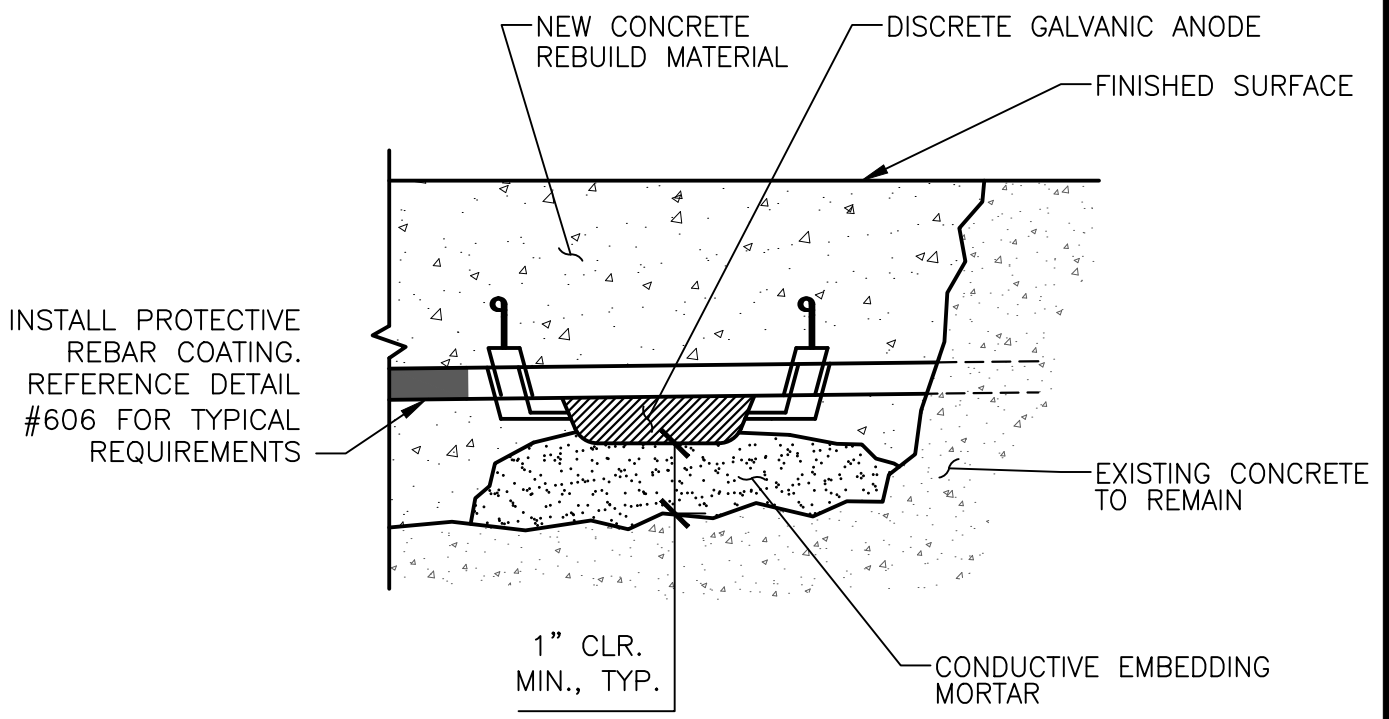

NOTES:

1. CONDUCTIVE BEDDED MORTAR SHALL BE INSTALLED FOR ANODES WHEN NEW CONCRETE REBUILD MATERIAL ELECTRICAL RESISTIVITY IS GREATER THAN 15,000 OHM-CM.
2. GALVANIC ANODE SIZES AND SHAPES MAY VARY.

NOT TO SCALE

	STANDARD DESIGN DETAIL	DRAWING NO. 604
	CONDUCTIVE MORTAR BRIDGE FOR USE WITH HIGH RESISTIVITY REPAIR MORTARS	SHEET 1 OF 1
		DATE 2/2024

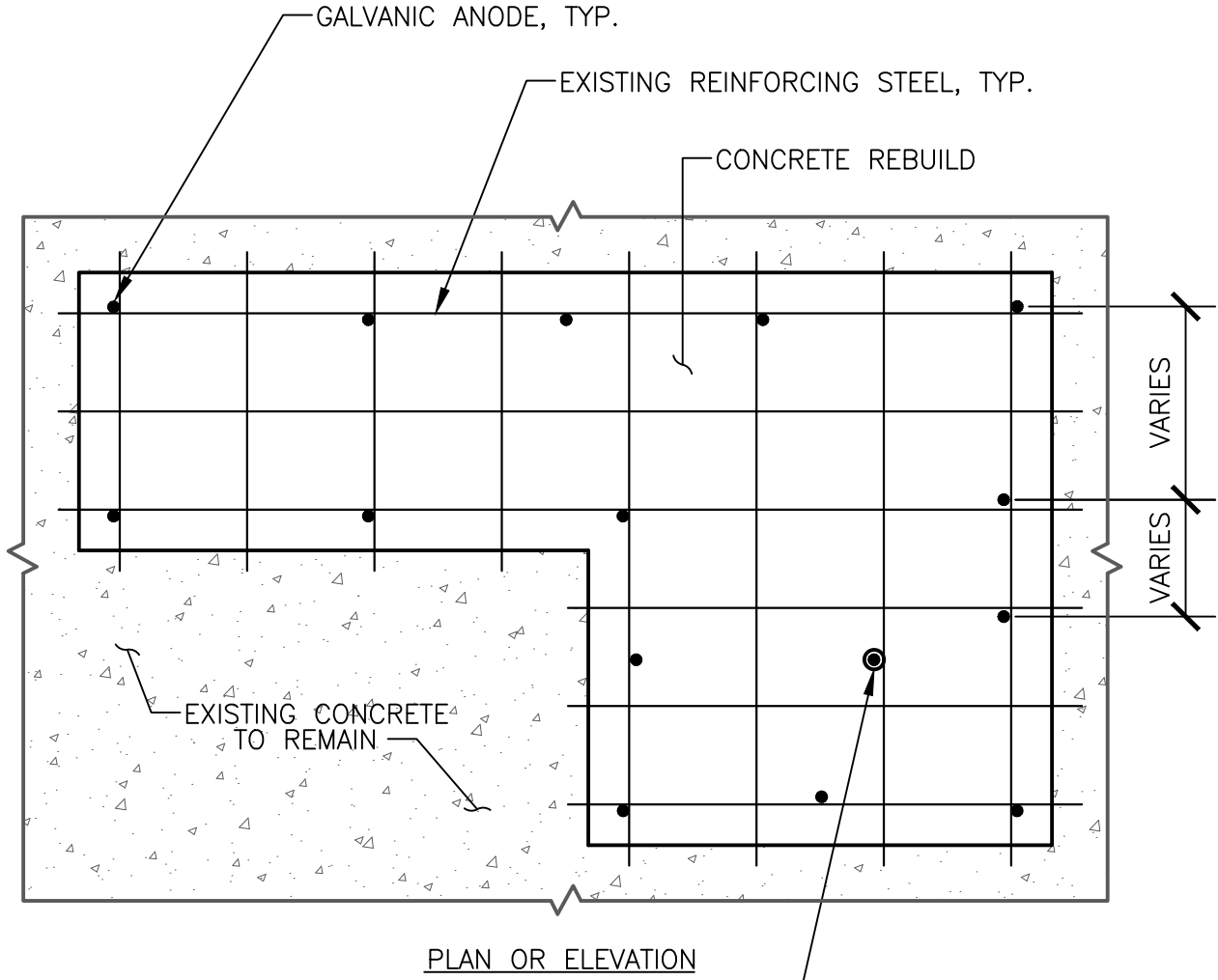

GALVANIC ANODE AT REINFORCEMENT PENETRATIONS, AS REQUIRED.

NOTES:

1. REFERENCE SPECIFICATION 03700 FOR CONCRETE REBUILD INFORMATION NOT OTHERWISE SHOWN.
2. GALVANIC ANODE SPACING SHALL BE IN ACCORDANCE WITH SPECIFICATION REQUIREMENTS.
3. SEE DETAIL #606 FOR TYPICAL ANODE CONNECTION DETAILS.

NOT TO SCALE



STANDARD DESIGN DETAIL

TYPICAL GALVANIC ANODE LAYOUT

DRAWING NO.

605

SHEET

1 OF 1

DATE

2/2024

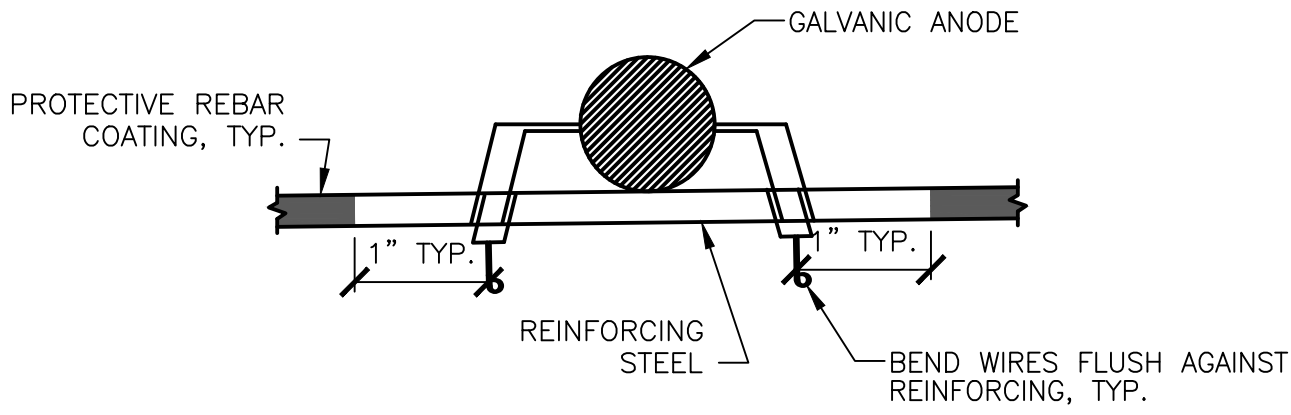

TYPICAL INSTALLATION TO SIDE REBAR

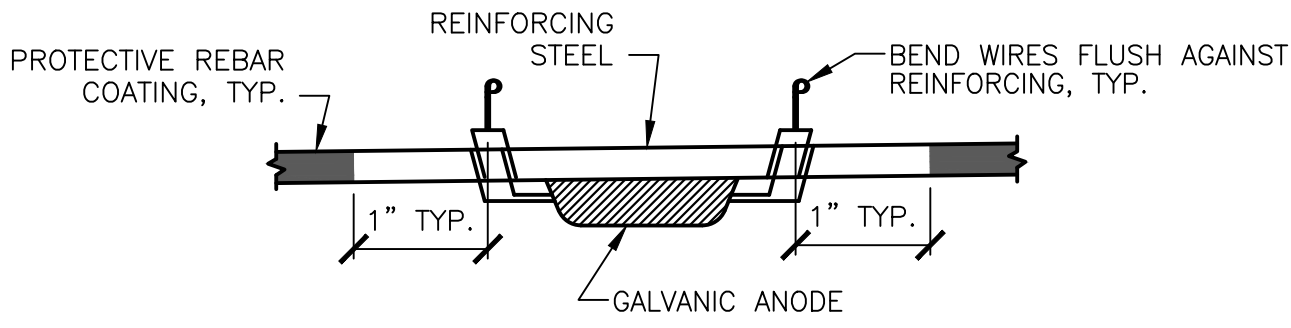

TYPICAL INSTALLATION ABOVE/BELOW REBAR

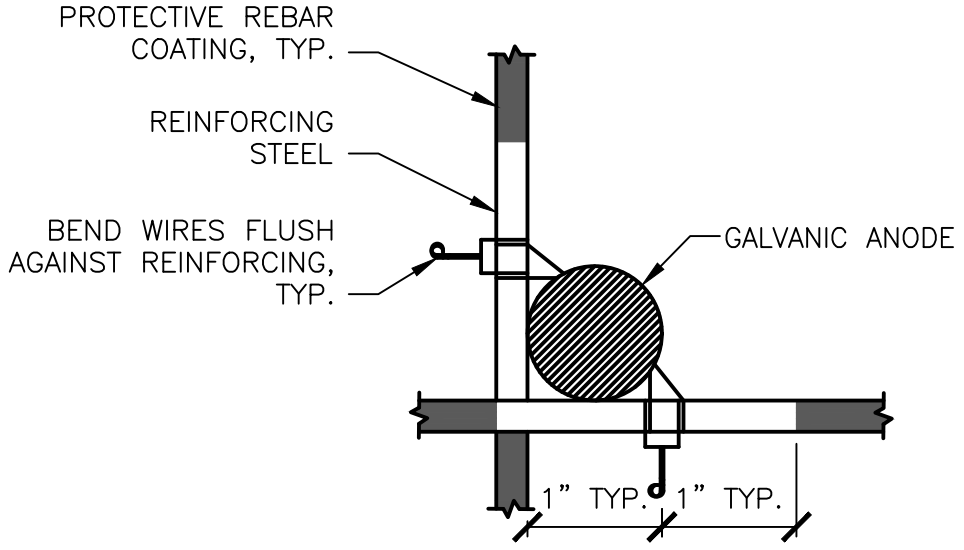

TYPICAL INSTALLATION AT REBAR INTERSECTION

NOTES:
 1. GALVANIC ANODE SIZES AND SHAPES MAY VARY.

NOT TO SCALE

	STANDARD DESIGN DETAIL	DRAWING NO. 606
	TYPICAL GALVANIC ANODE CONNECTIONS	SHEET 1 OF 1
		DATE 2/2024

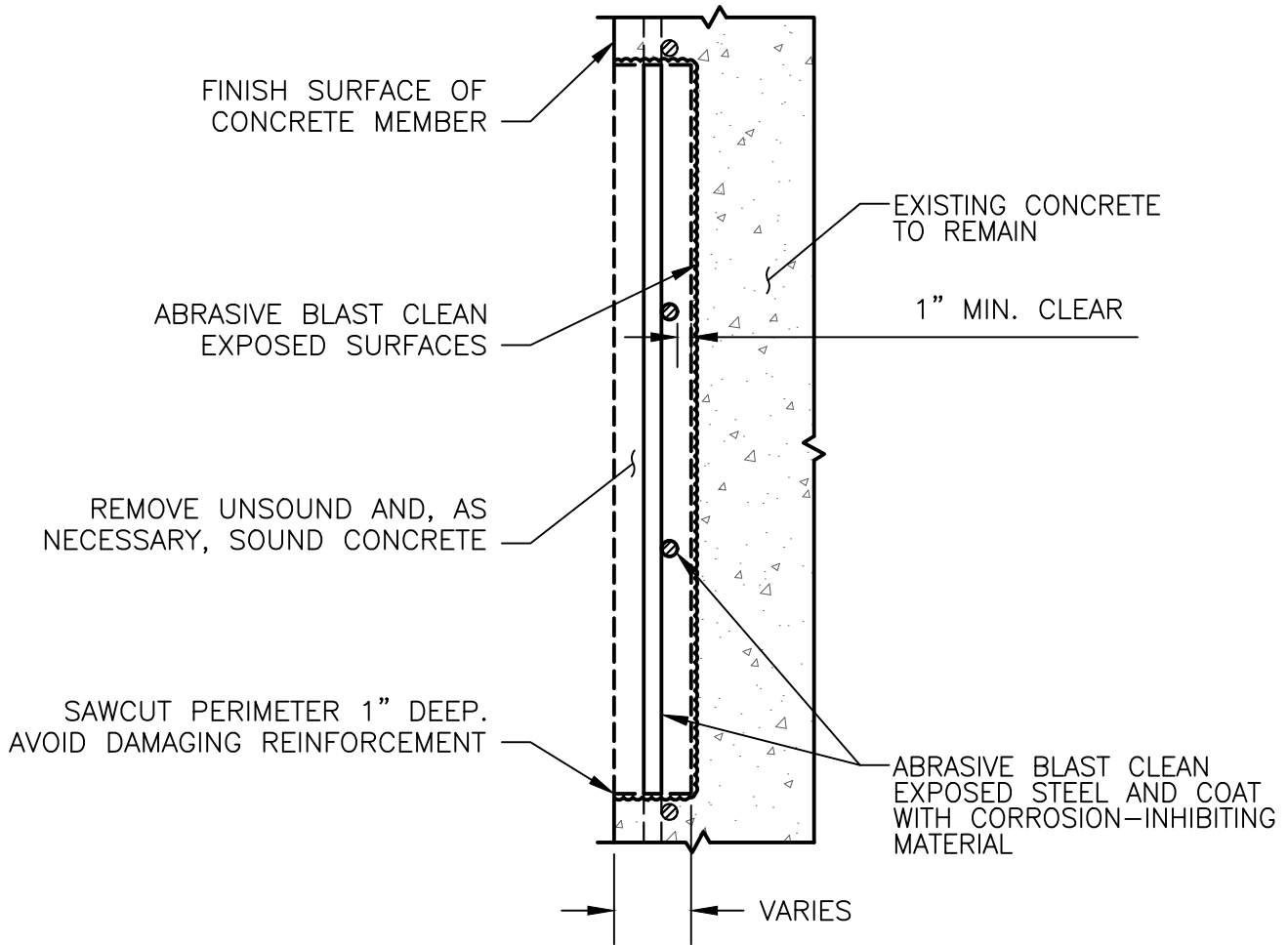

NOT TO SCALE

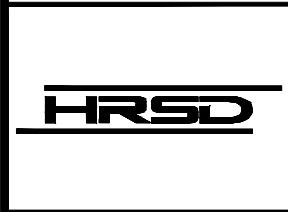

STANDARD DESIGN DETAIL

REMOVAL OF UNSOUND CONCRETE
TYPICAL SECTION

DRAWING NO.	626
SHEET	1 OF 1
DATE	2/2024

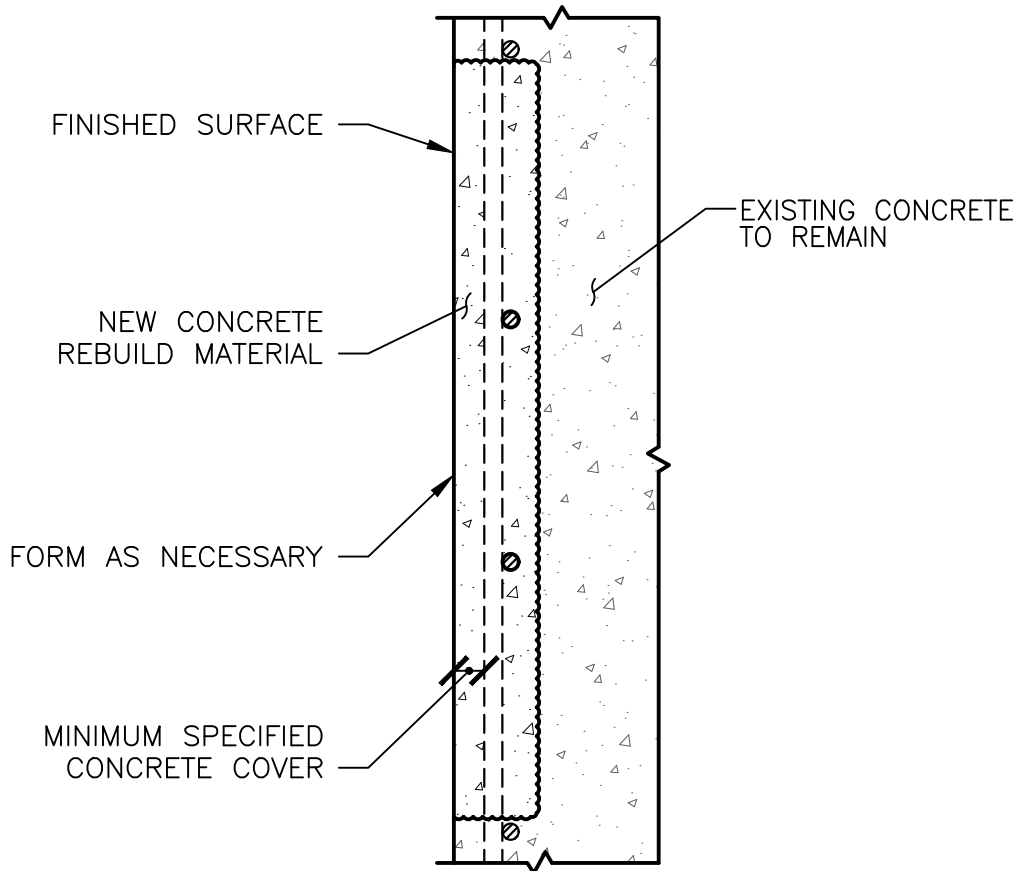

NOTES:

1. GALVANIC ANODES NOT SHOWN FOR CLARITY. REFER TO SPECIFICATION 03800 FOR REQUIREMENTS.

NOT TO SCALE

	STANDARD DESIGN DETAIL	DRAWING NO. 627
	CONCRETE REBUILD TYPICAL SECTION	SHEET 1 OF 1
		DATE 2/2024

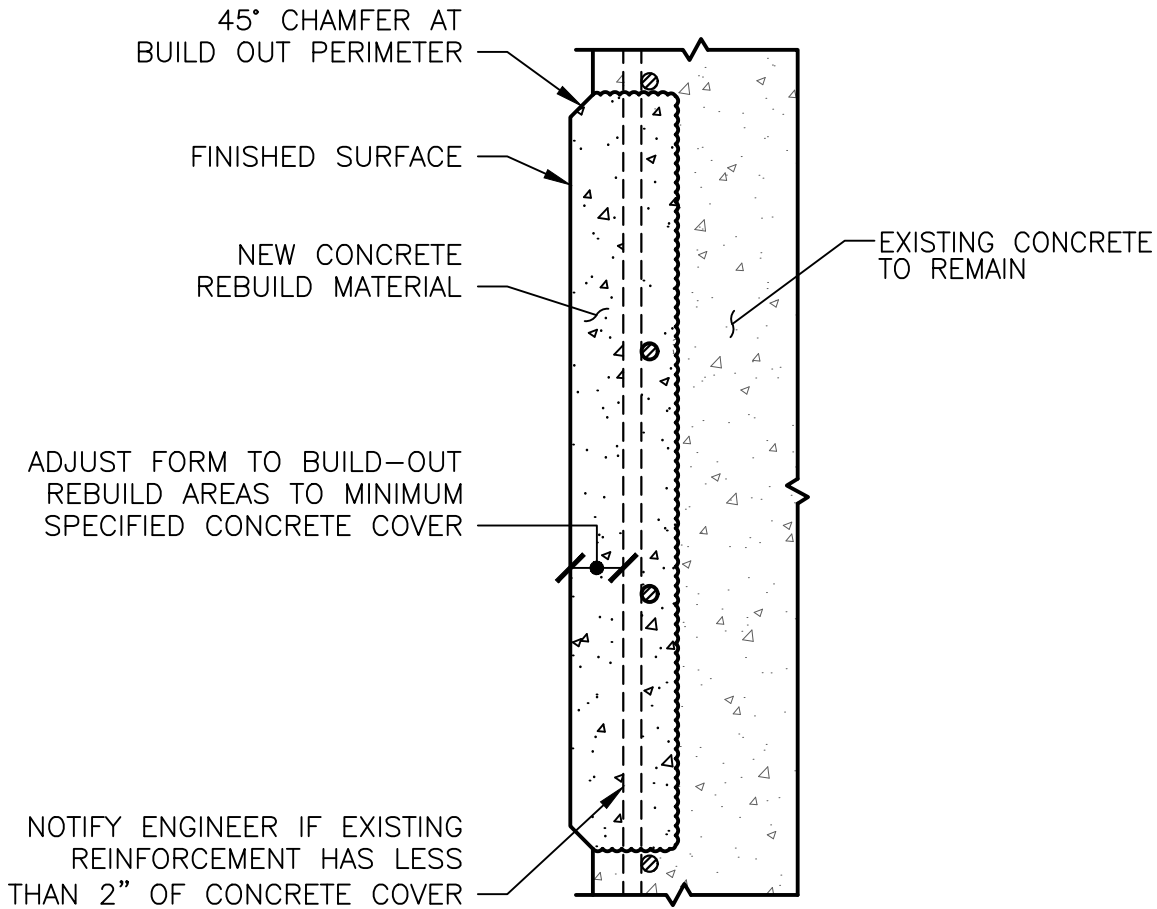

NOTES:

1. GALVANIC ANODES NOT SHOWN FOR CLARITY. REFER TO SPECIFICATION 03800 FOR REQUIREMENTS.

NOT TO SCALE

	STANDARD DESIGN DETAIL	DRAWING NO. 628
	MINIMUM COVER CONCRETE REBUILD	SHEET 1 OF 1
		DATE 2/2024

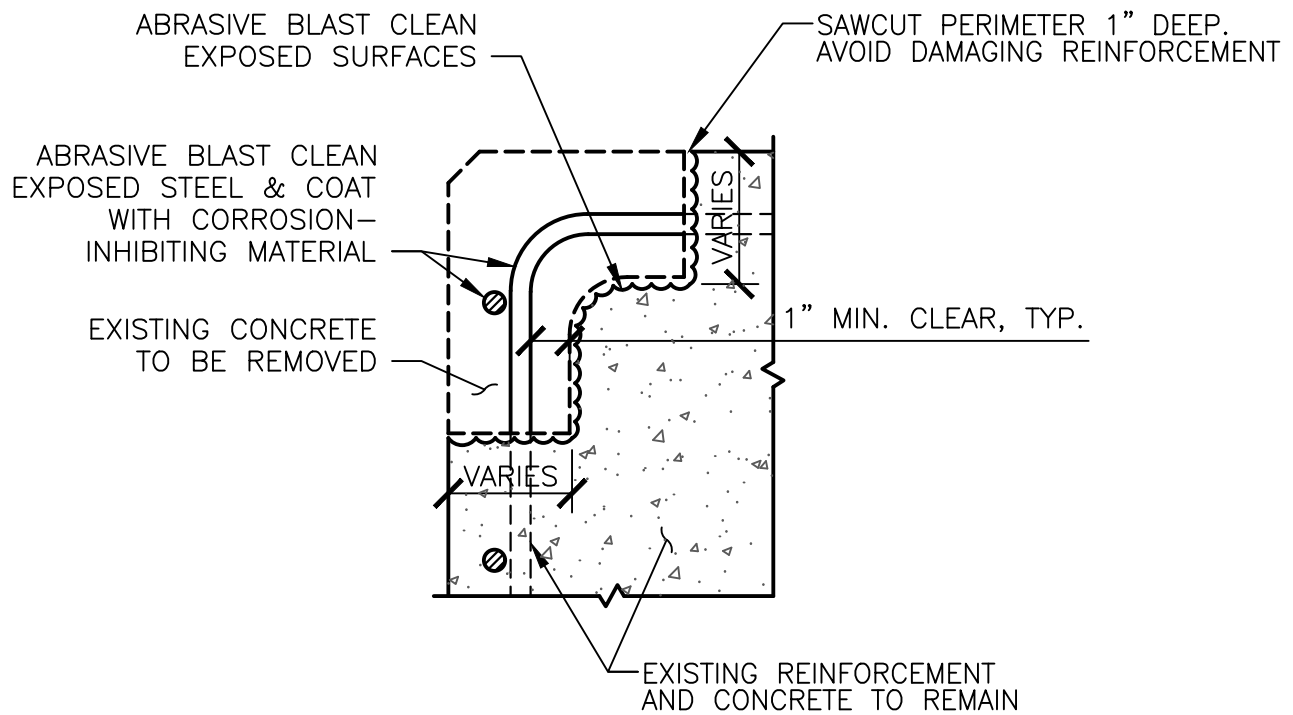

NOTES:

1. GALVANIC ANODES NOT SHOWN FOR CLARITY. REFER TO SPECIFICATION 03800 FOR REQUIREMENTS.

NOT TO SCALE

	STANDARD DESIGN DETAIL	DRAWING NO. 629
	REMOVAL OF UNSOUND CONCRETE CORNER SECTION	SHEET 1 OF 1
		DATE 2/2024

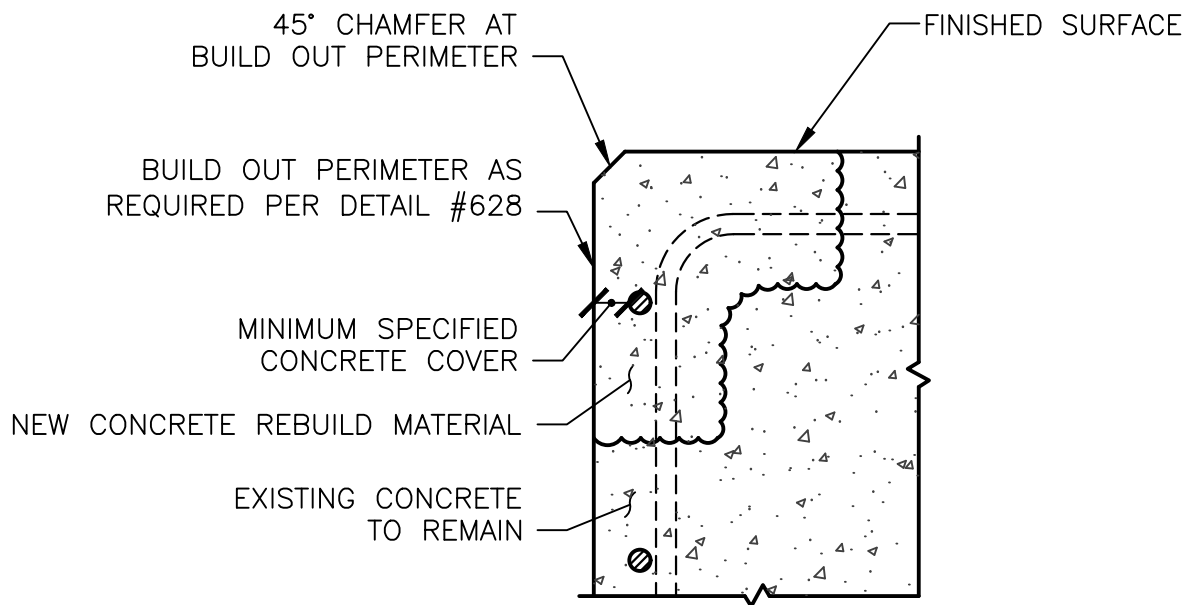

NOTES:

1. GALVANIC ANODES NOT SHOWN FOR CLARITY. REFER TO SPECIFICATION 03800 FOR REQUIREMENTS.

NOT TO SCALE

	STANDARD DESIGN DETAIL	DRAWING NO. 630
	CONCRETE REBUILD CORNER SECTION	SHEET 1 OF 1
		DATE 2/2024

10% SECTION LOSS

BAR NO.	DIAMETER IN.	AREA IN. ²	BAR DIAMETER WITH 10% SECTION LOSS (IN.)	
			CIRCUMFERENTIAL LOSS	ONE – SIDED LOSS
3	0.375	0.110	0.356	0.315
4	0.500	0.196	0.474	0.420
5	0.625	0.307	0.593	0.525
6	0.750	0.442	0.712	0.625
7	0.875	0.601	0.830	0.735
8	1.000	0.785	0.949	0.835
9	1.128	0.999	1.070	0.945
10	1.270	1.267	1.205	1.060
11	1.410	1.561	1.338	1.180



CIRCUMFERENTIAL LOSS

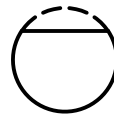

ONE – SIDED LOSS



STANDARD DESIGN DETAIL

REINFORCING SECTION LOSS TABLE

DRAWING NO.

631

SHEET

1 OF 1

DATE

2/2024

SUPPLEMENTAL REINFORCING
BAR TO MATCH EXISTING

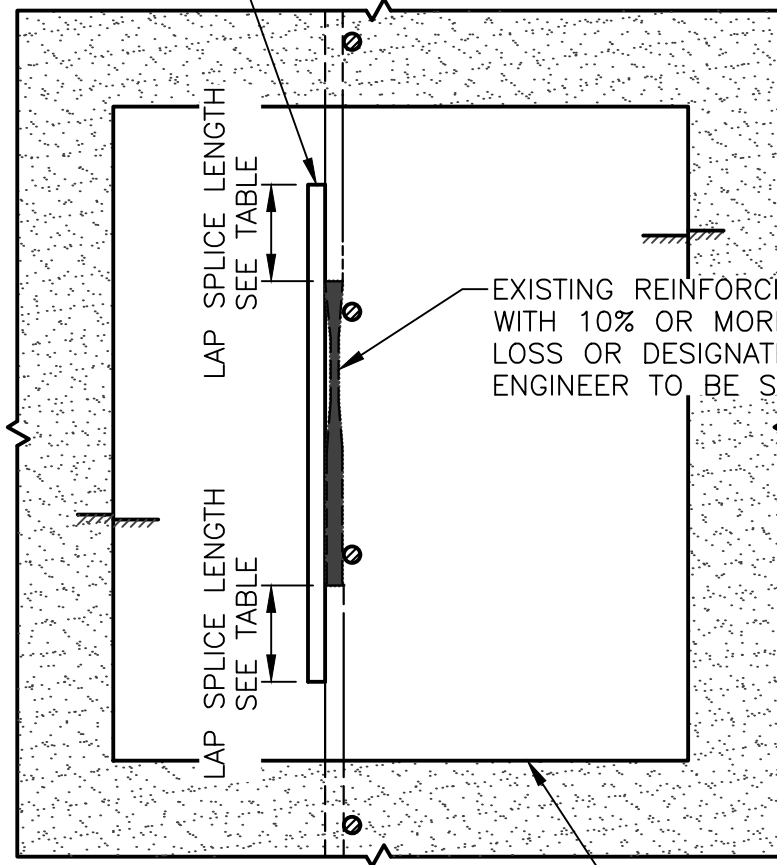

PLAN OR ELEVATION

EXTENT OF CONCRETE
REMOVAL AREA

NOT TO SCALE



STANDARD DESIGN DETAIL

LAP SPLICE - OPTION 1

DRAWING NO.

632

SHEET

1 OF 1

DATE

2/2024

TENSION LAP LENGTH – CLASS B SPLICE – TOP & BOTTOM BARS
(GRADE 60 UNCOATED BARS & NORMAL WEIGHT CONCRETE)

BAR NO.	f _c =4,000PSI		f _c =5,000PSI	
	TOP	BOT	TOP	BOT
3	15"	12"	13"	12"
4	20"	15"	18"	14"
5	24"	19"	22"	17"
6	29"	22"	26"	20"
7	42"	33"	38"	29"
8	48"	37"	43"	33"
9	60"	46"	54"	41"
10	74"	57"	66"	51"
11	89"	68"	79"	61"

NOTES:

1. THIS TABLE IS BASED ON ACI 318-11, EQUATION 12-1 WITH A MINIMUM CLEAR COVER OF 2 INCHES AND MINIMUM CENTER-TO-CENTER BAR SPACING OF 5 INCHES.
2. "TOP" BARS ARE HORIZONTAL REINFORCING BARS WITH MORE THAN 12 INCHES OF FRESH CONCRETE CAST BELOW THE BARS AT THE DEVELOPMENT LENGTH. ALL OTHER BARS ARE CONSIDERED "BOT" BARS.
3. FOR EPOXY COATED OR ZINC AND EPOXY DUAL COATED BARS, MULTIPLY THE TABLE VALUES BY 1.5 FOR BOTTOM BARS, OR 1.3 FOR TOP BARS. IF THE CONCRETE COVER IS AT LEAST 3X THE BAR DIAMETER AND CLEAR SPACING AT LEAST 6X THE BAR DIAMETER, MULTIPLY VALUES BY 1.2.
4. FOR CLASS A SPLICE, DIVIDE VALUES BY 1.3.
5. FOR LIGHTWEIGHT CONCRETE, MULTIPLY VALUES BY 1.33.

	STANDARD DESIGN DETAIL	DRAWING NO. 633
		SHEET 1 OF 1
	LAP SPLICE LENGTHS – OPTION 1	DATE 2/2024

3" MINIMUM BEYOND
SECTION LOSS AND/OR
CORROSION, TYP.

REINFORCING BAR
REMOVAL LENGTH

FINISHED SURFACE

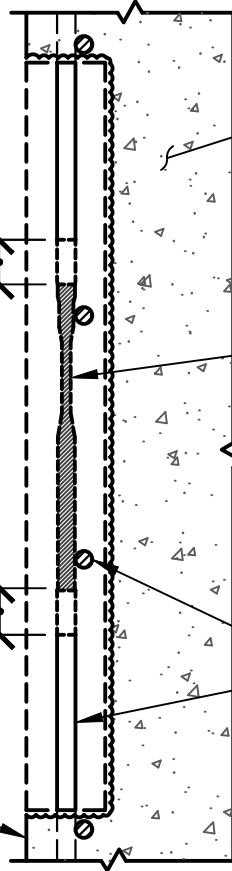

EXISTING CONCRETE
TO REMAIN

EXISTING REINFORCING
BAR WITH 10% OR MORE
SECTION LOSS OR
DESIGNATED BY ENGINEER
TO BE SUPPLEMENTED

EXISTING REINFORCING
TO REMAIN

NOT TO SCALE

HRSD

STANDARD DESIGN DETAIL

MECHANICAL SPLICE – OPTION 2
TYPICAL REMOVAL SECTION

DRAWING NO.

634

SHEET

1 OF 1

DATE

2/2024

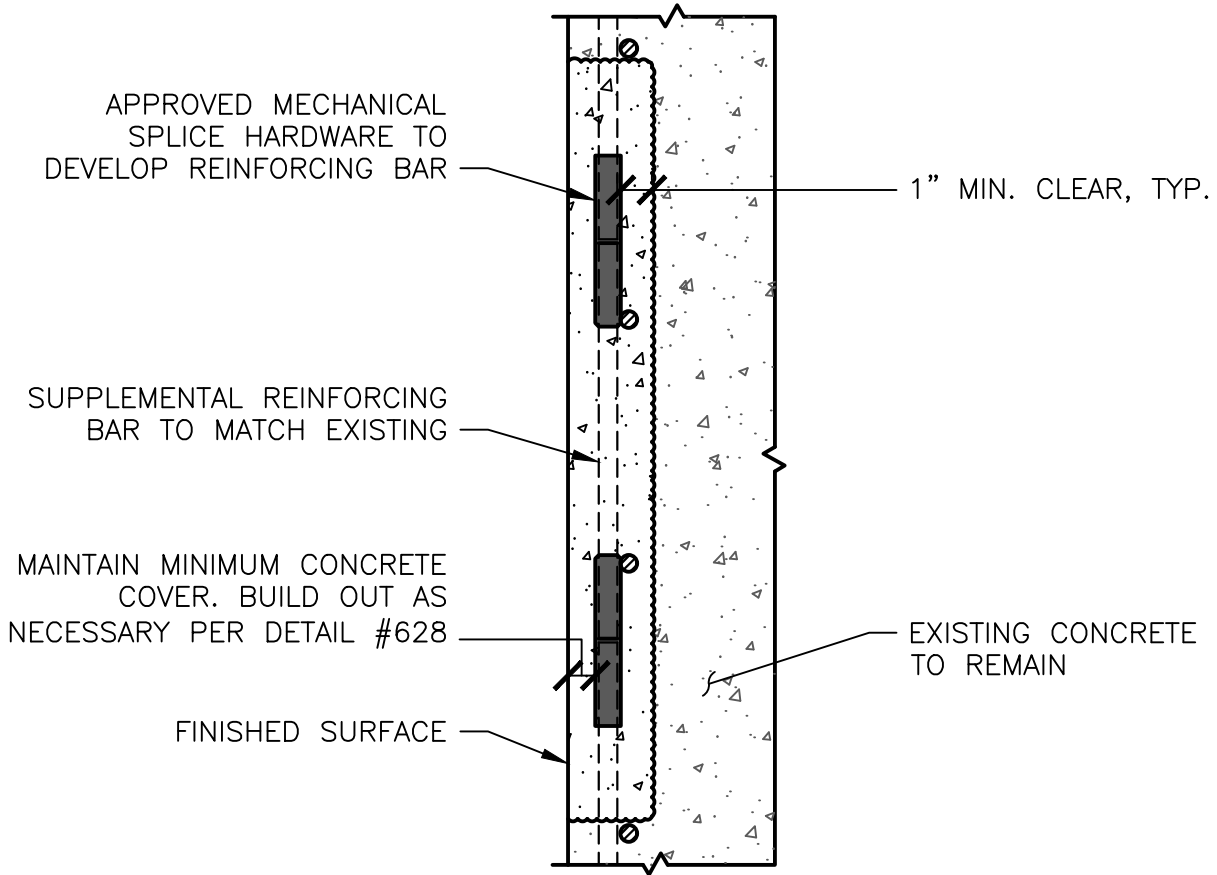

NOTES:

1. GALVANIC ANODES NOT SHOWN FOR CLARITY. REFER TO SPECIFICATION 03800 FOR REQUIREMENTS.

NOT TO SCALE

	STANDARD DESIGN DETAIL	DRAWING NO. 635
	MECHANICAL SPLICE – OPTION 2 TYPICAL REBUILD SECTION	SHEET 1 OF 1
		DATE 2/2024

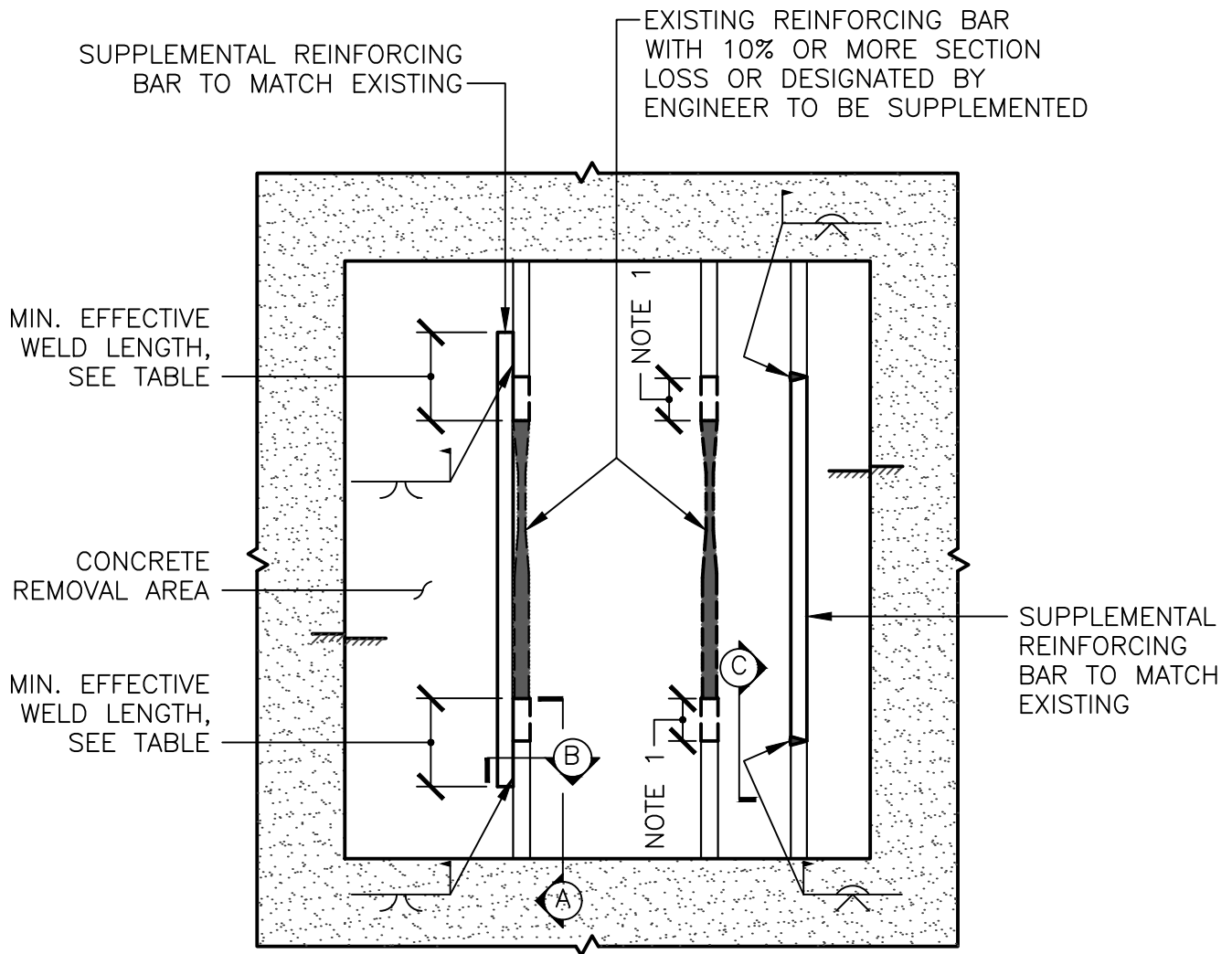

PLAN OR ELEVATION

NOTE 1: CUT BAR 3 INCHES MINIMUM BEYOND SECTION LOSS AND/OR CORROSION AND REMOVE

NOTE 2: SEE DETAILS 637 & 638 FOR SECTIONS

NOTE 3: GALVANIC ANODES NOT SHOWN FOR CLARITY. REFER TO SPECIFICATION 03800 FOR REQUIREMENTS.

NOT TO SCALE

	STANDARD DESIGN DETAIL	DRAWING NO. 636
	WELD SPLICE – OPTION 3	SHEET 1 OF 1
		DATE 2/2024

GRIND ALL EDGES SMOOTH
AFTER WELDING, TYP

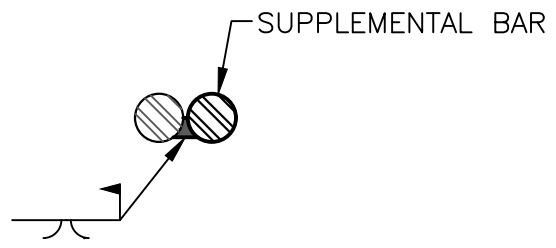
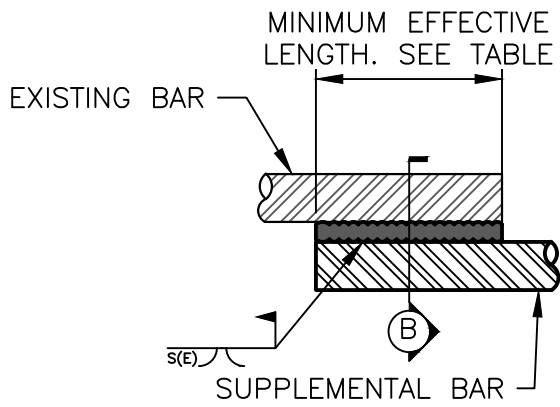

SECTION A – FLARE V – GROOVE WELD SPLICE

SECTION B

WELD SPLICE LENGTHS

BAR NO.	MINIMUM EFFECTIVE WELD LENGTH, in.	BAR RADIUS, S, in.
3	3.5	0.188
4	4.5	0.250
5	5.5	0.313
6	7.0	0.375
7	8.0	0.438
8	9.0	0.500
9	10.0	0.563
10	11.5	0.625
11	12.5	0.688

E-EFFECTIVE THROAT, 0.65
BASED ON E70XX ELECTRODES

NOT TO SCALE

	STANDARD DESIGN DETAIL	DRAWING NO. 637
	WELD SPLICE DETAILS – OPTION 3	SHEET 1 OF 1
		DATE 2/2024

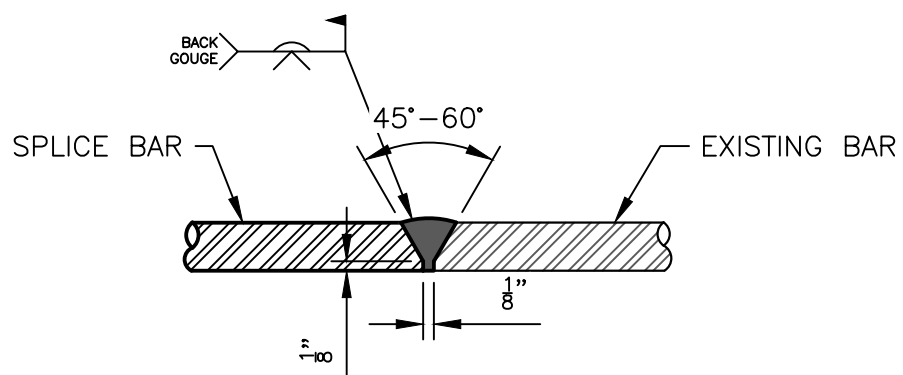

SECTION C - SINGLE V - GROOVE WELD SPLICE

NOT TO SCALE



STANDARD DESIGN DETAIL

WELD SPLICE DETAILS - OPTION 3

DRAWING NO.

638

SHEET

1 OF 1

DATE

2/2024

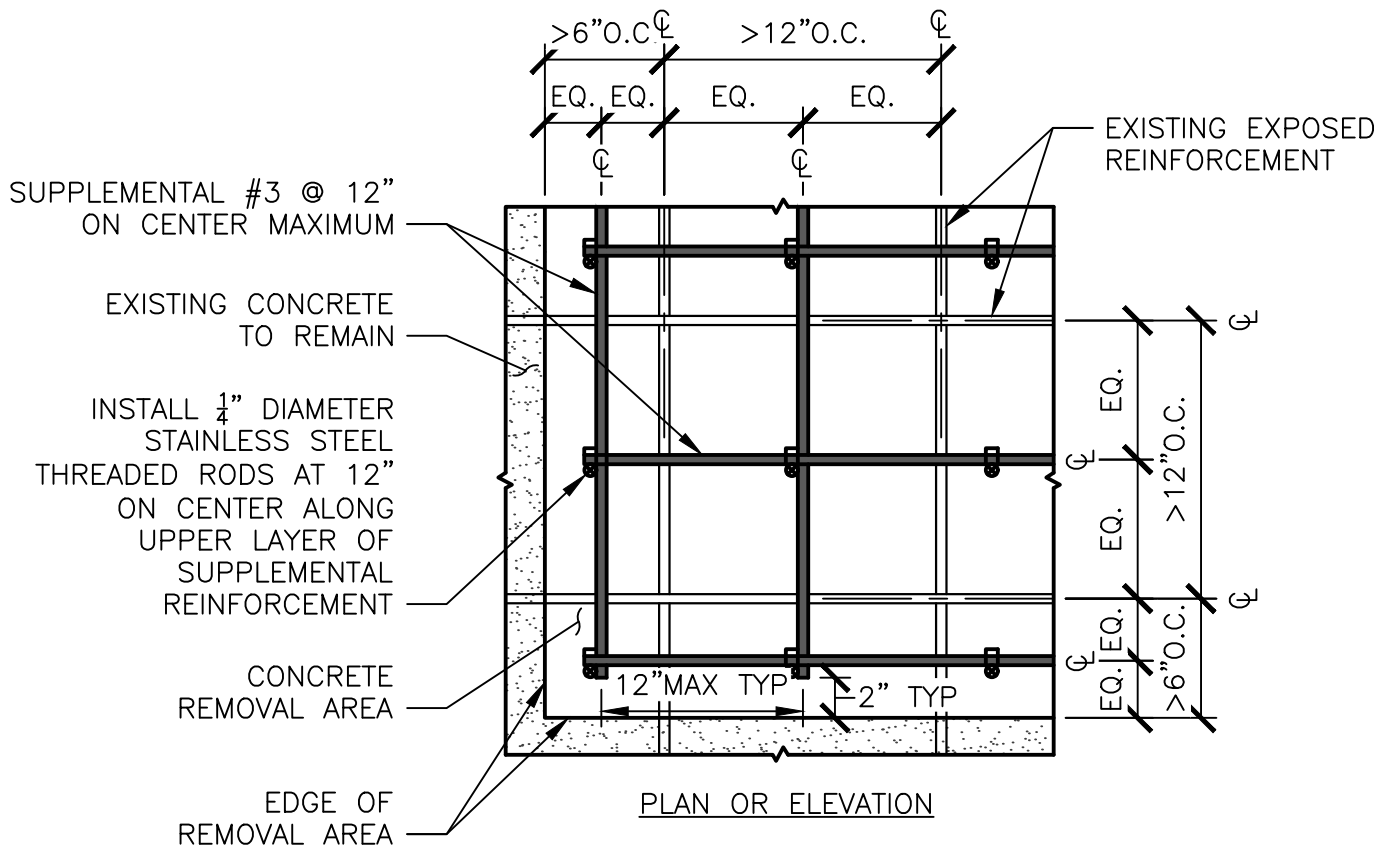

NOTES:

PROVIDE SUPPLEMENTAL REINFORCEMENT FOR EXISTING REINFORCEMENT THAT:

1. IS LOCATED 3" OR MORE BELOW NEW CONCRETE SURFACE; OR
2. HAS PROVIDED 2" MINIMUM CLEAR COVER, BUT SPACED GREATER THAN 12" O.C.
3. IS LOCATED 6" OR MORE FROM EXISTING CONCRETE TO REMAIN.

NOT TO SCALE

	STANDARD DESIGN DETAIL	DRAWING NO. 639
	SUPPLEMENTAL REINFORCEMENT REQUIREMENTS	SHEET 1 OF 1
		DATE 2/2024

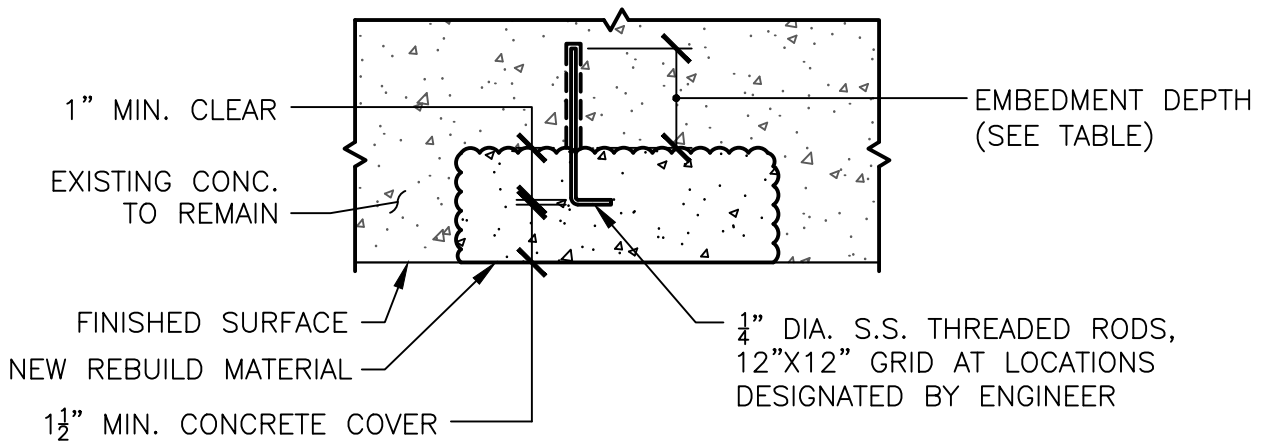

TYPICAL SECTION AT CONC. REMOVAL AREAS – VERTICAL AND OVERHEAD SURFACES

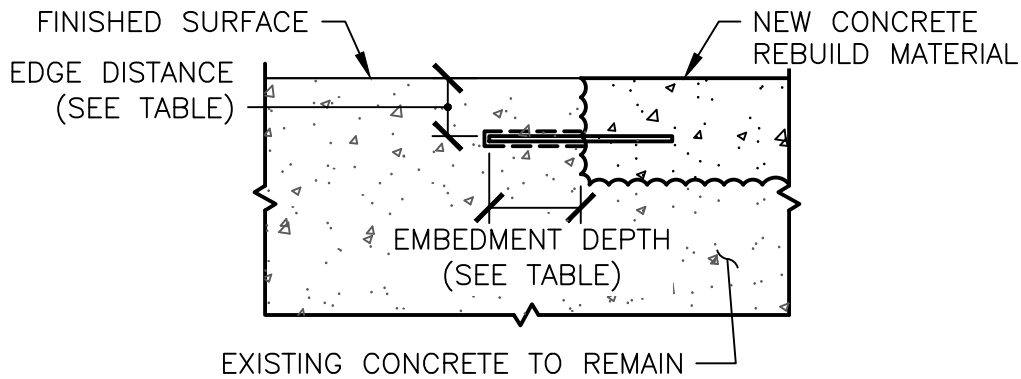

ADHESIVE-GROUTED DOWEL LAYOUT DIMENSIONS

DOWEL SIZE	ALLOWABLE TENSION LOAD PER ANCHOR, lbs	MINIMUM EMBEDMENT DEPTH, in.	MINIMUM CONCRETE THICKNESS, in.	MINIMUM EDGE DISTANCE, in.	MINIMUM SPACING, in.
1/4"Ø	950	3	6	4.0	8.0
#3	2,100	4	6	6.0	12.0
#4	2,800	4	6	6.0	12.0

NOTES:

1. TABLE VALUES FOR SINGLE ANCHORS IN TENSION ONLY; REINFORCING STEEL YIELD STRENGTH OF 60 KSI; THREADED RODS A276, TYPE 316, YIELD STRENGTH OF 30 KSI; HILTI HIT-HY 200 OR HILTI HIT-RE 500 V3 ADHESIVE, 4,000 PSI CONCRETE.

2. IF CONDITIONS ARE DIFFERENT THAN THOSE LISTED ABOVE, TABLE VALUES SHALL BE ADJUSTED BY A LICENSED PROFESSIONAL ENGINEER BASED ON ACTUAL DOWEL SYSTEM USED AND REQUIRED DOWEL CAPACITY.

NOT TO SCALE

	STANDARD DESIGN DETAIL	DRAWING NO. 640
	ADHESIVE-GROUTED DOWEL LAYOUT	SHEET 1 OF 1
		DATE 2/2024

DO NOT EXTEND
DEMOLITION BEHIND
EMBED PLATE GREATER
THAN 1" WITHOUT
APPROVAL OF ENGINEER

EXISTING CONCRETE
TO REMAIN

NEW CONCRETE
REBUILD MATERIAL

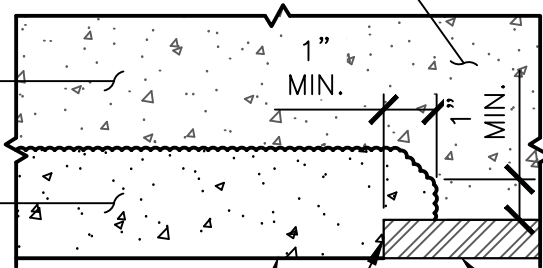

FINISHED SURFACE

EXISTING EMBED PLATE

EXTEND DEMOLITION & REBUILD
1" BEHIND EMBED PLATE; CLEAN
PLATE SURFACES & COAT W/
CORROSION-INHIBITING MATERIAL

REINF. NOT SHOWN FOR CLARITY,
REF. DETAILS 626 - 628
FOR REQUIREMENTS NOT
OTHERWISE SHOWN

NOT TO SCALE

HRSD

STANDARD DESIGN DETAIL

CONCRETE REBUILD
EMBED PLATE

DRAWING NO.

641

SHEET

1 OF 1

DATE

2/2024

DEMOLITION IS TYP. AT HORIZ. & VERT. LOCATIONS

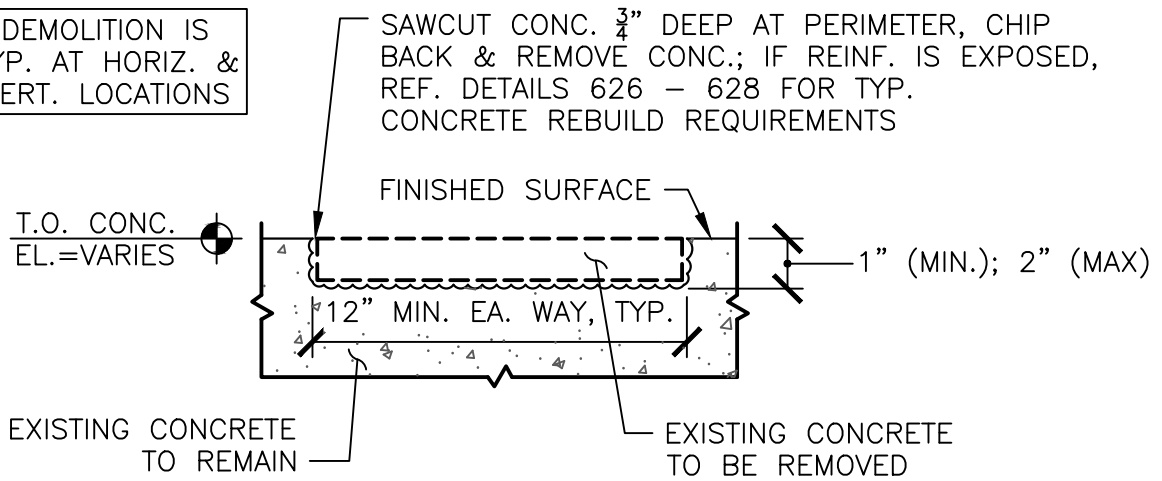

DEMOLITION

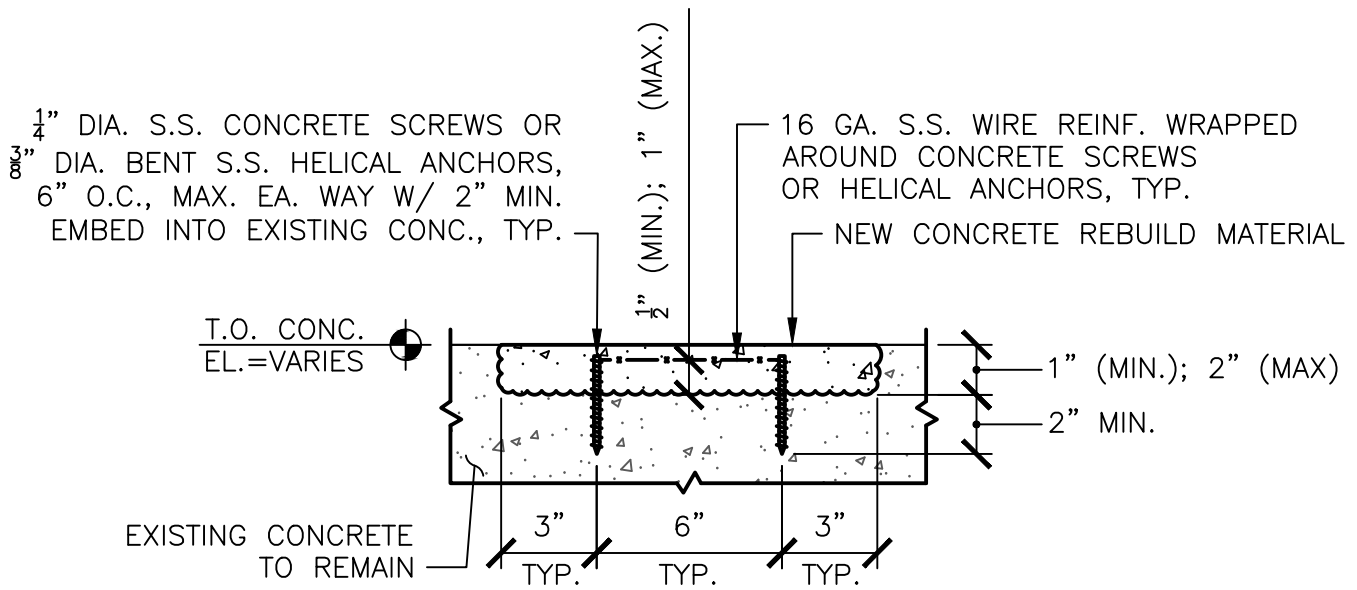

SHALLOW CONCRETE REBUILD – HORIZONTAL

NOT TO SCALE

	STANDARD DESIGN DETAIL	DRAWING NO. 642
	HORIZONTAL SHALLOW DEPTH (2"MAX) CONCRETE REBUILD	SHEET 1 OF 1
		DATE 2/2024

REF. DETAIL #642 FOR
TYPICAL DEMOLITION
REQUIREMENTS

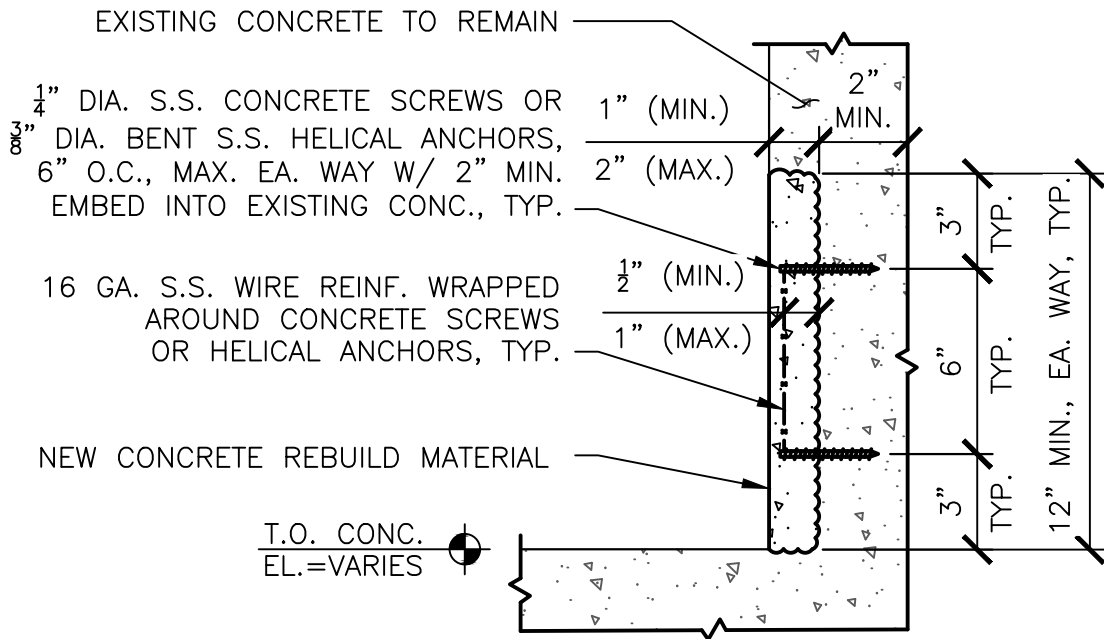

SHALLOW CONCRETE REBUILD – VERTICAL

NOT TO SCALE

	STANDARD DESIGN DETAIL	DRAWING NO. 643
	VERTICAL SHALLOW DEPTH (2" MAX) CONCRETE REBUILD	SHEET 1 OF 1
		DATE 2/2024

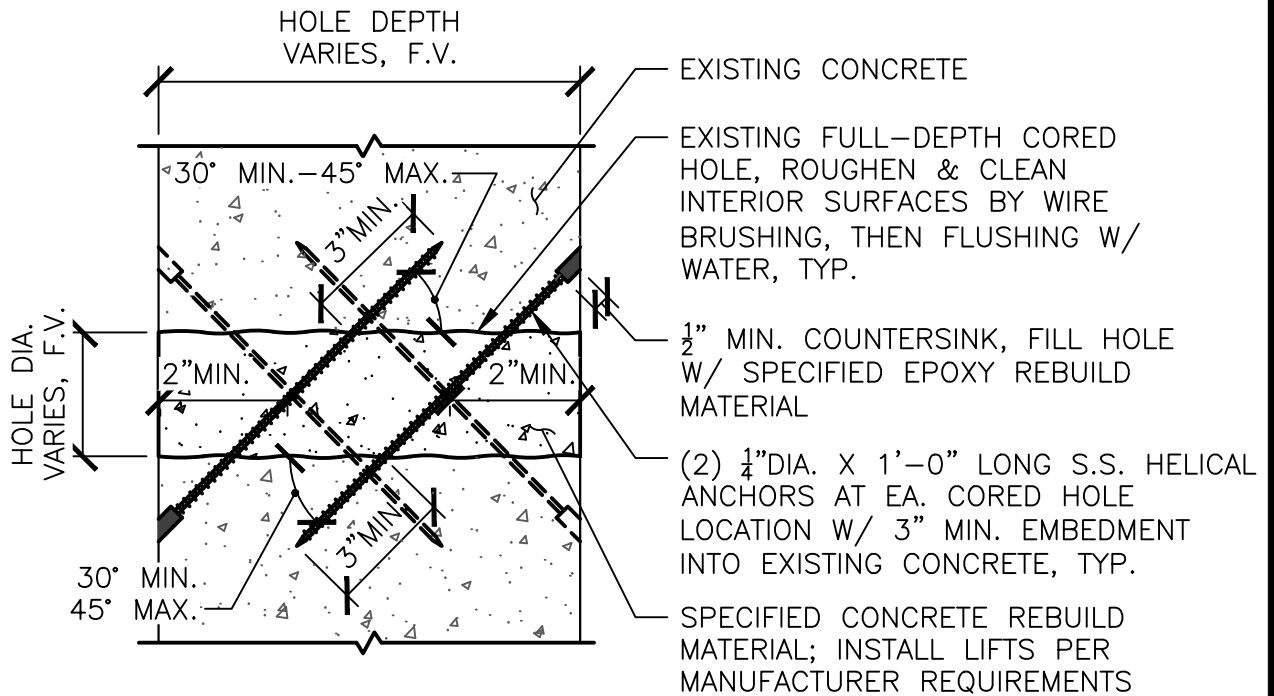

REBUILD SECTION

INSTALL ANCHORS AROUND PERIMETER OF CORED HOLE PER FIGURE BELOW, TYP.

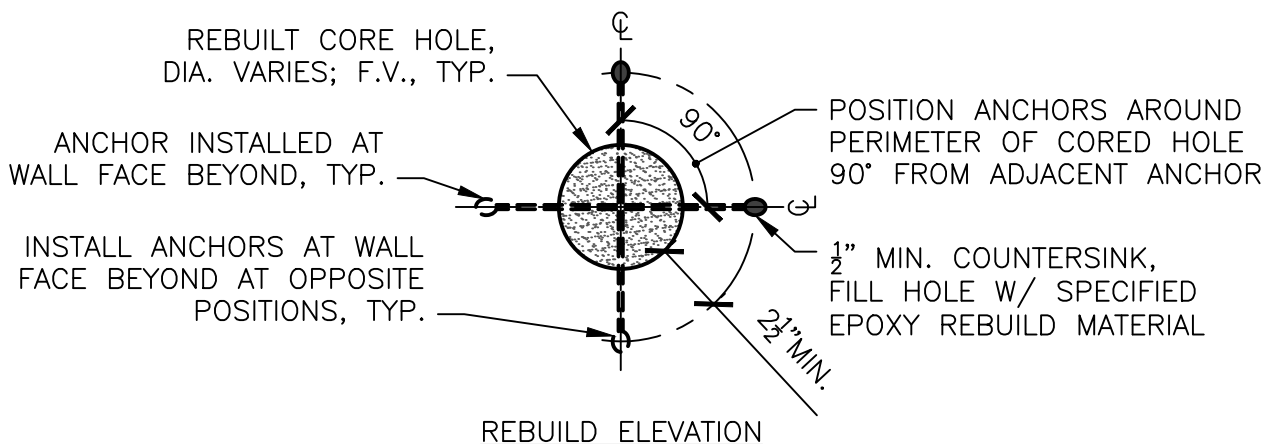

NOT TO SCALE

	STANDARD DESIGN DETAIL	DRAWING NO. 645
	FULL DEPTH CONCRETE REBUILD CORE HOLE	SHEET 1 OF 1
		DATE 2/2024

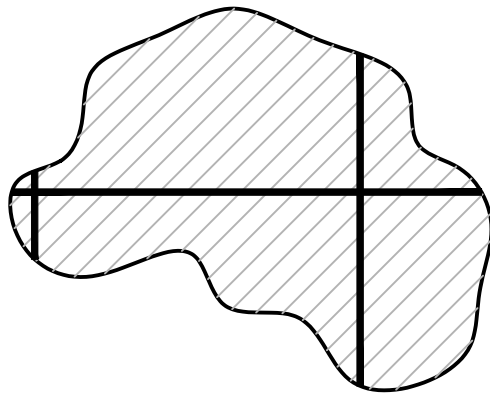

SEE DETAIL 646B FOR SECTION VIEW AND NOTES

NOT TO SCALE

	STANDARD DESIGN DETAIL	DRAWING NO. 646A
	SPALL REPAIR WITH EXPOSED REINFORCING STEEL	SHEET 1 OF 2
		DATE 2/2024

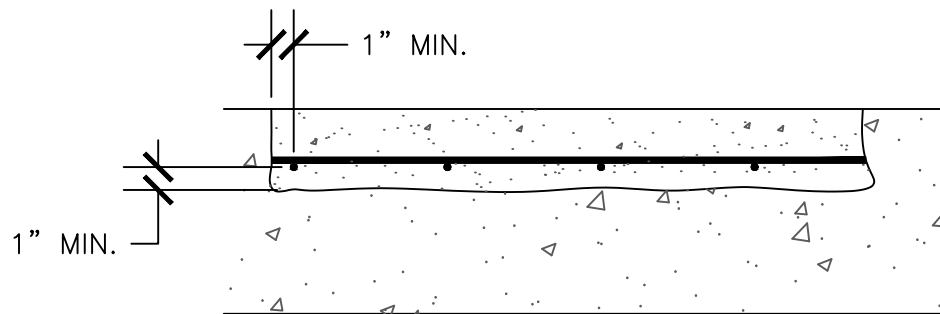

NOTES:

1. IF SECTION LOSS OF REBAR IN A MEMBER (SLAB AREA, BEAM OR COLUMN) EXCEEDS 25% THIS REPAIR SHALL BE REVIEWED BY A STRUCTURAL ENGINEER.
2. WATER BLAST OR SAND BLAST EXPOSED CONCRETE AND REBAR (SSPC5 WHITE METAL BLAST) IN SPALLED AREA.
3. CHIP OUT CONCRETE AROUND EXISTING REBAR TO LEAVE A ONE INCH SPACE (MIN.) BETWEEN REBAR AND CONCRETE. CHIP BACK FURTHER IF NECESSARY TO ACHIEVE SOUND CONCRETE.
4. ROUGHEN CONCRETE SURFACE, CLEAN DEBRIS AND DIRT FROM REPAIR AREA, COAT REBAR WITH CORROSION INHIBITOR. WET CONCRETE SURFACE PRIOR TO PLACING NEW CONCRETE.
5. CORROSION INHIBITOR SHALL MEET REQUIREMENT OF ASTM C1582.
6. CONCRETE SHALL HAVE A MINIMUM COMPRESSIVE STRENGTH OF ($f'c$) 5000 psi AT AN AGE OF 28 DAYS. MAXIMUM WATER-CEMENT RATIO (W/C) SHALL BE 40% BY WEIGHT. CEMENT SHALL BE ASTM C150 TYPE II WITH A MAXIMUM OF 0.6% ALKALIS BY WEIGHT. CONCRETE SHALL CONTAIN 7% SILICA FUME OR 15% FLYASH AS WEIGHT PERCENT OF CEMENTITIOUS MATERIALS.

	STANDARD DESIGN DETAIL	DRAWING NO. 646B
	SPALL REPAIR WITH EXPOSED REINFORCING STEEL	SHEET 2 OF 2
		DATE 2/2024

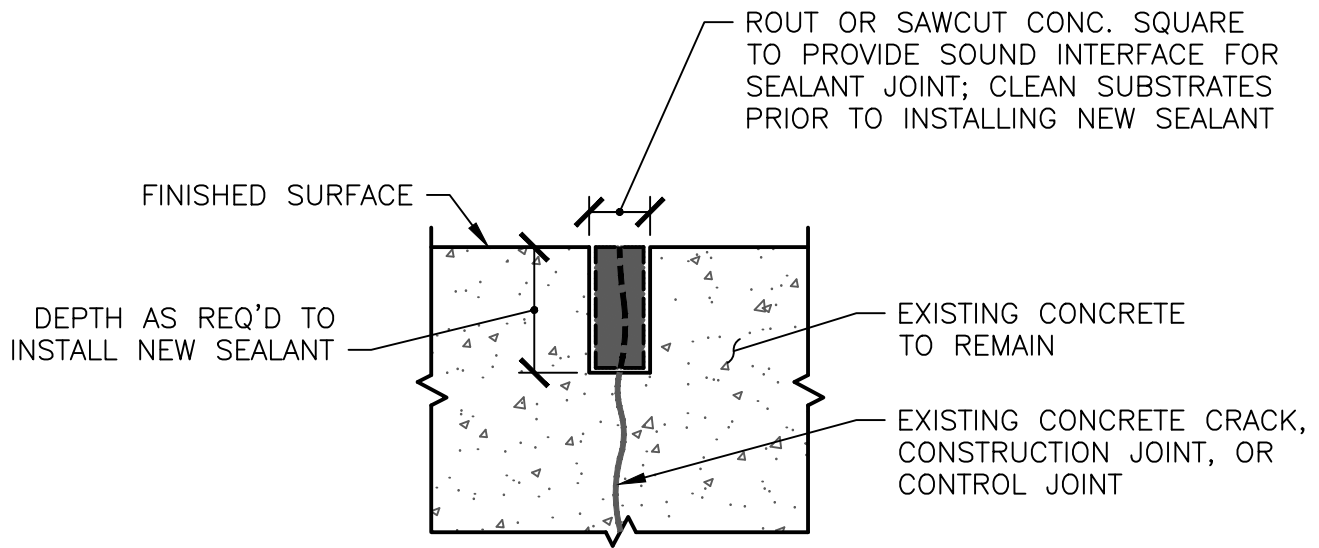

CONCRETE REMOVAL & SURFACE PREPARATION

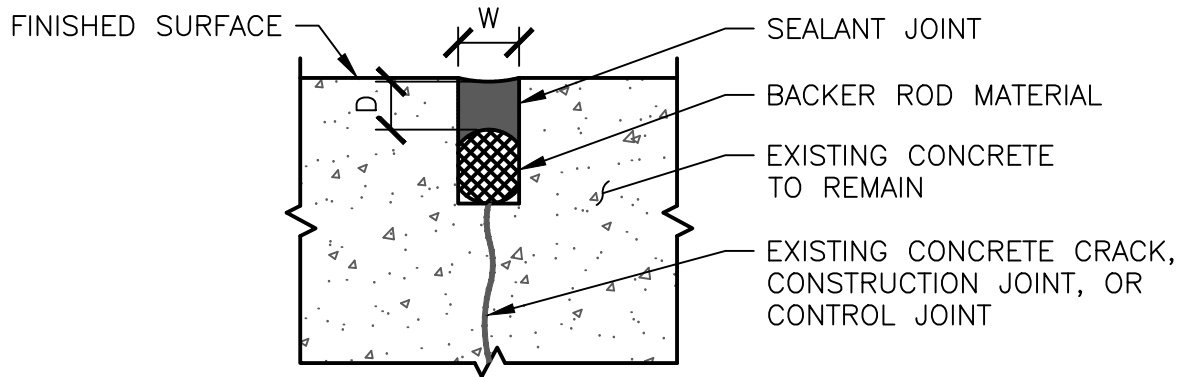

SEALANT JOINT INSTALLATION

HORIZONTAL SEALANT JOINT NOTES

1. IF $W < \frac{1}{2}$ "; $D = W$; $\frac{1}{4}$ " MIN.
2. IF $W > \frac{1}{2}$ " TO 1"; $D = (\frac{1}{2})W$
3. IF $W > 1$ "; $D = \frac{1}{2}$ "
4. ENSURE BACKER ROD DIA. IS 25%(±) LARGER THAN WIDTH OF THE JOINT, TYP.

NOT TO SCALE



STANDARD DESIGN DETAIL

JOINT SEALANT

DRAWING NO.

651

SHEET

1 OF 1

DATE

2/2024