

Section 32 - Treatment Plants

- I Purpose – HRSD historically has a broad range of experience with many different types of treatment processes and equipment. This section documents best practices and criteria for the design and operation of HRSD treatment plants. This section is intended to be practical and prudent based on HRSD’s history and experience. This section is to be followed wherever practical and used in conjunction with the other documents listed herein for standardization and consistency. This section is not meant to be a definitive design manual for treatment plant projects. This section provides typical standards and/or guidelines for work associated with the construction, modification and/or rehabilitation of HRSD Treatment Plants and associated infrastructure. The information herein has been developed based previous experience which includes successes, failures and lessons learned.
 - A. HRSD owns and operates various wastewater treatment plants. These plants consist of various unit processes, which are divided into Sewage Treatment, SWIFT Advanced Water Treatment, and Solids Handling.
 1. Sewage Treatment (ST): These processes typically consist of a preliminary process, a primary process, and a secondary process, which purify the liquid wastewater entering the treatment plant before it is discharged to the receiving stream, recycled for water reuse, or conveyed to SWIFT advanced treatment and aquifer recharge.
 2. SWIFT Advanced Water Treatment: SWIFT advanced water treatment facilities take highly treated water from HRSD’s wastewater treatment plants and treats it further to meet drinking water quality standards. The SWIFT water is then used to recharge the Potomac Aquifer.
 3. Solids Handling (SH): These processes typically consist of a thickening process, a dewatering process, and a solids disposal process, which dispose of or recycle the solid residuals produced from purifying the liquid wastewater.
 4. Side Stream Treatment: The processes which treat liquid recycles from the solids handling process to reduce nutrient or inhibitory compound loading at the head of the plant.
 - B. HRSD treatment plants are designed and operated to:
 1. Meet all regulatory requirements.
 2. Prevent offsite nuisance conditions.
 3. Be safe and reliable.

4. Use proven equipment where applicable.
 5. Use automation and technology to minimize operating cost and maximize efficiency.
 6. Optimize life cycle cost.
- C. Planning for new HRSD treatment plant facilities and projects is outlined in these documents:
1. Solids Management Master Plan – Provides long-term planning to evaluate solids production, solids handling capabilities and deficiencies, and required new solids handling facilities for current and future conditions.
 2. Capital Improvement Program (CIP) – Provides planning to initiate new projects.
- D. Design and operating criteria for HRSD treatment plants are also outlined in the following documents:
1. Interceptor System Policies – Provides design and operating criteria for HRSD interceptor systems and local collection systems.
 2. HRSD Design and Construction Standards – Provides design and construction standards for new projects.
 3. Commonwealth of Virginia Sewage Collection and Treatment (SCAT) Regulations – Provides design and operating criteria for sewerage systems and sewage treatment works in Virginia.
 4. Hydraulic Institute Standards – Provides industry standards for the design, material, methods, performance, testing, etc. for hydraulic pumps and associated elements.
 5. HRSD Standard Functional Descriptions.
- E. The design and operation of HRSD treatment plants shall seek balance between design based on the way treatment plants are operated and operation based on the way treatment plants are designed.
- F. Design of HRSD facilities should provide for occupancy, maintenance, and storage requirements such as conference rooms, restroom and locker room facilities, lunch room, storage area, maintenance work areas, office areas, etc.

- G. Design for power failures and power failure restarts to ensure equipment fails and restarts in appropriate condition to protect personnel, facilities, and process.

II Abbreviations - The following abbreviations shall be used on the construction documents for all treatment plant related projects.

Abbreviation	Definition
ANOX	Anoxic
ANAE	Anaerobic
AER	Aerobic
AAA	Anaerobic/Anoxic/Aerobic
AAE	Anaerobic/Anoxic Effluent
AI	Aeration Influent
ALUM	Alum Solution
ANE	Anaerobic Effluent
APD	Acid Phase Digester
APDS	Acid Phase Digester Solids
API	Acid Phase Influent
APRS	Acid Phase Recirculation Solids
ARCY	Anoxic Recycle
ARE	Aerated Effluent
AS	Air Supply (Low Pressure Process Air)
ASR	Aerated Supernatant Return
AWT	Advanced Water Treatment
AXE	Anoxic Effluent
BAF EFF	Biofilter Effluent
BAF INF	Biofilter Influent
BAS	Backwash Air Supply
BLWR	Blower
BWS	Backwash Water Supply
BWW	Backwash Waste
BWWR	Backwash Waste Recycle
CCK	Centrifuge Biosolids Cake
CCT	Centrifuge Dewatering Centrate/Chlorine Contact Tank
CCWS	Closed Loop Cooling Water Supply
CCWR	Closed Loop Cooling Water Return
CENT	Centrifuge
CNE	Centrate Equalization
CLS	Chlorine Solution
CSP	Cake Storage Pad
CST	Caustic Storage Tank
CTC	Centrifuge Thickening Centrate
CTI	Centrate Treatment Influent
CTP	Centrate Treatment Process

Abbreviation	Definition
CTS	Centrifuge Thickened Biosolids
CTE	Centrate Treatment System Effluent
DA	Polymer Dry Air
DAF	Dissolved Air Flotation Thickener
DCE	Dewatering Centrate
DCS	Distributed Control System
DGAS	Digester Gas
DI	Ductile Iron
DIG	Digester
DIST CH	Distribution Chamber
DPOLY	Dry Polymer
DPSD	Drain Pump Station Discharge
DS	Digested Solids
DSR	Decant Supernatant Return
DTD	Decant Tank Drain
FD	Floor Drain
FE	Filtrate Effluent
FERRIC	Ferric Chloride/Sulfate
FI	Filtrate Influent
Filter Aid Poly	Filter Aid Polymer
FLOC INF	Flocculation Influent
FNE	Final Effluent
FOG	Fats, Oils, and Grease
FOP	Fuel Oil Pump
FOS	Fuel Oil Supply
FOR	Fuel Oil Return
FRP	Fiberglass Reinforced Plastic
FSB	Dissolved Air Flotation Thickener Subnatant
FTS	Dissolved Air Flotation Thickener Solids
FTW	Filter to Waste
GAC	Granular Activated Carbon
GAC EFF	GAC Effluent
GAC INF	GAC Influent
GAC SD	GAC Slurry Drain
GAC SF	GAC Slurry Fill
GBFL	Gravity Belt Filtrate
GBT	Gravity Belt Thickener
GBTS	Gravity Belt Thickened Solids
GBWS	GAC Backwash Supply
GBWW	GAC Backwash Waste
GOX	Gaseous Oxygen
GPD	Gas Phase Digester
GPDS	Gas Phase Digested Solids

Abbreviation	Definition
GPE	Gas Phase Effluent
GPI	Gas Phase Influent
GPRS	Gas Phase Recirculation Solids
GRIT	Grit
GSP	Gravity Thickener Overflow/Supernatant
GTS	Gravity Thickened Solids
GTW	GAC to Waste
H2O2	Hydrogen Peroxide
HDOIL	Hydraulic Oil
HDPE	High Density Polyethylene pipe
HW	Headworks
HWP	Hot Water Pump
HPW	Hot Potable Water
HWR	Hot Water Return
HWS	Hot Water Supply
IPS	Intermediate Pump Station
ISW	Incinerator Scrubber Water
LAS	Liquid Ammonium Sulfate
LOX	Liquid Oxygen
LPROP	Liquid Propane
LPOLY	Liquid Polymer
METH	Methanol
MLSS	Mixed Liquor Suspended Solids
MURIATIC	Muriatic Acid
MWS	Monitoring Well Sample
NAT GAS	Natural Gas
NH2CL	Monochloramine
NPW	Non-Potable Water
NRCY	Nitrified Recycle
O3SAMP	Ozonated Water Sample
OA	Odorous Air
OCF	Odor Control Fan
OCS	Odor Control Scrubber
OCWR	Open Loop Cooling Water Supply
OCWS	Open Loop Cooling Water Return
OD	Ozone Destruct
OFF SPEC	SWIFT Off Spec
OZONE	Ozone Gas
PCE	Primary Clarifier Effluent
PCI	Primary Clarifier Influent
PCS	Primary Clarifier Solids
PD	Process Drain
PDS	Primary Digested Solids
PDSP	Primary Digester Supernatant

Abbreviation	Definition
PHOS A	Phosphoric Acid
POLY	Polymer
POLYS	Polymer Solution
PTF	Preliminary Treatment Facility
PW	Potable Water
RAS	Return Activated Solids
RCP	Recirculation Pump/Reinforced Concrete Pipe
RCCP	Reinforced Concrete Cylinder Pipe
RD	Roof Drain
REAER	Reaeration
RWI	Raw Wastewater Influent
SA	Service Air
SAMP	Sample
SBD	Scrubber Blowdown
SBR	Sequencing Batch Reactor
SC	Secondary Clarifier
SCB	Scum Concentrator Subnatant
SCE	Secondary Clarifier Effluent
SCI	Secondary Clarifier Influent
ST	Sidestream Treatment
SCN	Supplemental Carbon Neat/Screen
SCS	Supplemental Carbon Solution
SCUM	Scum
SD	Storm Drain
SDS	Secondary Digested Biosolids
SDSP	Secondary Digester Supernatant
SEPT	Septage
SES	Settled Solids
BISULF	Sodium Bisulfite
CAUSTIC	Sodium Hydroxide
HYPO	Sodium Hypochlorite
SFW	Softened Water
SP	Sump Pump
SPD	Sump Pump Discharge
SPRAY	Spray Water
SR	Supernatant Return
SRC	Scrubber Recirculation Cleaning
SRD	Scrubber Recirculation Discharge
SRS	Scrubber recirculation Suction
SS	Sanitary Sewer
SSFM	Sanitary Sewer Force Main
ST	Sewage Treatment
STEAM	Steam
STW	Settled Water

Abbreviation	Definition
SW	Seal Water
SWIFT	SWIFT Water TM
SWIFT NPW	SWIFT Non Potable Water
TS	Thickened Solids
TSR	Thickener Supernatant Return
TWAS	Thickened Waste Activated Solids
UIC	Underground Injection Control
UF EFF	UV Effluent
UW	Utility Water
V	Vent
WAS	Waste Activated Solids
WBF	Well Backflush
WSP	Welded Steel Pipe

III Sewage Treatment Design and Operation

- A. Regulations – The design and operation of sewage treatment facilities should be in accordance with all provisions of the approved SCAT Regulations.
- B. Design Life – The design life of sewage treatment facilities should be greater than or equal to the following:
- C. Structures: 50 years
- D. Piping and Conveyance: 50 years
- E. Mechanical Equipment: 20 years
- F. Electrical Power Equipment: 20 years
- G. Instrumentation And Control Equipment: 5 to 10 years
- H. Flood Elevations – The flood elevations for sewage treatment unit processes should be based on the historical flood elevations listed below except on a case-by-case basis to meet existing or unusual conditions or where the discharge is to sensitive receiving waters:
 - 1. 25 Year Flood Elevation to remain fully operational.
 - 2. 100 Year Flood Elevation to protect structures housing critical operating equipment from flooding.

- I. Operating Elevation, Design Flow – Consult with the Hydraulic Analysis Review Team (HART) report to determine design criteria if applicable or obtain hydraulic data from HRSD Hydraulic Analysis Managers.
- J. Nutrient Removal
 - 1. Provide consistent tank nomenclature at Biological Nutrient Removal (BNR) plants. Engineering documents and drawings should use this nomenclature.
 - a. “1st Anoxic Zone” is correct. Do not use “Pre-anoxic zone”.
 - b. “2nd Anoxic Zone” is correct. Do not use “Post-anoxic zone”.
 - c. Number multiple cells within an Anoxic or Aerobic zone according to the flow direction in the tank; for example: 2nd Anoxic Zone, Cell 1; 2nd Anoxic Zone, Cell 2; 2nd Anoxic Zone, Cell 3.
 - d. For step feed process, use “1st Anoxic Zone”, “2nd Anoxic Zone”, “3rd Anoxic Zone”, etc and “1st Aerobic”, “2nd Aerobic”, “3rd Aerobic”, etc.
 - e. For Bardenpho processes, use “Aerobic Zone” and “Reaeration Zone”.
- K. Design Loadings – The design loadings for sewage treatment unit processes should be based on the maximum monthly wastewater flow and the maximum month mass loading for cBOD, COD, TSS, TP, and TN. The maximum month loading and projected growth should be based on historical records, field sampling or similar experience. Include the impacts of septage discharge, chemical addition and recycle loads on the maximum monthly concentrations. Base recycle loads on historical records. If accurate data is not available, consider a minimum of a 10% recycle of cBOD, TSS, P and N as appropriate from solids handling. Peak loadings (such as peak weekly loadings or peak hourly loadings where typically used for process design) should be as recommended by the design engineer. Identify all flows, concentrations and loadings used for the design of unit processes in the design documents.

Water conservation has caused a general decrease in flow and corresponding increase in concentrations of cBOD, TSS, P and N. This trend may significantly change the original design loadings at some treatment plants where sewage treatment and/or solids handling unit processes become limited by cBOD and TSS loadings before the design flow is reached unless additional aeration and/or solids handling capacity is available. Sewage treatment and solids handling unit processes should

be designed to accommodate this trend by using higher influent concentrations as appropriate so as to fully utilize the design flow of the treatment plants. Sewage treatment and solids handling unit processes should be designed to accommodate this trend by using higher influent concentrations. Recommended values for new residential neighborhoods are: BOD = 297 mg/L, TSS = 282 mg/L, TKN = 57 mg/L, and TP = 7.0 mg/L ("HRSD Rate Schedule Fiscal Year 2024).

- L. Design For Initial Plant Startup – The design for initial plant startup should provide for efficient and economical operation of sewage treatment unit processes without problems caused by oversized tanks and equipment if low flows are expected during early years of operation. The design for initial plant startup may incorporate:
 - 1. Sufficient turndown capability
 - 2. Additional smaller initial equipment to be operated only at lower flows.
 - 3. Multiple smaller initial equipment to be operated together at higher flows.
- M. Outfalls And Outfall Diffusers – Consult with the (HART) report to determine design criteria if applicable or obtain hydraulic data from HRSD Hydraulic Analysis Managers.
- N. Reliability And Redundancy – The reliability and redundancy of major sewage treatment equipment should be the ability to take any one unit process train out of service at design flow as long as all unit process trains of all other unit processes remain in service. Verify that the design complies with SCAT Regulations.
- O. Equipment Selection – The current, approved list of sole-source equipment can be found on SharePoint site under Finance / Sole Source/ COMMISSION APPROVED SOLE SOURCE ITEMS. Users without SharePoint access may request this document by contacting the Engineering Department.
- P. Minimum Requirements:

Sewage Treatment Unit Process	Min. No. of Units Installed	No. of Units Out of Service	Comments
Flow Measurement	1	0	<p>Provide flow measurement with totalizer. FNE is preferred over RWI. Internal recycle streams are to be separate (after RWI measurement or prior to FNE measurement).</p> <p>Consider parshall flume, venturi, or magmeter. Employ only flow meter equipment that is accurate and non-ragging/self-cleaning.</p>
Influent Pumping			
Pumps	Minimum 3 units (includes one spare) Firm capacity to be determined by HRSD Planning & Analysis of 2.5 times design flow Meet firm capacity with largest unit out of service	1	Provide for all pumps to be variable speed. The 1 st pump runs continuously, the 2 nd pump starts when 1 st pump cannot handle all of the flow. Additional pumps run when 1 st and 2 nd pumps cannot handle flow or upon failure of 1 st or 2 nd pump.
Wet Wells/ Channels	As required	As required	<p>Consider self-cleaning wet wells. Match size and controls to pumping requirements to prevent frequent start/stop of pumps. Consider means to remove wet wells and enclosed channels from service in the future for maintenance of concrete and coatings. Provide for personnel access into wet well.</p> <p>Provide protective lining or coating at linear trench style self-cleaning wet wells for RWI service.</p>
Automatic Actuators	-	-	Provide automatic actuators on all critical control gates and valves. Consider remote DCS control and provide at a minimum position indication.

Sewage Treatment Unit Process	Min. No. of Units Installed	No. of Units Out of Service	Comments
Isolation Gates	-	-	<p>Provide secondary means of closure at all gates. Stop logs or Stop Gates may be considered provided they:</p> <ul style="list-style-type: none"> meet the same AWWA leakage rates specified for slide gates are engineered and composed of: <ul style="list-style-type: none"> FRP encapsulated A36 steel or 304 SST for the stop log / stop gate panel neoprene rubber for the seals SST for the slide frame and hardware with replaceable UHMW guide strips and neoprene guide seals. have logs that are a minimum of 3-1/2" thick with opposing bottom-mounted dual "J" seals have surface mounted slide channel frame guides permanently installed in channel walls with a flat bottom sealing surface (no sealing keyway/grove) for the stop logs to seal against, have a mechanical galvanized lifting beam assembly to place and retrieve the stop log or stop gates are mounted in areas accessible to a portable gantry for use with the lifting beam assembly. If not, a permanent gantry or jib must be installed and positioned to accommodate log/gate installation and extraction.
Bar Screens	2 minimum; Sized for 2.5 x annual average wastewater flow rate with largest unit out of service	1	<p>Size to protect plant during severe storm flow conditions. Provide coarse screen bypass channel. Screenings are to be sluiced to a compactor. Dewater screenings using press or similar equipment. Discharge screenings into bulk storage containers. Minimum two containers, each sized for one screen. Manifold discharge screenings to multiple containers. Locate containers inside enclosed building with odor control.</p>

Sewage Treatment Unit Process	Min. No. of Units Installed	No. of Units Out of Service	Comments
Center Flow Band Screens and Drum Screens	2 minimum; Sized for 2.5 x annual average wastewater flow rate with largest unit out of service	1	Size to protect plant during severe flow conditions. Band screens are to have internal bypass overflows (bypass channel not required). Screenings are to be sluiced to a compactor. Discharge screenings into bulk storage containers. Minimum two containers, each sized for one screen. Manifold discharge screenings to multiple containers. Locate containers inside enclosed building with odor control.
Step Screens	2 minimum; Sized for 2.5 x annual average wastewater flow rate with largest unit out of service	1	Size to protect plant during severe flow conditions. Provide coarse screen bypass channel for emergency use. Screenings are to be sluiced to a compactor. Discharge screenings into bulk storage containers. Minimum two containers, each sized for one screen. Manifold discharge screenings to multiple containers. Locate containers inside enclosed building with odor control.
Grit Removal Tanks	2 minimum; Sized for 2.5 x annual average wastewater flow with largest unit out of service	1	Size to protect plant during severe storm flow conditions. Consider only detritors, stacked vortex (Head Cell), or structured vortex (Grit King). Avoid aerated grit, forced vortex, and velocity channels (grit channels). Consider collection system diurnal velocities for deposition of grit and storm slug loads.
Grit Pumps	2 per tank	1	Size each unit to handle total tank loading. Do not provide interconnection between tanks. Minimum grit pipe diameter is 6-inch. Minimum grit pump suction / discharge size is 4-inch / 4-inch. Provide flushing water on suction side of pumps.
Classifiers	2 per tank	1	Size each unit to handle total tank loading.

Sewage Treatment Unit Process	Min. No. of Units Installed	No. of Units Out of Service	Comments
Hopper	1	0	Discharge all classifiers into 1 hopper. Locate hopper inside enclosed building with odor control.
Pre-Aeration	-	-	Do not use.
Primary Clarifiers Tanks	3 sized for design loadings	1	Prefer center feed, circular units if space available due to less maintenance and better thickening. Consider separate fermenter for BNR if circular units used. For circular tanks, evaluate stainless steel rake and scum systems, FRP weirs/wells, SS center pier.
Solids Pumps	1 dedicated pump per clarifier with 1 spare pump per 2 or 3 clarifiers	1	Provide turndown capability or smaller pumps for low flow requirements at initial plant startup with provisions to replace smaller pumps as plant expands. Provide grinder or solids screen with bypass line ahead of each pump. Pumps with internal cutting blades can be considered if grinder installation is not practical due to space limitations.
Intermediate Pumping			Refer to Pump subheading in Influent Pumping.
Aeration Tanks	3 minimum; accommodate 2.5 times design flow with one tank out of service	1	Provide foam re-entrainment and/or foam removal.
Blowers	3 sized for design loadings with largest unit out of service	1	Provide turndown capability or 2 smaller blowers approximating 1 larger blower for low air requirements at initial plant startup with provisions to replace smaller blowers or install additional blowers as plant expands. Provide automatic start/stop and air control. Refer to HRSD Standard Functional Descriptions for control regimes. Locate blowers near aeration tanks to minimize air piping.

Sewage Treatment Unit Process	Min. No. of Units Installed	No. of Units Out of Service	Comments
Air Piping	-	-	Locate air piping above ground or in tunnels; do not bury.
Air Diffusers	-	-	Fine bubble diffused air system.
Secondary Clarifiers Tanks	3 minimum; accommodate 2.5 times design flow with one tank out of service	1	
RAS Pumps	1 dedicated pump per clarifier with provision for adequate number of spare pumps	1	Provide variable speed pumps sized for total dedicated pump capacity of 1.0 x maximum monthly wastewater flow.
WAS Pumps	2 typically pulling off RAS discharge	1	Provide turndown capability or smaller pumps for low flow requirements at initial plant startup with provisions to replace smaller pumps as plant expands.
Chlorine Contact Tanks	2 sized for design flows	1	Provide 30 minutes detention time at maximum monthly wastewater flow (corresponding to SCAT terminology of average daily wastewater flow) or 20 minutes at 2.0 x maximum monthly wastewater flow (corresponding to SCAT terminology of maximum daily wastewater flow) whichever is greater with largest unit out of service. Provide scum removal system.
Effluent Pumping Pumps	3 sized for 2.5 x design wastewater flow with largest unit out of service	1	Provide variable speed pumps. Controls shall conform to HRSD Standard Functional Description.
Wet Well	-	-	Match size and controls to pumping requirements to prevent frequent start/stop of pumps. Locate close to chlorine contact tanks. Provide scum removal system.

Sewage Treatment Unit Process	Min. No. of Units Installed	No. of Units Out of Service	Comments
Non-Potable Pumps and Automatic Strainers	3	1	May need additional pumps for multiple purposes, wide flow range, or low flow requirements at initial plant startup. Locate suction before dechlorination. Refer to HRSD Standard Functional Descriptions for control. Ensure complete by-pass capabilities for strainer maintenance.
Scum Removal Wells and Holding Tanks	-	-	Provide for agitation to break up crusted scum and automatic pump out of scum without excessive water. Consider morning glory / tee valve to minimize water content of pumped scum.
Scum Transfer Pumps	2 per well or holding tank	1	Provide grinder ahead of each pump. Do not use air operated diaphragm pumps.
Scum Piping	-	-	Minimum 4-inch diameter. Corrosion-resistant glass lined ductile iron, HDPE, or PVC. Long radius bends, cleanouts, NPW flushing connections.
Concentrator	2	1	
Concentrated Scum Pumps	2 per concentrator	1	Do not use air operated diaphragm pumps.
Concentrated Scum Piping	-	-	Maximum 4-inch diameter. Corrosion-resistant glass lined ductile iron, PVC, or HDPE. Long radius bends, cleanouts, NPW flushing connections, and air connection at injection point to furnace.
Chemical Feed Systems Pumps	1 dedicated pump per feed point with 1 spare pump connected to manifold	-	Provide turndown capability or range of pump sizes to accommodate low flow and high flow requirements. Flow meters to read accurately at all anticipated flow ranges.
Odor Control Enclosed Facilities and Covered Tanks	-	-	Consider on case by case basis.

Sewage Treatment Unit Process	Min. No. of Units Installed	No. of Units Out of Service	Comments
Scrubbers	2 trains of 2 scrubbers each including standby train for sewage treatment	1 train	Consider 1 large odor control station versus multiple smaller odor control stations on case by case basis. Provide additional trains for large air flows. Consider bioscrubbers and carbon scrubbers where applicable.
	2 scrubbers including standby scrubber for solids handling where single stage scrubbing is appropriate or as above for sewage treatment where two stage scrubbing is required	1 scrubber	Provide for chemical cleaning of scrubbers.
Emergency Power Generators	1 sized on case-by-case basis to power all sewage treatment operations at 2.5 x maximum monthly wastewater flow plus critical solids handling operations on a case-by-case basis	0	Satisfy Class I Reliability requirements. Provide emergency generator(s) rated to adequately power required plant loads. Provide sufficient fuel storage for a 7 consecutive day utility outage at full load.
UPS	-	-	Provide backup power for sufficient time at control stations for critical computer, data collection and I&C functions.

IV SWIFT Facilities Design and Operation:

- A. Regulations – the design and operation of SWIFT facilities for aquifer recharge is regulated through the EPA’s Underground Injection Control (UIC) program. The Potomac Aquifer Recharge Oversight Committee is an advisory board that provides independent monitoring and oversight of the SWIFT program. The Committee consists of a 10-member advisory panel including representatives from VDH, VA DEQ, the HRPDC, and the public.
- B. Design life – Design life for SWIFT facilities shall match the design life for sewage treatment facilities detailed in Section 31.C.2.
 - 1. SWIFT treatment capacity – SWIFT treatment and aquifer recharge facility capacities are determined based on achieving SWIFT capture rate and SWIFT facilities utilization targets.
 - 2. The SWIFT capture rate describes the percentage of wastewater effluent that is treated by SWIFT AWT process. It is defined as the influent flow to the SWIFT AWT facility(s) divided by the effluent flow (typically either secondary clarifier effluent or tertiary treatment effluent) from the wastewater treatment facility(s).
- C. The SWIFT facility utilization compares actual SWIFT AWT aquifer recharge production compared with the available SWIFT AWT and aquifer recharge production capacity. It is defined as the influent flow to SWIFT AWT facility(s) divided by the SWIFT AWT facility(s) design treatment capacity.
- D. SWIFT integration – Integration of SWIFT facilities shall consider impacts to plant NPW water systems, impacts to wastewater disinfection processes and associated permit requirements, nutrient removal processes, treatment plant solids handling and disposal practices, outfall infrastructure operations and maintenance, and the interface with electrical and instrumentation systems.
- E. Design loadings – Design parameters and loadings shall be in accordance with the stipulations as defined in the EPA UIC permit.
- F. Equipment selection – The current approved list of sole-source equipment can be found on HRSD’s SharePoint under Finance/Sole Source Library\.. Users without SharePoint access may request this document by contacting the Engineering Department.
- G. Minimum Requirements

SWIFT Unit Process	Minimum Number of Units Installed	Number of Units Out of Service	Comments
Rapid Mix	2	1	
Flocculation	2 sized for design residence time w/ one unit out of service	1	
Sedimentation	2 sized for design overflow rate w/ one unit out of service	1	If inclined plates are used, plate efficiency shall be 80% and plate angle shall not be less than 55°.
Ozone Generation	2	1	Selection of ozone generators shall consider maintaining economical use of power and oxygen over the expected range of operating conditions.
Ozone Contact	1 (if pipeline or serpentine contactor used) 2 (if over-under contactor used)	0 (if pipeline or serpentine contactor used) 1 (if over-under contactor used)	
Biofiltration	2 sized for design empty bed contact time w/ one unit out of service	1	Evaluation for number of biofilters should optimize the number of filters based on individual filter size, overall facility footprint, backwash flow (pumps, piping, backwash supply and waste volume requirements, and number of filters.
GAC Adsorption	2 sized for design empty bed contact time w/ one unit out of service (1 unit in backwash)	1	Evaluation for number of GAC contactors should optimize the number of contactors based on individual unit size, overall facility footprint, backwash flow (pumps, piping, backwash supply and waste volume requirements, and number of units.

			Evaluation shall consider impacts of GAC replacement activities on SWIFT AWT throughput.
UV Disinfection	2	1	
SWIFT Water Pumping	2	1	
SWIFT Recharge Wells	N/A	2 (1 well in backflush and 1 well under rehabilitation)	

V Solids Handling Design and Operation:

- A. The evaluation of new solids handling facilities should consider alternative and multiple methods and backup plans to provide for flexibility and contingencies in case of process failure or new regulatory requirements. The design and operation of solids handling facilities should be in accordance with all provisions of the approved SCAT Regulations. Solids handling design and operation should also comply with the requirements of the 40 CFR Part 503, MACT 129, and Title V regulations.
- B. Design Life – The design life for various elements of solids handling facilities should be greater than or equal to the following:
 - 1. Structures: 50 years
 - 2. Piping and Conveyance: 50 years
 - 3. Mechanical Equipment: 20 years
 - 4. Electrical Power Equipment: 20 years
 - 5. Instrumentation and Control Equipment: 5 to 10 years
- C. Solids Capacity – The solids capacity for solids handling unit processes should be based on the following criteria:
 - 1. Plant Solids Capacity – The plant solids capacity of the overall solids handling facilities should be based on solids production at maximum monthly flow and load.
 - 2. Process Solids Capacity – The process solids capacity for individual solids handling unit processes including recycle loadings and peak loadings (such as peak weekly loadings or peak hourly loadings) should be as recommended by the design engineer.

3. Limiting Solids Capacity – The limiting solids capacity of the overall solids handling facilities should be based on the individual solids handling unit process having the lowest monthly solids capacity (i.e. the bottleneck).

Note: Observations on loadings and capacity of solids handling unit processes based on HRSD analysis and experience are as follows:

- Peak daily loadings are buffered (absorbed) by peak weekly loadings.
- Incinerator capacity is related as follows:

Peak Daily Capacity	= Equipment Rated Max Capacity
Peak Weekly Capacity	d. ~ Peak Daily Capacity due to buffering capacity = Equipment Rated Max. Capacity
Max Monthly Capacity	= 85% x Peak Weekly Capacity = 85% x Equipment Rated Max Capacity
Avg Monthly Capacity	= 85% x Max Monthly Capacity = 85% x 85% x Peak Weekly Capacity = 72% x Peak Weekly Capacity = 72% x Equipment Rated Max Capacity

- D. Design Loadings – The design loadings for solids handling unit processes are to be as recommended by the design engineer. The design loadings should be based on historical records, field sampling, or similar experience. The design loadings should include the impacts of septage discharge, chemical addition, and solids from other plants.
- E. Design For Initial Plant Startup – The design for initial plant startup should provide for efficient and economical operation of sewage treatment unit processes without problems caused by oversized tanks and equipment if low flows are expected during early years of operation. The design for initial plant startup may incorporate:
 1. Sufficient turndown capability.
 2. Additional smaller initial equipment to be operated only at lower flows.
 3. Multiple smaller initial equipment to be operated together at higher flows.

- F. Intermittent Operation – The intermittent operation of solids handling unit processes should be evaluated carefully to determine the impacts on other sewage treatment and solids handling unit processes and operations at both initial plant startup and design loadings. A plan for intermittent operations, if applicable, should be developed by HRSD and forwarded to the design engineer early in the design process.
- G. Impact On Sewage Treatment – The impact of solids handling unit processes on other sewage treatment unit processes and operations should be evaluated carefully at both initial plant startup and design loadings. Such impacts from solids handling may be detrimental to performance of sewage treatment unit processes or operating efficiency of facilities. The evaluation should consider factors such as:
1. Initial and design loadings
 2. Size of equipment and turndown capability
 3. Intermittent operation and hours of operation
 4. Recycle load impact on unit processes
 5. Interdependent onsite and offsite unit processes and operations
- H. Reliability and Redundancy – The reliability and redundancy of solids handling unit processes should be based on operating with the largest unit out of service. The reliability and redundancy of major solids handling equipment should be based on having a spare unit of the largest size. Verify the design complies with the SCAT Regulations.
- I. Equipment Selection – The current approved list of sole-source equipment can be found on HRSD’s SharePoint under Finance/Sole Source/COMMISSION APPROVED SOLE SOURCE ITEMS. Users without SharePoint access may request this document by contacting the Engineering Department.
- J. Minimum Requirements:

Solids Handling Unit Process	Min. No. of Units Installed	No. of Units Out of Service	Comments
Holding Tanks			
Storage	1 minimum, 2 preferred	1	Need to evaluate mixing requirements. Consider Confined Space Entry Permit requirements when designing access for cleaning and inspection.

Solids Handling Unit Process	Min. No. of Units Installed	No. of Units Out of Service	Comments
Day	1 minimum, 2 preferred	1	Provide odor scrubbing of the Holding Tanks.
Blend	1 minimum, 2 preferred	1	
Thickeners			
Gravity	2 sized for design loadings	1	Provide VFD/pump system turndown capability or smaller pumps for low flow requirements at initial plant startup with provisions to replace smaller pumps as plant expands.
Flotation	2 sized for design loadings w/ largest unit out of service	1	
Gravity Belt	2 sized for design loadings w/ largest unit out of service	1	
Thickened Solids Pumps	1 dedicated pump per unit with one spare pump where applicable	1	
Hopper	1	0	
Anaerobic Digesters			
Primary	2 sized for design loadings w/ largest unit out of service to meet Class B requirements	1	Requires 6 months to clean and repair digester. Both primary and secondary digesters shall be dual-purpose.
Secondary	1 sized for design loadings	1	Consider alternate gas storage on a case-by-case basis. Both primary and secondary digesters shall be dual-purpose.
2 Stage			

Solids Handling Unit Process	Min. No. of Units Installed	No. of Units Out of Service	Comments
Acid Phase	2 sized for design loadings w/ one unit out of service	1	Avoid P-traps on drawoffs due to gas/liquid binding.
Gas Phase	2 sized for design loadings w/ one unit out of service	1	
Pumps	1 dedicated pump per unit with one spare pump per every two units	1	
Heat Exchangers	2	1	Shell and tube.
Foam Control	-	-	Consider foam control measures
Dewatering			
Belt Filter Press	2 sized for design loadings w/ one unit out of service	1	Provide 1 spare uninstalled rotating assembly or 1 additional installed centrifuge. Requires 6 months for outside repair of centrifuge. Provide turndown capability or smaller pumps for low flow requirements at initial plant startup with provisions to replace smaller pumps as plant expands. Provide grinder ahead of each pump. Design system to be flexible for discharge into any / all hoppers. Provide useable hopper volume to match operational and process requirements. Account for working volume lost to angle of repose of dewatered solids.
Centrifuge	2 sized for design loadings w/ one unit out of service	1	
Pumps	1 pump per unit	1	
Hopper	2	1	
Biosolids Receiving Facility			

Solids Handling Unit Process	Min. No. of Units Installed	No. of Units Out of Service	Comments
Loading Hopper	2 sized for usable volume to hold a minimum of 60 cy each	1	Design system to be flexible for discharge into any / all hoppers. Provide usable hopper volume to match operational and process requirements at both the loading and receiving plants. Account for working volume lost to angle of repose of dewatered solids.
Receiving Hopper	2 sized for usable volume to hold a minimum of 60 cy each	1	Provide usable hopper volume to match operational and process requirements at both the loading and receiving plants. Provide for unloading from different types of trucks where possible. Account for working volume lost to angle of repose of dewatered solids.
Pumps	1 dedicated pump per unit with one spare pump	1	Provide pump range and turndown capability to match operational and process requirements at both the loading and receiving plants
Incinerators			
Fluidized Bed	2 sized for design loadings w/ largest unit out of service	1	Provide for MACT 129 requirements.
Polymer Systems			
Pumps	1 dedicated pump per unit with 1 spare pump	1	Provide VFD/pump system turndown capability or smaller pumps for low flow requirements at initial plant startup with provisions to replace smaller pumps as plant expands.

VI Access to Unit Processes and Equipment

- A. Provide access into enclosed and partially enclosed tanks, channels, and other structures to perform required inspection and maintenance. Design access points to minimize the impact on confined space entry through the use of gates, removable handrail sections, hatches with built in fall protection, anchor points, etc. Provide ground level access for above ground tanks.
- B. Provide permanent stairs, ladders, or other assemblies to access tanks, buildings, structures, equipment, valves, components, etc. in accordance

with OSHA regulations. Provide landings with handrail systems at the top and intermediate (as required) elevations of access assemblies. For ladder systems, elevate the first rung approximately 12-inches from the top-of-landing. Do not use Fiberglass Reinforced Plastic (FRP).

- C. Provide elevated walkways with handrails in accordance with OSHA requirements to access multiple tanks and/or structures in close proximity to each other. The minimum width of walkways shall be four (4) feet.
- D. Provide isolation valves upstream of all devices and appurtenances to allow for maintenance or removal. Provide isolation valves from other tanks that are commonly piped together. Provide manway access into the tank for maintenance and internal inspections.
- E. Refer to Section 22 HRSD Safety Standards within this manual for additional requirements.
- F. Provide adequate clearance and access at SWIFT recharge well facilities to allow for crane access for pump and pump column removal and installation, well redevelopment and testing and lay down area for pump column pipes and shafts adjacent to recharge well facility. Consideration shall also be given for providing lay down for well construction and space for temporary chemical storage needed for rehabilitation events.
- G. Submit equipment removal plan for all major process equipment at 60% and 100% submittal stages.

VII Sampling

- A. Sampling is required for process monitoring and control and regulatory reporting. Sampling must be representative and reliable.
- B. Sampling hatches shall be provided at designated sampling locations. All sample points shall be provided with 120V outlet connections. Raw influent and final effluent sample points shall be provided with a flow signal.
- C. Sampling points are to be planned, designed, and designated for all process flows and other samples routinely monitored. Sampling points are to provide representative samples under all operating conditions. In general, sampling points are:
 - 1. Located to include or exclude recycle streams as appropriate.
 - 2. Well mixed to avoid solids separation.
 - 3. Representative when process units are taken out of service.

4. Easily accessible for sampling or maintenance.
- D. Provide automatic samplers. Provide connections and appurtenances for automatic samplers. Provide for manual sampling in the event of failure of the automatic sampling equipment.
- E. Automatic Samplers:
1. Provide “composite-only” or “sequential/composite” samplers designed for outdoor/corrosive environments and manufactured with an exterior shell made of UV resistant fiberglass. Enclosures shall be refrigerated and heated to control temperatures inside the unit. Place samplers on housekeeping pads.
 2. Provide for external inputs for flow pacing and local receptacles for power.
 3. Coordinate with HRSD Technical Services Division to provide a bracket and pole for support of the sample tubing, where appropriate.
 4. Provide for training of the plant staff for this piece of equipment. The training is to be included with the purchase price and/or construction contract.
 5. Do not locate samplers in a classified or confined space.
- F. Sample points for ozonated water, including sample streams for analyzers, include full enclosed drain piping systems that operate under a partial vacuum to limit safety hazards due to ozone off gassing.
- G. Piping for sensors and sample outlets used for automatic process control shall be located as close as practical to the sample draw-off point in the process to minimize ozone residual decay in the sample piping.
- H. Instrumentation related to SWIFT AWT shall have dedicated sample piping provided to each instrument (i.e. instruments shall not be fed from a common sample header). Flow and pressure control and measurement equipment shall be provided as required to meet the requirements for each instrument.

VIII Chemical Containment

- A. Provide a negative slope (minimum 1/8 inch per foot) on all floors to a sump or drain.
- B. Select valves, piping, supports, and sump pump materials to be resistant to chemicals stored.

- C. Generally, a sump and pump are preferred over a drain system. Sumps to be recessed to completely drain tank floor.
- D. No equipment inside containment area – limit to piping and appurtenances. All tank instrument read-outs are to be located outside of the containment. All pump shutdown HOAs are to be located outside of the containment. If equipment must be located inside containment, locate above expected elevation of contained liquid. All piping is to be located above expected elevation of contained liquid.
- E. Size containment areas to meet local building code. At a minimum, provide storage volume of 110% of the largest tank.
- F. Minimize the installation of valves, electrical conduit, and heat trace systems within containment areas.
- G. Provide for potable or non-potable water for cleaning of the containment areas. For hose connections, provide male polyethylene camlock connections with caps.
- H. Draining chemical containment systems shall be initiated manually to ensure that chemicals are not accidentally discharged to the storm drain or plant drain system.
- I. Draining chemical containment systems shall be initiated manually to ensure that chemicals are not accidentally discharged to the storm drain or plant drain system.
- J. Provide suitable access into containment areas.
- K. Avoid piping and conduit penetrations through containment walls and floors.
- L. Locate feed pump suction piping within the containment area.
- M. Conduct a hydrostatic test of the containment area to ensure that there are no leaks.
- N. Provide appropriate waterstop material in all concrete joints.
- O. Provide close inspection of concrete workmanship and coating systems prior to the placement of tanks and other equipment.
- P. Provide local high level alarm for containment sump that is also capable of being displayed on plant DCS.

IX Chemical Feed Systems

A. General

1. Fill Stations

- a. Provide adequate venting in the design of the chemical storage tanks and fill piping. Consider the impact of vent discharge points on equipment and personnel. Chemical suppliers often use compressed air to deliver the chemical into the storage tanks and to remove the contents of the supply hoses into the storage tanks.
- b. Provide male end quick disconnect at fill stations. A dry-break fitting is not required.
- c. Consider use of duplex strainers in parallel on fill line.
- d. Review the diameter of the quick disconnect with the plant staff to limit the possibility of contamination with other chemicals on the plant site.
- e. Provide containment to connections and fill stations and provide a drain to a proper discharge point.
- f. Provide suitable ground connection for truck unloading of flammable chemicals. Interlock fill valve permissive with ground connection.

2. Storage Tanks

- a. Review sizing criteria for the tank(s) with the plant staff. Carefully consider the number of days of storage, volume needed for dilution, the number of tanks to allow for inspection and maintenance and minimum delivery volumes. A suggested method for calculating the volume of chemical to be stored is:
 - (1) 15 day peak use at plant capacity, or
 - (2) 30 day average use at plant capacity (whichever is greater).
 - (3) For chemicals which degrade significantly with time, such as sodium hypochlorite, use a 7 day peak/15 day average demand to calculate storage volumes.
- b. Consider if level indication is needed with the tank. Ultrasonic type level indicator is preferred except for flammable applications such as methanol, for which radar is

preferred. Ultrasonic level indicators should be located in the top/center portion of the tank using a flanged connection. If vertical space is not available above the tank for installation or maintenance of the level indicator, consider the use of a differential pressure cell at the base of the tank. Refer to Section 32 - Electrical and Instrumentation in this manual for further details regarding level indicators. Provide sight glasses only if a redundant system is needed. If a sight glass is required, provide valves at both the top and bottom.

- c. Set relative elevations of tank and pumps to allow drawoff of full tank volume.
 - d. Provide storage tanks with ladders, safety cages, platforms with rails, etc. in accordance with OSHA requirements. Adjacent piping should not limit access to these ladders or critical isolation valves. Isolation valves must be connected directly to the tank. Consider consolidating piping adjacent to tanks to minimize access and maintenance problems. Proper vertical clearance is also important to access tank manways and maintain equipment located on top of these tanks.
 - e. Provide multiple manway openings for access and ventilation on tanks with volumes greater than 1,000 gallons. Consider placement of manway openings for ease of access.
 - f. Provide sloped tank bottoms to allow tanks to be completely emptied using installed drains or pumps.
 - g. Design storage tanks considering compatibility with chemicals stored and concentrations anticipated.
 - h. Permanently attach each tank's nameplate information including manufacturer, year of manufacture, working volume, empty volume, material of construction, diameter, and product designed to store.
3. Piping & Appurtenances
- a. Manifold piping, tanks, and pumps and provide valves and check valves in appropriate locations to allow maximum operational and maintenance flexibility for any tank/pump/process train combination.
 - b. Bolt critical valves directly to tank to simplify locating leaks.

- c. Provide an appropriate discharge point for pressure relief valves used for chemical feed systems. Detail or describe the ultimate discharge point if it is not adjacent to the limits of the work for the project.
 - d. Provide ventilation lines for calibration columns plumbed to appropriate ventilation discharge points.
 - e. Provide a permanent pressure gauge on the suction and discharge of each pump with gauge isolation valve.
 - f. Provide flushing connections at appropriate locations in each chemical feed system. Provide a hose connection on the suction and discharge piping manifold for flushing the system.
 - g. Design piping located under or adjacent to roadways for H-20 loading.
 - h. Overhead chemical piping should be avoided whenever possible.
 - i. Attach tracer wire to pipe and install buried utility warning tape approximately 18 inches above pipelines.
 - j. Tubing runs shall be continuous between manholes.
4. Feed Pumps
- a. Provide pumps with a calibration column (manufacturer recommended or HRSD Standard). Provide pulsation dampener, elapsed-time meter, back pressure and relief valve as recommended by the Manufacturer.
5. Flow Metering – Provide a valved bypass or other method to allow for removal and maintenance of meters without spilling large amounts of chemical or shutting down critical plant processes.
6. Operations/Maintenance/Accessibility
- a. Locate eyewash and emergency shower stations adjacent to new chemical feed systems in accordance with OSHA regulations. The location of these stations is to be designed to facilitate access with existing facilities. Review the location of existing eye wash stations to determine if these station locations are satisfactory for the new work. See the Emergency Eyewash and Showers paragraph in this Section for further information.

- b. Elevate pumps or other equipment which require regular maintenance at least two feet above the floor or access platform to facilitate maintenance. This preference should not take precedence over the hydraulic requirements of the pump.
 - c. Provide duplex unit strainers accessible for maintenance when strainers are required for chemical systems.
 - d. Provide access to items of regular use or maintenance (i.e. pump wet ends, isolation valves, etc.) without the need to enter tank containment areas whenever possible. Access to these items should also be provided with as little interference and obstructions as possible.
 - 7. Chemical Off-Gassing – Provide storage tanks with vents larger in diameter (minimum 2 to 5 times) than the fill piping. Carefully consider vent orientation and discharge to limit impacts to worker safety and corrosivity to adjacent facilities. Consider the use of scrubber systems if the discharge of the vent will negatively impact the adjacent area.
 - 8. Electrical Equipment
 - a. Refer to Section 30 - Electrical and Instrumentation in this manual for further information regarding electrical equipment used for chemical feed systems.
- B. Caustic (NaOH) Systems
 - 1. General – Caustic is primarily used by HRSD as part of the odor control process. The product is normally delivered at 50% strength and immediately diluted to a strength of 25%.
 - 2. Storage Tanks
 - a. Provide steel tanks due to the heat released during the dilution procedure. Utilize a post-weld heat treatment procedure in tank manufacturing.
 - b. Provide an automatic batch control system with a metered water source for dilution. Utilize non-potable water for dilution purposes. Provide strainer on the non-potable water source.
 - c. Provide for continuous mixing of the storage tank. The pump should be a air operated diaphragm or centrifugal type. Pump to be compatible with heat generated during

dilution. Heat tracing and insulation of the tank is not required since the chemical is diluted immediately upon delivery. Insulation and heat tracing of the non-potable water piping is required for outdoor applications.

3. Piping & Appurtenances

- a. Provide Schedule 80 CPVC. For buried locations use, piping shall be double contained, either fusion welded high-density polyethylene (HDPE) or PVC with nylon braided reinforced tubing inside a PVC jacket pipe.
- b. Minimize or eliminate threaded fittings and unions whenever possible. Use flanged connections at all fittings, valves and other appurtenances. Gasket, O-rings, and pulsation dampener material shall be EPDM.
- c. Provide metal ball valves for diameters of less than or equal to three inches and metal or fiberglass composite ball valves for diameters over three inches. Provide backpressure valves designed to consider the caustic feed pump discharge pressure range.
- d. Heat trace and insulate all outside pipework.

4. Feed Pumps

- a. Provide a minimum of two feed pumps for this application. Pumps should be positive displacement.

5. Flow Metering - Provide magnetic (Mag) type flow meters with a valved bypass for each feed point. Mag meters must be mounted so that they are measuring a full pipe and so that they do not trap gases.

C. Sodium Hypochlorite (NaOCl) Systems

1. General – Sodium hypochlorite is used in the chlorine contact tanks, in the odor control scrubbers, for filamentous control in the returned activated biosolids system, and in other locations throughout the plant. The product is normally delivered at a strength between 12 – 15%.
2. Storage Tanks
 - a. Storage tanks to be manufactured of fiberglass reinforced plastic (FRP). Material selected to be compatible with field installation of bulkhead fittings. Design flexible connection

with tank piping due to expansion / flexure at connection points.

- b. Locate storage tanks indoors or in a covered location outdoors. For indoor locations, consider carefully room ventilation to limit the corrosive fumes common from this chemical. Provide insulation for all tanks located outdoors.
- c. Provide a transfer pump for this application to move product from storage tank to storage tank. Design the system to protect the transfer pump from running dry or provide a pump that is capable of running dry without causing damage to the pump.

3. Piping & Appurtenances

- a. Design piping to feed the product in neat (undiluted) form to the final application point to eliminate scaling when mixed with non-potable water. Piping shall be rigid PVC (Schedule 80) for exposed locations and PVC braided tubing for buried locations. The tubing shall be encased in a suitable PVC conduit to limit accidental damage, to provide containment and to allow for removal of the tubing in case of a leak. Provide redundant feed for buried piping for both disinfection and odor control applications. Provide access manholes at buried piping junction points and bends. Design manhole to provide containment of the chemical. Use Weld-On 724 piping glue by IPS Corporation or approved equal. Minimize or eliminate threaded fittings and unions if possible.
- b. Isolation valves shall be of diaphragm type.
- c. Evaluate manifold venting back to storage tank.
- d. Locate pressure relief / venting back to storage tank.

4. Feed Pumps

- a. Provide a redundant pump for each application. Give careful consideration to the range of flows to be handled with this system. The feed pump system must handle both nighttime low flows and peak high flow conditions. The pumps shall be positive displacement. Provide a variable frequency drive with each disinfection and odor control metering pump.
- b. Provide isolated vent systems back to the storage tanks, flush connections at each pump and calibration column vent piping.

- c. Avoid Viton seats on ball check valves used as part of the pump assembly. HRSD has found that EPDM or teflon coated EPDM is an acceptable elastomer for this application.
 - 5. Flow Metering – Provide magnetic type flow meters with a valved bypass for each disinfection and odor control feed point.
 - 6. Operations/Maintenance/Accessibility
 - a. Consider the use of a submersible mixing unit at the disinfection application feed point.
 - b. Locate all exposed piping in areas that allow easy access for repair and which will not negatively affect adjacent equipment if a leak or spill occurs.
 - c. Due to the strong odors resulting from this chemical, scrubber system on all vents are required if storage tanks are located indoors. Leak/fume detection is required if storage tanks are located indoors. Consider room ventilation and the use of 2 speed fans to evacuate excess odors.
- D. Sodium Bisulfite (NaHSO_3) Systems
 - 1. General – Sodium bisulfite is used to dechlorinate the treated effluent prior to discharge at each plant (except for Atlantic Plant). The product is normally delivered at a strength of 38%.
 - 2. Storage Tanks - See Sodium Hypochlorite Systems in this Section for tank requirements except for the following:
 - a. Locate tanks indoors in a controlled environment due to the likelihood of this chemical freezing.
 - b. Provide tanks with insulation.
 - c. Provide a two inch diameter fill station quick disconnect. Consider use of a lockable cover on the quick disconnect.
 - d. Provide tanks with a recirculation pump to keep the product well mixed and limit crystallization at the air-liquid interface.
 - 3. Piping & Appurtenances
 - a. Provide Nylon braided reinforcement tubing in PVC. Larger piping using NPW as carrying water is not preferred.

- b. Provide all piping with heat tracing and insulation. Consider providing heat panels in-lieu of heat tracing and insulation at the feed pumps.
 - 4. Feed Pumps – See Sodium Hypochlorite Systems in this Section for pump requirements except for Viton. Viton is an acceptable material for ball check valve o-rings.
 - 5. Flow Metering - Provide magnetic type flow metering with a valved bypass for both non-potable water and sodium bisulfite service.
 - 6. Operations/Maintenance/Accessibility
 - a. Due to the strong odors resulting from this chemical:
 - (1) Scrubber systems on all vents are required.
 - (2) Leak/fume detection equipment is required.
 - (3) Carefully consider room ventilation and the use of two speed fans to evacuate excess odors.
 - b. Due to concerns with chemical freezing (<55 degrees Fahrenheit):
 - (1) HRSD will provide a large face thermometer in all sodium bisulfite areas.
 - (2) Consider temperature control alarms in all sodium bisulfite areas.
- E. Muriatic Acid (HCl) Systems - Important Note: This chemical is very dangerous and very corrosive. Pay close attention to materials and the pump/pipe arrangement for safety. Corrosion of electrical components also needs considered.
 - 1. General – Muriatic acid is used as a process chemical in some odor control systems, to clean odor control scrubbers and for other maintenance purposes. The product is normally delivered at a strength between 25% – 30%.
 - 2. Storage Tanks - Review the tank sizing criteria with plant staff. The tank volume sizing should include both process and cleaning requirements. It may be more economical to provide multiple tanks at multiple locations.

- a. Provide tanks manufactured of either FRP or HDPE. Design flexible connection with tank piping due to expansion / flexure at connection points.
 - b. Provide tank level measurement.
 - c. Provide a tank vent to an appropriate discharge point. One option for the discharge location of this vent is the odor control scrubber system duct.
 3. Piping & Appurtenances – PVC (Schedule 80) piping is acceptable. PVC braided tubing for buried locations. The tubing shall be encased in a suitable PVC conduit to limit accidental damage, to provide containment and to allow for removal of the tubing in case of a leak.
 4. Feed Pumps – Provide redundant pumps only if the chemical is used as part of the odor control process. Provide a flushing connection at each pump.
 5. Flow Metering – Provide a magnetic type flow meter with a valved bypass only if the chemical is used as part of the odor control process.
 6. Operations/Maintenance/Accessibility
 - a. Design based on a batch feed process if the chemical is used for cleaning purposes only.
 - b. Minimize the use of metallic components within the tank containment area.
- F. Ferric and Ferrous Chloride/Sulfate (FeCl_3 , FeCl_2 , FeSO_4) Systems
1. General
 - a. Ferric chloride (30-33% typical delivery concentration) solution is used to remove phosphorus through precipitation at various locations in the treatment process.
 - b. Provide for ferric/ferrous to be fed to the primary, secondary clarifiers and sidestream treatment.
 - c. Dilution of this chemical is normally not required. The product is normally fed neat to the application point.
 - d. Locate proposed ferric/ferrous feed points in areas where metallic gates and/or piping will not be negatively affected.

2. Storage Tanks

- a. Provide FRP tanks due to the corrosive nature of this chemical. Provide a minimum of two tanks. Design flexible connection with tank piping due to expansion / flexure at connection points.
- b. Consider the need for continuous mixing of the storage tank. If a recirculation system is provided then a pumped system sized for 100% turnover each day should be used. The pump provided shall be a non-metallic type.
- c. Provide a level indicator for level monitoring. A sight glass on the tank is not required.
- d. Consider the use of a storage tank fill manifold with duplex basket strainer.

3. Piping & Appurtenances – Provide PVC piping and appurtenances. Valves shall be PVC true union ball type. Support systems for piping and appurtenances shall be non-metallic. For buried applications, use PVC braided tubing encased in PVC conduit to limit accidental damage, to provide containment, and to allow for replacement of the tubing in case of a leak. Install buried utility warning tape and tracer wire approximately 18 inches above all installed pipelines.

4. Feed Pumps

- a. Provide units similar to the requirements for caustic systems.

5. Flow Metering – Provide magnetic type flow meters with valved bypass.

6. Operations/Maintenance/Accessibility – Provide proper ventilation of the corrosive fumes if ferric / ferrous system is located indoors. All items within the tank containment areas and exhaust fans and any associated items shall be non-metallic. All existing metallic equipment in areas where ferric / ferrous will be located must be replaced or protected from corrosive fumes.

G. Aqua-Ammonia (NH₄OH) Systems

1. General – Aqua-Ammonia (less than 20% by weight) is used as a nutrient source to enhance biological growth or is used to control chlorine demand during periods of partial nitrification. This chemical has a high pH, which results in operational problems

similar to those found with caustic. The product is normally fed neat to the application point.

2. Storage Tanks - Provide steel or HDPE tanks. The tanks are normally under a small amount of internal pressure, which requires special attention to venting and gas relief systems. Special tank linings are not required. Containment of the tanks is required and an outdoor location for the tanks is acceptable. Provide tank level measurement. A sight glass is not required. Provide a tank vent to an appropriate discharge point. One option for the discharge location of this vent is the odor control scrubber system duct.
3. Piping & Appurtenances - Provide steel piping and appurtenances. The use of threaded fittings is acceptable. Valves shall be ball type, made of steel and rebuildable. For buried applications, use PVC braided tubing encased in PVC conduit to limit accidental damage, to provide containment, and to allow for replacement of the tubing in case of a leak. Install buried utility warning tape approximately 18 inches above all installed pipelines.
4. Feed Pumps - Provide units similar to the requirements for caustic systems. Pumps are normally operated at a constant feed rate.
5. Flow Metering - As required.

H. Polymer Systems

1. General - Polymer systems are used by HRSD for many process applications. Polymers are commonly used to increase solids concentration at thickeners, centrifuges, and for secondary clarification. Many different types of polymers are used by HRSD. Both dry and liquid systems are used at HRSD. Dry feed systems should be located in an indoor and/or controlled environment. A typical liquid polymer system is shown in Figure 31-1.

Figure 31-1: Liquid Feed Polymer System Configuration

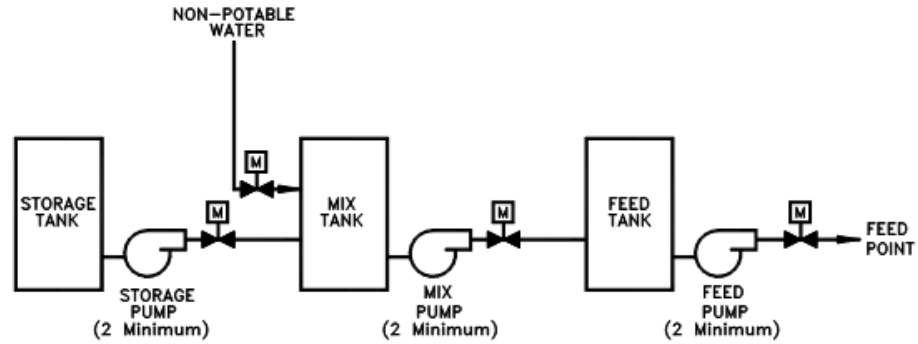

2. Storage Tank

- a. Size storage tank for the larger of a 15-day peak use or a 30-day average use. The product is stored neat. Size the mix and feed tanks according to dosage requirements and acceptable age of mix.
- b. Provide HDPE or FRP tanks with a conical bottom if possible. Provide side manway access for cleaning. Locate tanks indoors. Heat tracing and insulation are not required if the tanks are placed in an indoor and temperature-controlled environment. Design flexible connection with tank piping due to expansion / flexure at connection points.
- c. Provide a level indicator for level monitoring. A sight glass on the tank is not required. For automated sequence to control, refer to the HRSD Standard Functional Descriptions available from the appropriate Operations point of contact for the project.
- d. Provide a mechanical mixer inside the mix tank.

3. Piping & Appurtenances

- a. Provide PVC piping and appurtenances. Some polymer products tend to cause interior chemical build-up on the piping system. Provide appropriate flanged connections and unions to allow for removal and replacement. For small diameter piping (< 2 inches) provide PVC ball valves and for large diameter piping (>2 inches) provide PVC plug or ball valves.

4. Storage, Mix and Feed Pumps - Provide rotary or gear type storage pumps for liquid feed applications and progressive cavity type mix/feed pumps.

5. Flow Metering - Provide a magnetic-type flow meter and a valved bypass on the discharge of the feed pump combination.
 6. Operations/Maintenance/Accessibility – Carefully consider room ventilation. Direct tank vents to a suitable outdoor location.
- I. Methanol
1. Refer to HRSD Safety Department’s Safe Work Practice and Methanol Response Procedures Documents for this information.
- J. Oxygen (O₂) Systems
1. General – Oxygen is used to generate ozone gas. Oxygen is stored on site as a cryogenic liquid and is converted to gaseous oxygen using vaporizers. Follow NFPA and building code requirements for maintaining proper distance between storage vessels and occupied buildings. Oxygen is not compatible with hydrocarbons. Liquid oxygen unloading areas shall be free of asphalt or hydrocarbon-based expansion joints. Oxygen storage areas shall include ambient oxygen monitoring equipment, automatic shutdown interlocks, ventilation interlocks, and local and remote alarm notifications.
 2. Storage – Provide steel storage tanks. Storage tanks shall be sized such that the anticipated typical “boil-off” of oxygen is less than or equal to the anticipated 5th percentile oxygen usage rate for the treatment facility.
 3. Piping and appurtenances – provide stainless steel piping and appurtenances. A connection shall be provided for connecting a temporary liquid oxygen storage system in the event that maintenance must be performed on the installed equipment. Relief valves shall be provided as required to prevent over-pressurization of liquid oxygen between isolation valves. Cleaning of piping and components shall be per CGA G-4.1 and ASTM G93.
 4. Operations/Maintenance/Accessibility - ambient oxygen monitoring shall be provided in ozone generator rooms and other locations where high concentrations of oxygen may be present.
- K. Ozone (O₃) Generation Systems
1. General – Ozone is generated on site from oxygen gas and is applied to the water to oxidize and remove organic contaminants. Selection of ozone generators shall consider maintaining economical use of power and oxygen over the full range of expected operating conditions. Generator startup requirements

shall include tuning the generator control loops (i.e. gas flow and power) to provide stable ozone output over the entire ozone generator operating range.

2. Storage – N/A
3. Piping and appurtenances – Gaseous oxygen, ozone destruct, and ozone gas piping shall be 316L stainless steel. Piping that could come into contact with ozonated water shall be 2507 stainless steel and shall not be welded in the field. Piping gaskets shall be PTFE. Cleaning of piping and components shall be per CGA G-4.1 and ASTM G93. Ozone contactors shall be fitted with a properly sized vacuum/pressure release valve to maintain nominal vacuum conditions in the contactor while protecting the structure during filling and rapid drain-down events.
4. Operations/Maintenance/Accessibility - ambient ozone monitoring shall be provided in all facility spaces where ozone may be present (e.g. ozone generator rooms, ozone destruct rooms, sample areas). The ozone control systems shall automatically shut down interlocks, ventilation interlocks, and local and remote alarm notifications.

L. Aluminum Chlorohydrate ($\text{Al}_2(\text{OH})_5\text{Cl}$) Systems

1. General – Aluminum Chlorohydrate (ACH) is used as a coagulant to destabilize colloidal material and remove organic compounds in SWIFT influent water and develop a floc during the flocculation process for subsequent settling and removal in the sedimentation process. ACH storage and feed systems shall also be compatible with aluminum hydroxide (alum) and ferric (ferric sulfate or ferric chloride).
2. Storage – ACH tanks shall be FRP.
3. Piping and appurtenances – Yard piping shall be HDPE and routed through a secondary containment casing pipe. Exposed piping shall be Schedule 80 PVC pipe.
4. Flow metering – as required.

M. Phosphoric Acid (H_3PO_4) Systems

1. General – Phosphoric acid is used as a nutrient source for the SWIFT AWT biologically active filters. Phosphoric acid is normally delivered and fed as a 75% solution.

2. Storage – The storage volume required for phosphoric acid fed as a BAF nutrient source is normally small. Phosphoric acid can typically be received and stored in chemical totes. Chemical totes shall be installed on scales to allow for chemical inventory monitoring through DCS.
3. Piping and appurtenances - Yard piping shall be HDPE and routed through a secondary containment casing pipe. Exposed piping shall be Schedule 80 PVC pipe.

N. Hydrogen Peroxide (H₂O₂) Systems

1. General – Hydrogen peroxide (H₂O₂) is used in conjunction with ozone and/or UV to form hydroxyl radicals used for advanced oxidation of target compounds. Hydrogen peroxide can be delivered at a strength of 35% or 50%.
2. Storage – Hydrogen peroxide storage tanks shall be 316L stainless steel or HDPE.
3. Piping and appurtenances – Hydrogen peroxide piping shall be welded or flanged 316L stainless steel. Gaskets shall be expanded PTFE. Ball valves shall be used for isolation and shall be vented. Relief valves shall be provided as required to prevent over-pressurization of hydrogen peroxide between isolation valves.
4. Flow metering – as required.

X Drain Systems

- A. Consider plant drain system hydraulic capacity. A hydraulic grade line should be plotted with each new plant drain. Surcharging of gravity systems should be controlled. Design system to convey contents of the largest tank in less than 12-hours.
- B. Gravity drain systems are preferred over pumped systems for all processes except primary and BNR unit process tanks. Provide valves for isolation and throttling of each tank or process. Provide regular access points (manholes) in gravity systems and cleanouts in pumped systems. Provide ability to pump out primary and BNR unit process tanks and return to in-service unit process/tank.
- C. Grit, solids handling, and polymer process areas require special plant drain considerations due to the likelihood of plugging. Limit fittings, provide flushing connections and cleanouts, provide adequate diameter/slope of gravity drain system. Use long radius fittings.

- D. Provide trench drains for pump galleries and evaluate trench drains for containment areas. Grating to be easily removable and corrosion resistant.
- E. Provide flushing and cleaning locations with plant drain systems. If multiple processes are connected to the plant drain a method of isolation is needed to allow for effective cleaning operations.
- F. Drain systems shall be tested as described in the Pipeline portion of this Section.
- G. All concrete embedded drain inlets must be poured with a slope to the drain inlets.
- H. Provide drain located under each emergency eyewash and shower.
- I. All process tank drains are to be sump, trench, or negative slope floor drains.
- J. All process buildings are to have either trench drains to sump or at minimum one floor drain for every 500 square feet of floor area. Floor drains are to be within three feet of process equipment.
- K. Plant drains shall return upstream of influent screens.
- L. Locate drain valves for ease of access, maintenance, and replacement. Avoid buried valves where possible.

XI Emergency Eyewash and Showers

- A. Refer to Section 22 - HRSD Safety Programs for specific requirements.

XII Equipment Numbering Sequences

- A. Equipment designations shall correspond to the existing Operations Department equipment identification number (EID) system and/or asset ID and plant unit process designations. All design drawings, specifications and Operations Manuals shall incorporate the plant unit process designation. The EID numbers shall be shown on the Record Drawings. The following alpha-numeric functional coding system is used to determine the EID: Plant Abbreviation/ST or SH/ Unit process – System – Subsystem – Component

- 1. Plant Abbreviation – Letter designation for each plant as follows:

- Army Base - AB
- Atlantic - AT
- Boat Harbor - BH

Central Middlesex - CM
 Chesapeake-Elizabeth - CE
 Chincoteague - CT
 James River - JR
 King William - KW
 Lawnes Point - LP
 Middle Peninsula - MP
 Nansemond – NP
 Onancock – ON
 Urbanna - UB
 Virginia Initiative Plant - VIP
 West Point - WP
 Williamsburg - WB
 York River - YR

2. Unit Process – Letter designation as follows:

Code	Unit Process
A	Administrative Facilities
B	Plant Utilities
C	Flow Storage/Equalization
D	Preliminary Treatment
DCS	Distributed Distrubuted Control System System
E	Primary Treatment
F	Intermediate Treatment
G	Secondary Treatment
H	Sidestream Treatment
I	Tertiary Treatment
J	Disinfection
K	Effluent Pumping/Water Reclamation
L	Scum Disposal
M	Biosolids Thickening
N	Biosolids Anaerobic Digestion
O	Biosolids Heat Treatment
P	Biosolids Storage
Q	Biosolids Dewatering
R	Biosolids Incineration
S	Biosolids Composting
T	Biosolids Land Application
U	Odor Control
Z	Spare
AA	SWIFT Administrative Facilities
BB	SWIFT Plant Utilities
CC	SWIFT Flow Equalization

Code	Unit Process
DD	SWIFT Preliminary Treatment
EE	SWIFT Coagulation/Flocculation
FF	SWIFT Sedimentation
GG	SWIFT Ozonation
HH	SWIFT Biofiltration
II	SWIFT GAC Adsorption
JJ	SWIFT UV Disinfection
KK	SWIFT Water Distribution
LL	SWIFT Aquifer Recharge
MM	SWIFT Treatment Residuals

3. The System, Subsystem, and Component designations are assigned by the Maintenance Planner.

B. New equipment shall be designated using a priority sequence based on original plant's existing numbering sequence. The FIRM shall review the sequence with the plant staff early in the design stage of the project.

XIII Equipment Spare Parts

A. It is HRSD's goal to minimize the inventory of unnecessary spare parts. Review the plant's needs for spare parts and recommended special equipment/tools with HRSD prior to including these components in the contract documents.

XIV Miscellaneous Pump Items

A. Seal Water Piping

1. Use strained NPW or potable water for this application. Potable water should only be used as a backup seal water source should the NPW pumping system fail. Backflow preventer is required when potable water is used.
2. Provide manual bypass.

B. Sump Pumps

1. Sump pumps shall be designed to pass the product/chemicals in the area of the sump. If the materials of construction necessary to safely pass the product/chemical under consideration make the pump cost impractical, consider a lower cost, replaceable sump pump or manual NPW eductor system.

- C. Shaft Guards – Manufacturer shall provide shaft guards to comply with OSHA requirements. Refer to 29 CFR 1910 Subpart O Machinery and Machine Guarding. Select material of construction considering specific installation environment conditions.

XV Noise Abatement for Installed Stationary Equipment

- A. Refer to Section 22 - HRSD Safety Programs section in this manual.
- B. Consider sound attenuation in spaces that house equipment such as blowers, centrifuges, odor control fans, incinerator fans and generators.
- C. Minimize location of equipment and control devices in areas with significant noise levels.
- D. Design equipment installed in exterior locations such that no offsite noise nuisance will result.

XVI Non-Potable Water Systems

- A. Non-Potable Water (NPW) systems are used for certain plant treatment processes, cleaning and for flushing systems on some equipment seals. The NPW system should be designed to provide needed pressures at all locations of the plant while meeting regular water demands. A looped piping system that is isolated at each process should be provided.
- B. Provide automatic cleaning strainers on the discharge of pumping systems.
- C. Provide strainers at each major plant process or critical delivery point.
- D. Consider how the NPW pumping system could be expanded in the future. Provide redundant NPW pump and/or an emergency pump connection.
- E. NPW piping shall be ductile iron, PVC or HDPE.
- F. Provide NPW hydrants at each process location. NPW hydrants shall be located to limit hose lengths to approximately 100 feet. Consider a quick disconnect, valve and drain in-lieu of a hydrant at process tank locations. Provide NPW hydrants with a self-draining feature to limit freeze problems.
- G. Exposed NPW systems to be painted and marked in accordance with the Miscellaneous, Painting and Coatings section of this document.
- H. NPW piping systems shall be separated from SWIFT treatment areas. SWIFT treatment areas shall be provided with potable water (PW), utility

water (UW), or SWIFT NPW water for washdown, process make up, or utility water demands.

- I. Provide minimum ¾-inch a stainless steel hose reel and washdown station for NPW or SWIFT NPW at each plant process that requires regular cleaning.

XVII Odor Control and Room Ventilation

A. General

1. The following text lists HRSD's current standards for the design of odor control facilities with respect to H₂S. A different design approach will be required when there is a significant odor concern other than H₂S. This standard addresses chemical packed towers. Consider combination bio-filter-chemical packed tower systems or carbon units when applicable.
2. Design odor control facilities to eliminate off-site nuisance odors. Odor control facilities typically include enclosing the odorous work areas and covering odorous process areas, ducting the odorous gases to scrubbers, and scrubbing the odorous gases in a two stage packed tower scrubber system. With respect to dual stage chemical packed tower scrubbers:
 - a. Initially reducing the H₂S concentration to less than 5 ppm in the first stage scrubber using only caustic to maintain a scrubber recirculation water flow pH range of 10 to 11 And not to exceed 11.5 where possible.
 - b. Achieving a first stage scrubber effluent H₂S concentration of 5 ppm or less with a maximum effluent H₂S concentration not to exceed 10 ppm.
 - c. Obtaining the remaining H₂S removal in the second stage scrubber using 6.12 gallons of hypochlorite per 1,000 cfm and sufficient caustic to maintain an optimum pH of 8.5 or greater.

NOTE: Alternative oxidant chemicals may be evaluated and utilized. Alternative chemical feed control strategy such as ORP, or continuous H₂S or chlorine gas monitors may be used. Achieving a second stage scrubber effluent H₂S concentration of 0.1 ppm and not to exceed 2 ppm.

B. Air Flow

1. Provide for sufficient air flow from enclosed work areas and covered process areas to provide adequate ventilation and odor control as appropriate. Entrance doors should be labeled with the design air changes per hour.

NOTE: Air flow for work areas occupied by personnel should be based on ventilation requirements as appropriate and/or approved by Safety. Air flow for ventilation should not be routed through odor control facilities wherever practical. Air flow for odor control in some situations can be substantially reduced by pressurizing work areas otherwise requiring only ventilation and drawing off only a portion of the ventilation air flow through the unit process openings for odor control. Air flow for odor control in other situations can be substantially reduced in a work area by using covers or hoods on process equipment. The minimum air change requirement indicated below shall be maintained.

2. Provide air flow based on the more stringent of the NFPA 820 requirements, other applicable codes, or the following design criteria:
 - a. Air Changes - Provide for the minimum number of air changes as follows:

Type of Area	Air Changes Per Hour
Enclosed work area directly exposed to wastewater or solids with normal access by personnel <u>Examples</u> Bar Screen Room Grit Classifier Room Grit or Scum Dumpster Room Solids or Scum Thickener Room (uncovered) Solids Handling Filter Room Solids Conveyor or Hopper Room Truck Drive Through Room	12 x per hour
Enclosed work area not directly exposed to wastewater or solids with normal access by personnel <u>Examples</u> Solids Handling Centrifuge Room	6 x per hour

Type of Area	Air Changes Per Hour
<p>Enclosed access, equipment or storage area not directly exposed to wastewater or solids with normal access by personnel</p> <p><u>Examples</u> Electrical Rooms Stairwells</p>	1.5 x per hour
<p>Covered process area with extreme turbulence or H₂S levels without normal access by personnel</p> <p><u>Examples</u> Screw Pumps Grit Tanks Pre-aeration Tanks</p>	12 x per hour
<p>Covered process area directly exposed to relatively turbulent wastewater or solids without normal access by personnel</p> <p><u>Examples</u> Splitter Boxes Solids Handling Tanks (based on empty)</p>	6 x per hour
<p>Covered process area directly exposed to relatively quiescent wastewater or solids without normal access by personnel</p> <p><u>Examples</u> Non-Aerated Channels Primary Clarifiers (including weirs) Anaerobic/Anoxic Tanks</p>	4 x per hour
<p>Covered process area receiving process air without normal access by personnel</p> <p><u>Examples</u> Aerated Channels Aeration Tanks</p>	Max Process Air + 10%

Type of Area	Air Changes Per Hour
<p>Enclosed work area where personnel could encounter oxygen or ozone gas</p> <p><u>Examples</u> Ozone generator room Ozone sample gallery Ozone destruct room</p>	<p>6 x per hour under typical operating conditions</p> <p>12 x per hour if oxygen or ozone is detected above the alarm value.</p>

- b. Face Velocity - Provide for a minimum face velocity of 100 FPM for any indoor unit process opening. Provide for higher face velocities for outdoor unit process openings to counteract wind affects as appropriate. Prevent backdraft of toxic levels into enclosed work areas. Ensure destruction of H₂S in scrubber based on past operating experience.

C. Public Acceptance, Nuisance Prevention and Odor Control – Public acceptance, nuisance prevention and odor control for treatment plants must be achieved for HRSD to provide quality service. Adverse impacts to nearby neighbors and communities from treatment plant facilities must be prevented, eliminated or minimized to the extent practical.

- 1. Public acceptance is critical for HRSD to build new treatment plant facilities to serve the public. Public acceptance should be paramount when siting, designing and operating facilities, and these activities should be coordinated with the public information program to promote public acceptance. Nuisance prevention is required for treatment plants to be good neighbors. HRSD’s goal is to prevent offsite nuisances. Treatment plant facilities should be planned, designed and operated to mitigate offsite nuisances from odor, noise, light, traffic or other causes to the extent practical. Buffer areas should be in accordance with all provisions of the approved SCAT Regulations but in all cases should be at least 300 feet from any potentially nuisance process unit or activity to the property line for new treatment plants. The planning and design of facilities should also account for the inevitable encroachment of new residential, commercial, and industrial neighbors on any nearby developable land.

D. Scrubber Equipment

1. Provide for a scrubber train consisting of two packed tower scrubbers connected in series per the following:

Packing detention time	1.3 – 1.6 seconds
Packing depth	10 feet
Packing type	As appropriate
Packing support	Grating or gas injection plate
Recirculation liquid to air ratio	15 – 20 gpm/1,000 cfm
Liquid distribution	Single nozzle if less than 9 foot diameter, or a weir distribution system or multiple nozzle system with nine or more nozzles if greater than nine foot diameter.
Blowdown rate	To be provided
Mist eliminator	Use mesh or media type

2. Provide for one or more individual scrubber trains connected and isolated in parallel to accommodate the required size as appropriate.
3. Provide for one additional fully equipped standby scrubber train including induced draft fan connected and isolated in parallel with the other scrubber train(s).
4. Provide for each scrubber train a discharge stack designed to discharge at sufficient height to disperse the emissions and eliminate offsite odors. Consider adding a directional stack piece on the stack discharge to direct air flow and air flow noise away from populated areas.

E. Chemical Feed

1. Provide for all scrubbers to be fed with caustic and sodium hypochlorite.
2. Provide for chemical feed rates per the following:
 - a. A minimum caustic feed to first stage scrubber of 3 pounds NaOH per pound of H₂S to obtain an average effluent H₂S concentration of 5 ppm and maximum of 10 PPM.
 - b. Sodium hypochlorite feed to the first stage scrubber (as an alternative sodium hypochlorite feed point in lieu of the second stage scrubber) of 2.1 gallons NaOCl per pound of

H₂S removed to obtain a maximum effluent H₂S concentration of 5 ppm.

- c. Sodium hypochlorite feed to the second stage scrubber of 6.12 gallons of NaOCl/1,000 cfm and sufficient caustic to maintain a pH of 9.5 in the scrubber recirculation water flow or greater at a maximum influent H₂S concentration of 5 ppm.
3. Provide for new caustic feed and storage facilities located separately or at the existing caustic feed facilities utilizing the available caustic storage facilities to the extent possible. Size the caustic storage tanks for a minimum of 15-days peak use or 30-days average use.
4. Evaluate the use of existing hypochlorite storage facilities to the extent possible. Size sodium hypochlorite for a minimum 15-days storage at the average design feed rate.
5. Provide for at least one caustic feed pump for each operating scrubber with one standby caustic feed pump for the overall scrubber system.
6. Provide for at least one sodium hypochlorite pump for each operating two stage scrubber system and one standby hypochlorite pump for the overall scrubber system.
7. Provide for automatic pH control of caustic feed for each scrubber using pH monitoring of the scrubber overflow. Also provide for automatic control of caustic feed to the first stage scrubber using continuous H₂S monitors.
8. Provide for automatic control of sodium hypochlorite feed to each second stage scrubber for H₂S removal using ORP or continuous sulfide monitors.
9. Provide for adding chemicals to the suction or discharge side of the recirculation pump and/or to the scrubber sump if baffled to prevent short circuiting. Ensure chemicals are added downstream from the pH meter where feasible.
10. Provide for separate metering of caustic solution, sodium hypochlorite solution and makeup water flows to each scrubber.
11. Provide muratic acid storage, pumping and containment for scrubber cleaning. Provide for manual control of acid feed.

- a. If acid is fed to the first stage scrubber to decrease pH, then acid storage and containment should be sized appropriately. Automatic acid feed based on pH should be provided.
- F. Coatings - Provide for coating protection for covered process areas to prevent corrosion due to H₂S attack per the following and refer to the Coatings Manual.
 1. Provide coatings on all exposed interior surfaces of covered process areas and extend coatings to one foot below the low water surface or to an appropriate termination point.
 2. Consider life cycle cost in the selection of coatings.
 3. For areas which cannot be isolated and accessed for coatings maintenance using existing plant valving (i.e. splitter boxes, flow distribution chambers/channels, etc.) consider the cost of over pumping in determining life cycle costs. Stronger consideration will be given to anticipated life of the coatings in these areas.
- G. Duct Work
 1. All duct shall be manufactured of fiberglass reinforced plastic (FRP). All FRP shall have UV protection. Ductwork in most cases should be elevated above ground. Consider access and maintenance of adjacent equipment when locating ductwork.
 2. Odorous air is almost always very humid. Provide a drain system at low points in ductwork. Extend drain piping to existing drains or tanks. Drains must have a P-trap sufficient to overcome system vacuum.
- H. Room Ventilation (As related to Odor Control)
 1. See Air Flow at the beginning of this Section for air flow requirements.
 2. Review with plant staff the use of timers, manual overrides and switches for the proposed ventilation system in each area.
 3. Provide the maximum distance possible in each building space between intake and exhaust locations to limit short-circuiting of air flow.
 4. Utilize non-corrosive hardware for all exhaust fans and vent assemblies.
 5. Design screened louvers to be accessible for maintenance and to

limit rainwater from entering the building space.

XVIII Pipe Insulation and Heat Tracing

- A. Provide a fiberglass, PVC jacketed insulation system.
- B. Provide indicator (on/off) lights on all heat tracing systems.
- C. Provide for piping insulation jacket to be color coded and/or stenciled in accordance with HRSD's Piping Identification and Color Code included in the "Miscellaneous" section of this manual.
- D. Provide junction boxes/plugs on heat tracing systems to allow for removal of fittings, valves, etc.
- E. For new construction, provide power source with appropriate equipment. For retrofits and improvements, indicate a location for the power feed to the proposed heat tracing system and verify that the existing power panel is suited for this application.
- F. Refer to Section 32 - Electrical and Instrumentation in this manual for further information regarding electrical equipment and requirements.

XIX Primary and Secondary Clarifiers

- A. Provide circular clarifiers with center feed, peripheral weir layout.
- B. The following system components should also be included in new or modified secondary clarifiers:
 - 1. Provide design which assures a watertight gearbox.
 - 2. Provide a biosolids withdrawal system that is compatible with flow proportion RAS flow and does not require manual adjustment when flow volume or concentration changes. A suction plenum or Tow-Bro type biosolids collection system is preferred. Organ pipe drawoff systems are not acceptable.
 - 3. All components shall be stainless steel.
 - 4. Provide a modular drive system that can be repaired or replaced without dismantling the clarifier structure.
 - 5. Provide fiberglass clarifier weir covers designed to allow cleaning of weir and launder channels, or provide weir covers to deter algae growth.
 - 6. Provide a gravity drain system if possible. Consider a method to fully drain clarifier to allow for inspection and cleaning. Refer to

drain system section [insert section number] for additional information.

7. Provide adequate NPW system to meet cleaning and tank filling needs.
8. Provide positive control of RAS flow from each individual clarifier.
9. Provide full diameter scum well and pump. Provide cleanouts.

XX Process Air Piping

- A. Process air piping shall be either stainless steel or welded carbon steel. Process air piping shall be placed in the following locations:
 1. Above grade
 2. Direct bury with a proper coating and/or cathodic protection system. Avoid buried pipe whenever possible.
- B. Thermal expansion and contraction must be carefully considered with this piping system. Methods for support and/or restraint must be coordinated with the possibility of thermal expansion and contraction.

XXI Process Flow Splitting

- A. Perform a hydraulic analysis to verify that adequate flow splitting occurs for the following conditions:
 1. Daily Average Flows – existing and at the rated plant capacity.
 2. Diurnal Flows – average daily minimum and maximum at existing flow conditions.
 3. Unit out of Service – when multiple units are included in the design, consider the impacts of the largest unit out of service.
 - a. Provide for flow balancing between multiple units using low velocity channels where feasible. If channels are not possible, provide valves designed for throttling and/or adjustable gates/weirs.
 - b. Buried valves designed for throttling shall be located in a vault and sized to allow for access and future removal of the equipment.
 - c. Review with HRSD the anticipated frequency of flow balancing and the value/cost of providing remote monitoring and control.

XXII Scum Handling, Piping and Pumping

- A. The type of scum received depends upon the grease loads of the collection system, type of screen equipment, and grease from septage receiving. Scum is any combination of: water, grease, plastics, rags, floatables, and foam (from the biological process). Some general design guidelines and considerations are listed below to limit scum handling problems:
1. Design preliminary treatment to remove plastics, rags, etc that cause scum conveyance issues. Screening equipment such as band screens and step screens are appropriate.
 2. Eliminate scum pits. The use of pits results in a batch process that tends to plug pipes, pumps and appurtenances.
 3. Automate the handling process to allow for a direct feed system to the scum concentrator and/or incinerator.
 4. Consider the reduction or elimination of scum gravity collection systems.
 5. Locate the scum concentrator to minimize piping and materials handling.
 6. If the WWTP uses bar screens, expect plastics and rags at every collection source; provide grinders at each source.
- B. Scum piping is to be 4 inch minimum between the collection source and a concentrator. Provide clean outs at all bends and Y's. Yard cleanouts are to be Y connections at a maximum every 50 feet.
- C. Scum grinding is to be as close to the source as possible followed by scum pumping. Scum grinder must be replete with full bypassing capability to accommodate the grinder removal for maintenance.
- D. Scum pumping shall be provided using screw, centrifugal or progressive cavity type units. Non-clogging pumps are not substitutes for grinders.
- E. When using a well or decanting tank, consider the use of a continuously mixed system and/or heated system to limit the likelihood of the scum from separating or plugging handling equipment.
- F. Provide an NPW flush system at the source of the scum collection.
- G. Scum concentrators are to have a minimum retention time of 20 minutes. Scum concentrator hoppers are to be heated.

- H. Scum piping after concentration is to be heat traced. Hot water, steam and NPW flushing connections are to be provided at the point of origination and destination. All downstream piping is to use sweeps with Y cleanout connections at a maximum every 50 feet.
- I. Scum in the form of foam collected from the biological process is to have provisions for hypochlorite addition and NPW sprays to collapse the foam and allow conveyance.
- J. Disposal: Scum may be processed to a landfill after adding an appropriate amendment for the paint filter test (sand, rags, grit, etc.), or it may be incinerated as long as operational impacts are observed as well as adherence to 503 and MACT 129 regulations.

XXIII Grit, Septage and Grease, and Biosolids – Grit, septage and grease, and foreign biosolids require special consideration and facilities to handle these materials effectively, minimize required labor for operations and maintenance, and prevent nuisance conditions. Inadequate facilities for handling these materials can have a significant adverse impact on overall treatment plant operations and costs.

- A. Grit:
 - 1. Grit handling facilities should be sized based on the characteristics and quantity of grit at the individual treatment plant. Examine the impact of grit on the existing WWTP.
 - 2. Consider raw influent and plant influent grit characterization sampling to determine grit loading on the plant during dry and wet weather events.
 - 3. Review collection system infiltration as well as velocities during dry and wet weather to determine grit slug loads. Use 1 ft/sec rule for deposition of grit and 3 – 5 ft/sec rule for re-suspension of grit. Review diurnal flow patterns for the number of grit removal units during wet weather events. Grit removal units such as detritors, head cells, and vortex are to be considered at a minimum. Consider two times the recommended number of vortex units for peak wet weather events. Grit channels are not to be considered.
 - 4. Individual components including separators, cyclones, classifiers, pumps and piping should be sized for peak grit loadings occurring during storm flow conditions which may be significantly higher than the corresponding peak flows. Consider vertical cyclones over angled installations to minimize recycle loads on the plant.
 - 5. Provide plug style valves fitted with grit seals. No epoxy-coated plug valves. Provide for easy flushing with NPW at all elbows and tees.

6. Grit handling facilities and grit containers should be located inside enclosed buildings with odor control. Grit containers should be designed for leveling and/or easy moving without significant operator attention. Provide plastic curtains around the dumpsters to minimize the impact of splatter. Provide 6-inch diameter at rollup doors to protect the door frames during grit container removal. Provide bollards or similar for stops upon placement of grit containers. Provide floor drains under grit containers with clean outs.
- B. Septage and grease handling facilities should be designed to remove/process these materials and minimize adverse impact on sewage treatment operations in an unattended mode. The addition of septage or FOG receiving may be based on beneficial use of these products in the treatment process, or by lack of other receiving options within a reasonable transport distance. Septage facilities shall be designed to unload a 6,000 gallon septage or grease truck within 15 to 20 minute period. Storage/equalization capacity for the facility shall be provided and based on historical data for peak week average of the total daily discharge volume. Preliminary screening, such as rock traps, grinders, package type screening systems, etc. shall be provided to prevent debris from impacting transport and pumping of discharge through pipes and pumps. The combined discharge will be equalized and pumped back to the influent channel downstream of the raw influent sampling point, but before the plant screens. Facilities shall be capable of passing grit and grease. Septage and grease handling facilities and grease and grit containers should be located inside enclosed buildings with odor control. Grease only facilities should be designed to collect, transport, concentrate, load grease containers or otherwise dispose of the grease. Receiving stations shall be integrated with Scale Automation and DCS systems for monitoring and control.

A washdown area with containment should be provided for each discharge location. Each discharge station shall include a trench drain with a sump located below the discharge station connection. The discharge station connection shall include a 12 inch section of clear tubing and have a single lever operated agricultural knife gate valve for isolation. All connections shall use camlock fittings. Trench drain should span the entire discharge area and slope from both sides to the center sump area. Trench drain grating shall support H₂O loading. Trench drain to be a minimum depth of 12 inches and 12 inches wide with a 6% negative slope to sump intersection. Sump area shall be 4'0 x 4'0 x 1.5'. Sump shall include float operated grinder style sump pump that discharges to equalization tank, unless equalization is below grade. All connections to sump pump shall be camlock fittings.

All equalization tanks shall be accessible and unobstructed to allow cleanout using vac truck for cleaning operations. Provide sloped bottom and center collection point to allow for complete emptying. If equalization tank is above grade, a 36-inch diameter side manway shall be provided on all tanks and integral tank wash down system shall be provided.

- C. Dewatered solids handling facilities shall include both receiving and loading facilities based on plants specific or HRSD solids management strategy. Dewatered solids handling facilities should be sized based on the volume/characteristics of biosolids to be handled at the individual treatment plant. The time period required to load or unload a truck or empty a receiving hopper shall be balanced to support both operational and process requirements at the loading and receiving facilities. Dewatered solids receiving facilities at incinerator plants should be designed to accept and hold multiple full truck loads and feed the incinerator in a batch process with or without blending with the treatment plant's own biosolids. Dewatered solids receiving facilities should be designed to accept various truck designs on a case by case basis.

XXIV Site Lighting

- A. Review the footprint of each light to ensure that the proper areas are being lit and that no off-site nuisance light will result. For all new lighting, consider use of high efficient LEDs.
- B. Provide task lighting (low level) in-lieu of high mast lighting in areas where nighttime operation and maintenance efforts are required.
- C. Use quick-strike capabilities when high-intensity discharge lights are used to allow for immediate access to the area being illuminated. Consider LED systems.
- D. Design high-mast lights to meet minimum lighting level requirements. Refer to Section 22 - HRSD Safety Programs in the manual for specific lighting levels. High-mast lights to operate on photocells. Provide on/off switches for additional lighting on and around individual process tanks.
- E. Refer to Section 32 - Electrical and Instrumentation in this manual for further information regarding site lighting equipment and requirements.

XXV Slide and Sluice Gates

- A. Gates to be fabricated of cast iron, stainless steel, or co-plastic and compatible with process flow and up/downstream chemical discharge.
- B. Gates to be provided with double-seated configuration or single seat if flow is limited to one direction.

- C. Provide electric operators on gates.
- D. Provide redundant gates, stop log channel or other method to isolate gate for maintenance or replacement.
- E. Provide for means of access and maintenance platforms at gate actuators, if the working elevation is greater than 5 feet.
- F. Gate should be installed so that they can be removed vertically without impedance of overhead structures.

XXVI Solids Piping

- A. Piping should be stainless steel, HDPE or ductile iron.
- B. Provide an NPW flush system.
- C. Pumps for centrifuge or thickener feed to be progressive cavity, lobe, or centrifugal with variable frequency drives. Consider the use of grinders, solids screens, or integral pump grinding as part of the pumping system design.
- D. Pumps for return and waste biosolids to be centrifugal with variable frequency drives.
- E. Return activated solids (RAS) systems should be designed so that multiple pumps can be used to withdraw biosolids from different clarifiers. Operating flexibility and sufficient monitoring/control is critical. The system should be designed to allow for the balancing of solids within each clarifier. An accurate and reliable metering system is critical to the proper operation of this process. Consider flow and mass metering.

XXVII Travel Path (Walkway) Alignment

- A. Provide walkways in heavily traveled locations (i.e. adjacent to Administration Buildings).
- B. Locate walkways for ease of access of plant staff to daily sampling points. Provide ramps for bicycle and cart access.
- C. Provide drainage pipes under walkways in lieu of lowering sidewalk elevations at drainage swales.
- D. Provide elevated walkways to connect above-grade unit process tanks.

XXVIII Yard Piping

- A. Each piping system should be carefully evaluated for above ground use, buried use and the product being conveyed. Select pipe material taking

into consideration the soil conditions and corrosivity. Provide pipe protection as appropriate. The following materials of construction and design features should be considered:

1. Ductile iron – Consider internal and external corrosion. Refer to Section 24 - Pipeline and Appurtenances in this manual for further information.
 2. Reinforced concrete pipe (RCP) and reinforced concrete cylinder pipe (RCCP) - Provide plastic liner on piping upstream of aeration basins (T-lock by Ameron, LinaBond or approved equal).
 3. Welded steel (WSP)– Consider internal and external corrosion. Refer to Section 24 – Pipeline and Appurtenances in this standards manual for further information.
 4. High Density Polyethylene (HDPE)
 5. Fiber Reinforced Plastic (FRP)
- B. At locations of high flow consider the use of concrete channels in-lieu of yard piping. Provide internal coating or liner systems as required.
- C. Consider the ability to access, inspect and maintain yard piping after construction is complete. Consider the use of access manways, isolation gates and valves to enter these pipelines.

XXIX Functional Descriptions

- A. HRSD has developed functional descriptions for each unit process. HRSD's goal is to standardize the processes at the various plants as much as possible. Hence, the FIRM shall use the HRSD Functional Descriptions as a foundation for developing the P&IDs and functional descriptions for all projects. If a functional description is developed for a new process the FIRM shall follow the format of the HRSD functional descriptions.

The most up to date functional descriptions should be requested by the FIRM at the start of a new project.

XXX Operational Technical Information System (OTIS)

- A. HRSD has developed a web based Operational Technical Information System that serves as a repository for plant information and is the basis for the Operational and Maintenance Manual that is submitted to the State. HRSD's goal is to standardize the OTIS structure and layout for each treatment plant as much as possible. The FIRM shall provide HRSD with requested information to populate OTIS. The FIRM shall populate

template provided by HRSD for review and acceptance. The OTIS is accessed through HRSD's SharePoint site.

XXXI Equipment Startup, Training, and Turnover

- A. Refer to Master Specification "01650 – Facility and System Startup System Startup" in Section 40 of this manual.

XXXII Flow Metering

- A. Provide flow metering for the final effluent regulatory flow. Locate meter to read a true final effluent flowrate. There shall be no recycles to subtract.
- B. Provide a Parshall flume and manual verification scale to confirm instrumentation calibration.
- C. Verify downstream hydraulics do not impact meter reading at a 10-year peak hourly flow.

End of Section