

NOTES:

1. FL X PE NIPPLE WITH MEGA-LUG.
2. PE X PE NIPPLES WITH MEGA-LUGS. THE USE OF FOSTER ADAPTERS WILL BE CONSIDERED ON A CASE-BY-CASE BASIS BY HRSD.
3. JURISDICTION VALVE.
 - a. JURISDICTION VALVE TO BE SAME SIZE AS EXISTING HRSD VALVE.
 - b. ECCENTRIC REDUCERS TO BE INSTALLED AS NEEDED AFTER JURISDICTION VALVE.
 - c. HRSD PIPELINES THAT HAVE CORROSION PROTECTION IN PLACE WILL REQUIRE AN ISOLATION COUPLING. CONTACT THE HRSD ENGINEER FOR DETAILS.

NOT TO SCALE



STANDARD DESIGN DETAIL

CONNECTION TO EXISTING HRSD VALVE WITH
NO POTENTIAL FOR ADDITIONAL DEVELOPMENT

DRAWING NO.
300

SHEET
1 OF 1

DATE
2/2024

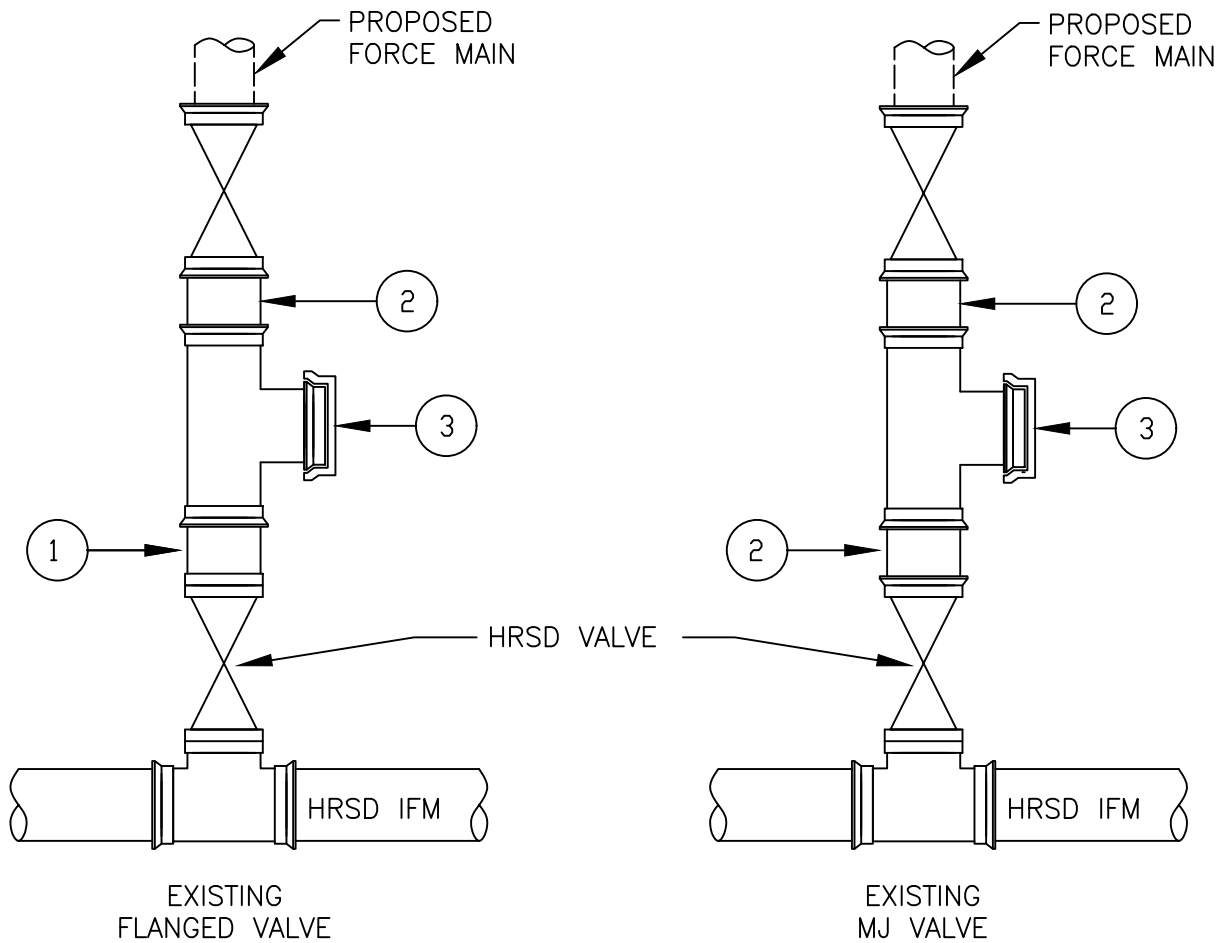

NOTES:

1. FL X PE NIPPLE WITH MEGA-LUG.
2. PE X PE NIPPLES WITH MEGA-LUGS. THE USE OF FOSTER ADAPTERS WILL BE CONSIDERED ON A CASE-BY-CASE BASIS BY HRSD.
3. MJ CAP/PLUG.
 - a. JURISDICTION TO OWN TEE AND VALVE UPSTREAM OF HRSD VALVE.
 - b. TEE AND JURISDICTION VALVE TO BE SAME SIZE AS EXISTING HRSD VALVE.
 - c. ECCENTRIC REDUCERS TO BE INSTALLED AS NEEDED AFTER JURISDICTION VALVE.
 - d. HRSD PIPELINES THAT HAVE CORROSION PROTECTION IN PLACE WILL REQUIRE AN ISOLATION COUPLING. CONTACT THE HRSD ENGINEER FOR DETAILS.

NOT TO SCALE

	STANDARD DESIGN DETAIL	DRAWING NO. 301
	CONNECTION TO EXISTING HRSD VALVE WITH FUTURE DEVELOPMENT POTENTIAL	SHEET 1 OF 1
		DATE 2/2024

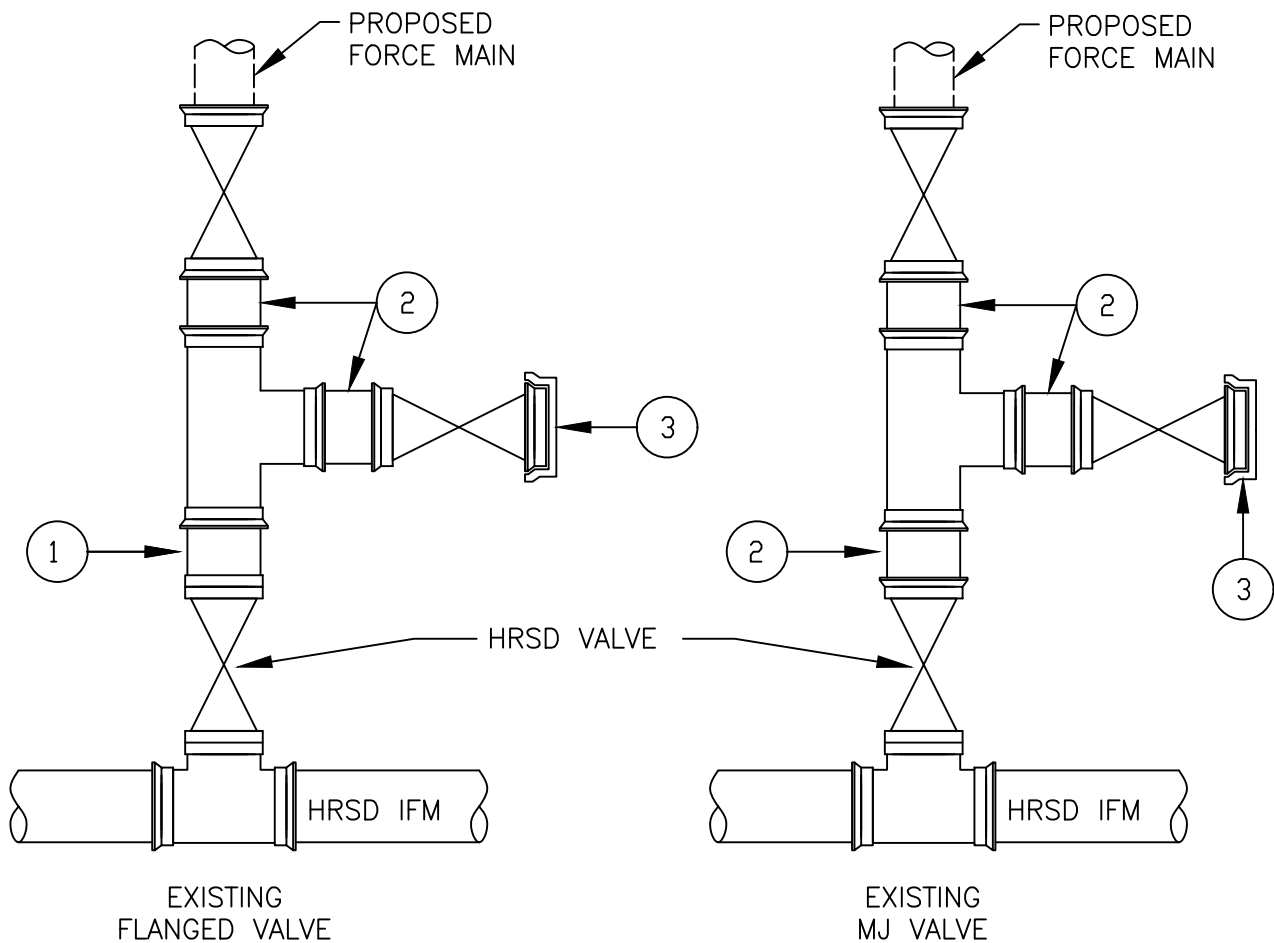

NOTES:

1. FL X PE NIPPLE WITH MEGA-LUG.
2. PE X PE NIPPLES WITH MEGA-LUGS. THE USE OF FOSTER ADAPTERS WILL BE CONSIDERED ON A CASE-BY-CASE BASIS BY HRSD.
3. MJ CAP/PLUG.
 - a. JURISDICTION TO OWN TEE AND VALVES UPSTREAM OF HRSD VALVE.
 - b. TEE AND JURISDICTION VALVES TO BE SAME SIZE AS EXISTING HRSD VALVE.
 - c. ECCENTRIC REDUCERS TO BE INSTALLED AS NEEDED AFTER JURISDICTION VALVE.
 - d. HRSD PIPELINES THAT HAVE CORROSION PROTECTION IN PLACE WILL REQUIRE AN ISOLATION COUPLING. CONTACT THE HRSD ENGINEER FOR DETAILS.

NOT TO SCALE



STANDARD DESIGN DETAIL

CONNECTION TO EXISTING HRSD VALVE WITH
IMMINENT DEVELOPMENT POTENTIAL

DRAWING NO.
302

SHEET
1 OF 1

DATE
2/2024

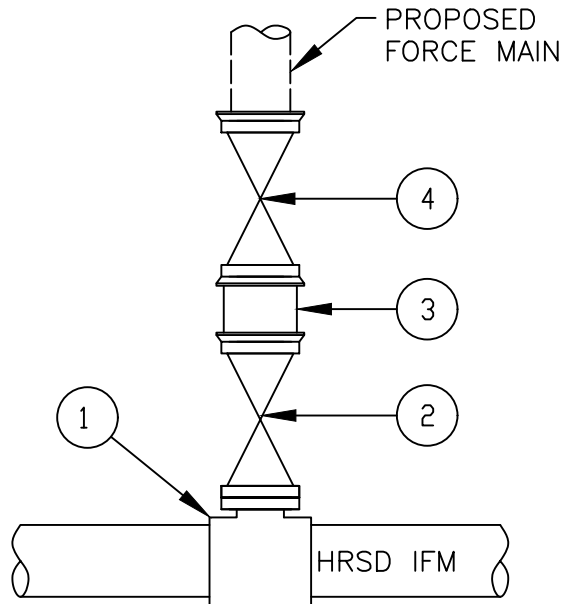

NOTES:

1. TAPPING SADDLE PER HRSD STANDARD DETAILS.
2. TAPPING VALVE (8"MIN.) (FL X MJ). TO BE OWNED BY HRSD.
3. FOSTER ADAPTER OR PE X PE NIPPLE WITH MEGA-LUGS USE OF FOSTER ADAPTORS SHALL BE APPROVED BY HRSD ON A CASE BY CASE BASIS.
4. JURISDICTION VALVE.
 - a. JURISDICTION VALVE TO BE SAME SIZE AS HRSD VALVE.
 - b. ECCENTRIC REDUCERS TO BE INSTALLED AS NEEDED AFTER JURISDICTION VALVE.
 - c. HRSD PIPELINES THAT HAVE CORROSION PROTECTION IN PLACE WILL REQUIRE AN ISOLATION COUPLING. CONTACT THE HRSD ENGINEER FOR DETAILS.

NOT TO SCALE

	STANDARD DESIGN DETAIL	DRAWING NO. 303
	NEW WET TAP WITH NO ADDITIONAL DEVELOPMENT POTENTIAL	SHEET 1 OF 1
		DATE 2/2024

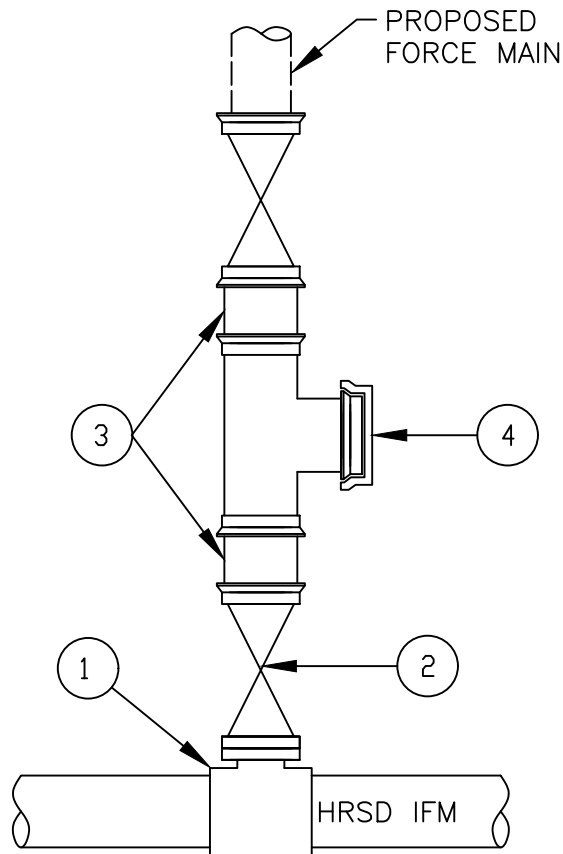

NOTES:

1. TAPPING SADDLE PER HRSD STANDARD DETAILS.
2. TAPPING VALVE (8"MIN.) (FL X MJ). TO BE OWNED BY HRSD.
3. FOSTER ADAPTORS OR PE X PE NIPPLES WITH MEGA-LUGS USE OF FOSTER ADAPTORS SHALL BE APPROVED BY HRSD ON A CASE BY CASE BASIS.
4. MJ CAP/PLUG.
 - a. JURISDICTION TO OWN TEE AND VALVE UPSTREAM OF HRSD VALVE.
 - b. TEE AND JURISDICTION VALVE TO BE SAME SIZE AS HRSD VALVE.
 - c. ECCENTRIC REDUCERS TO BE INSTALLED AS NEEDED AFTER JURISDICTION VALVE.
 - d. HRSD PIPELINES THAT HAVE CORROSION PROTECTION IN PLACE WILL REQUIRE AN ISOLATION COUPLING. CONTACT THE HRSD ENGINEER FOR DETAILS.

NOT TO SCALE

	STANDARD DESIGN DETAIL	DRAWING NO. 304
	NEW WET TAP WITH ADDITIONAL DEVELOPMENT POTENTIAL	SHEET 1 OF 1
		DATE 2/2024

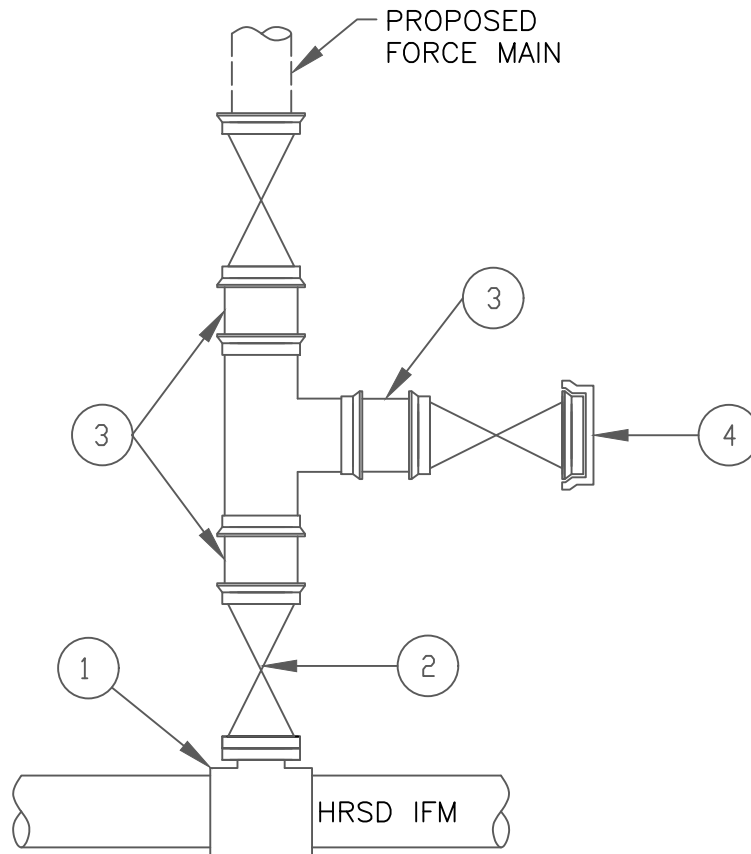

NOTES:

1. TAPPING SADDLE PER HRSD STANDARD DETAILS.
2. TAPPING VALVE (8"MIN.) (FL X MJ). TO BE OWNED BY HRSD.
3. FOSTER ADAPTORS OR PE X PE NIPPLES WITH MEGA-LUGS USE OF FOSTER ADAPTORS SHALL BE APPROVED BY HRSD ON A CASE BY CASE BASIS.
4. MJ CAP/PLUG.
 - a. JURISDICTION TO OWN TEE AND VALVES UPSTREAM OF HRSD VALVE.
 - b. TEE AND JURISDICTION VALVE TO BE SAME SIZE AS HRSD VALVE.
 - c. ECCENTRIC REDUCERS TO BE INSTALLED AS NEEDED AFTER JURISDICTION VALVE.
 - d. HRSD PIPELINES THAT HAVE CORROSION PROTECTION IN PLACE WILL REQUIRE AN ISOLATION COUPLING. CONTACT THE HRSD ENGINEER FOR DETAILS.

NOT TO SCALE



STANDARD DESIGN DETAIL

NEW WET TAP WITH
IMMINENT DEVELOPMENT POTENTIAL

DRAWING NO. 305
SHEET 1 OF 1
DATE 2/2024

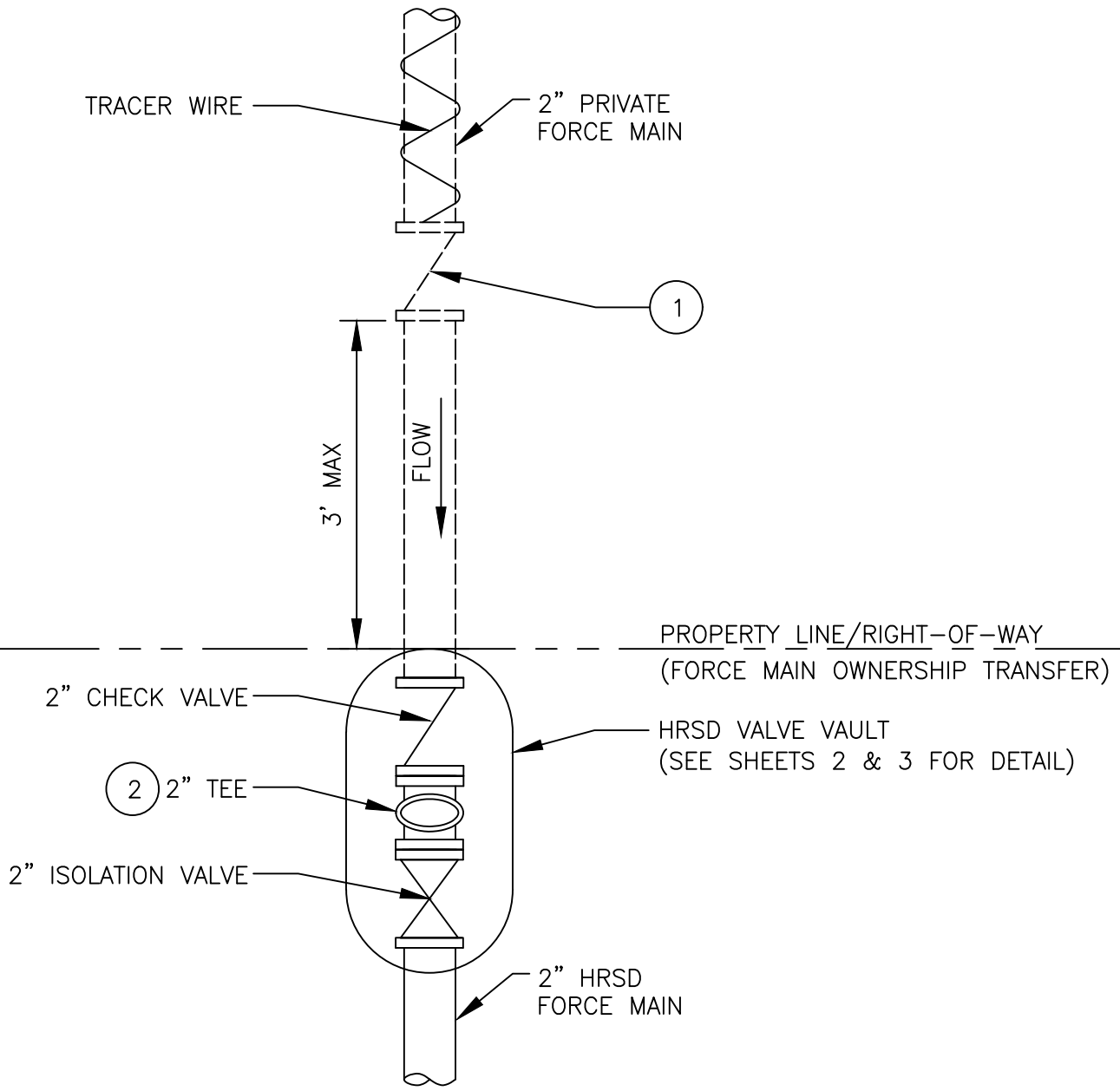

NOTES:

1. CHECK VALVE MUST BE INSTALLED ON PRIVATE DISCHARGE FORCE MAIN, INSIDE OF FRAME & COVER VB 7160 FROM CAPITAL FOUNDRY OF VIRGINIA.
2. ALL FITTINGS INSIDE OF HRSD VALVE VAULT SHALL BE 2" NPT.

NOT TO SCALE

	STANDARD DESIGN DETAIL	DRAWING NO. 306A
	2" PRIVATE FORCE MAIN CONNECTION TO EXISTING 2" HRSD FORCE MAIN STUB	SHEET 1 OF 3
		DATE 2/2024

2" VALVE VAULT

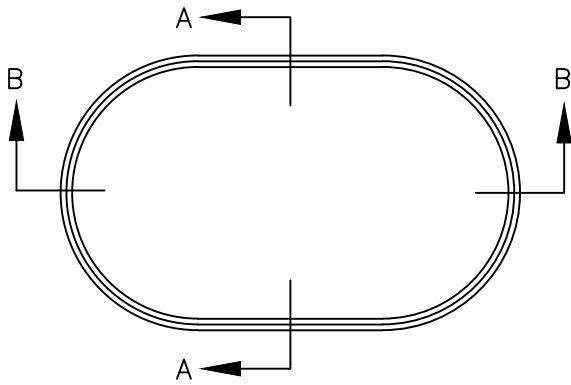

PLAN: VAULT

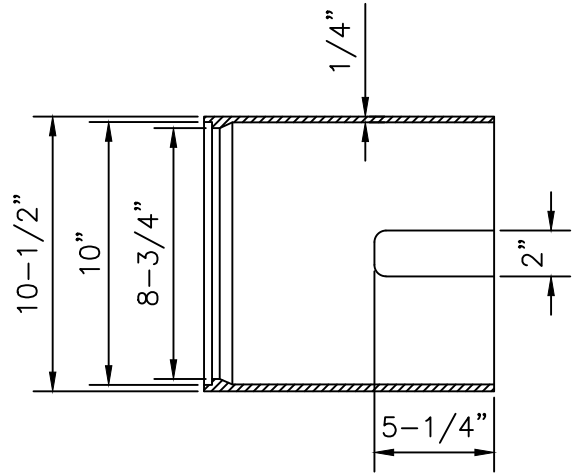

SECTION A-A

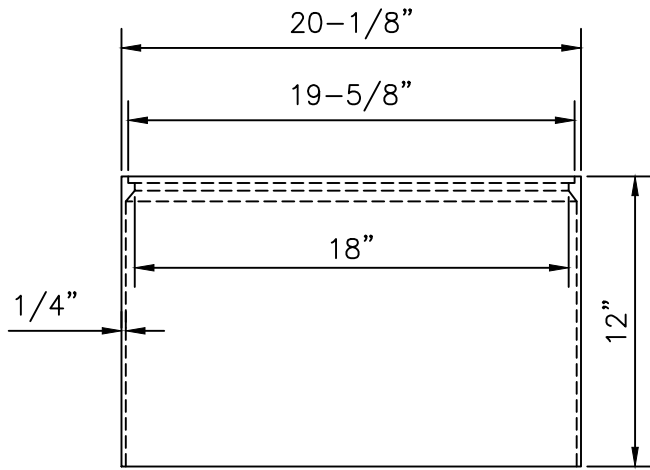

SECTION B-B

NOTES:

1. VALVE VAULT TO BE SUPPLIED BY CAPITAL FOUNDRY OF VIRGINIA, INC. (MODEL #MBX-1) OR APPROVED EQUAL.
2. ALL GRAY IRON CASTINGS SHALL CONFORM TO LATEST EDITION OF ASTM A-48, CLASS 30 AND SHALL BE OF UNIFORM QUALITY.
3. ALL CASTING DIMENSIONS SHALL HAVE A TOLERANCE OF 1/8"±.
4. ALL CASTINGS SHALL BE CLEANED BY SHOT BLASTING AND HAND CHIPPING UTILIZING STANDARD INDUSTRY PRACTICES PRIOR TO SHOP APPLICATION OF ASPHALTIC COATING, BY DIPPING.

NOT TO SCALE

	STANDARD DESIGN DETAIL	DRAWING NO. 306B
	2" PRIVATE FORCE MAIN CONNECTION TO EXISTING 2" HRSD FORCE MAIN STUB	SHEET 2 OF 3
		DATE 2/2024

2" VAULT LID

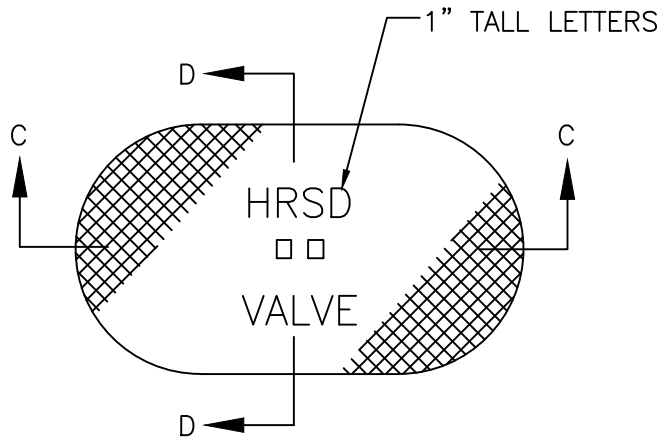

PLAN: LID

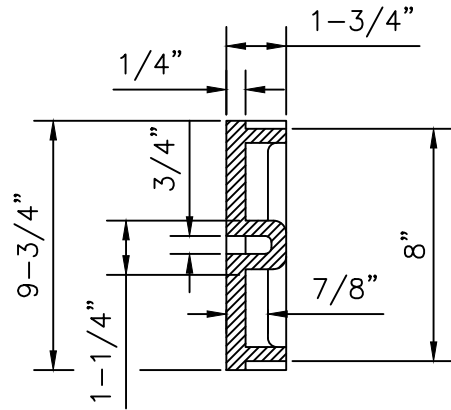

SECTION D-D

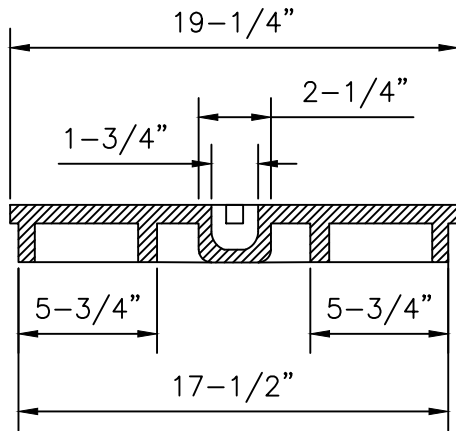

SECTION C-C

NOT TO SCALE



STANDARD DESIGN DETAIL

2" PRIVATE FORCE MAIN CONNECTION
TO EXISTING 2" HRSD FORCE MAIN STUB

DRAWING NO. 306C
SHEET 3 OF 3
DATE 2/2024

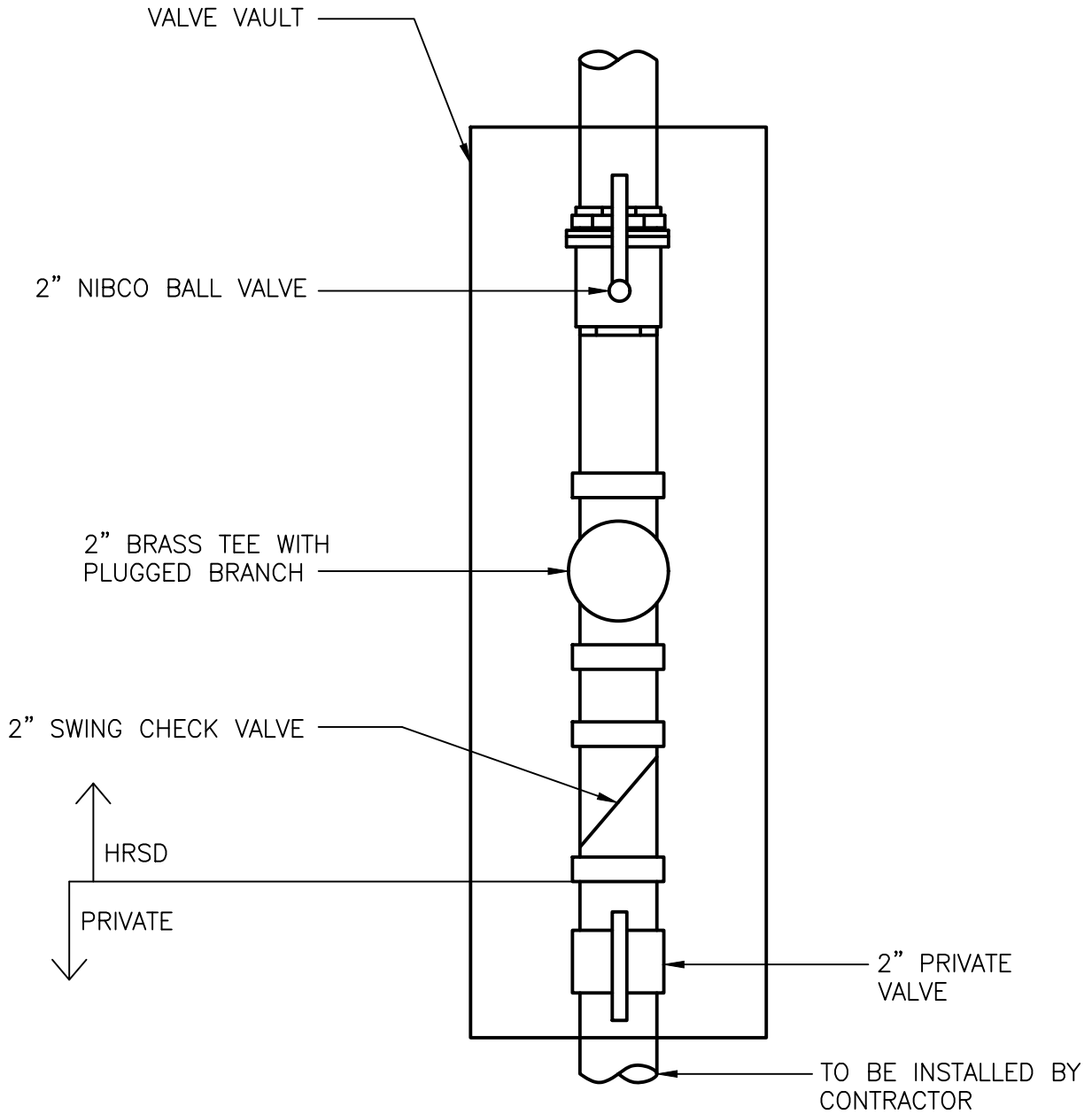

NOTES:

1. TRACER WIRE CAN BE TERMINATED INSIDE OF VALVE VAULT.
2. ALL FITTINGS AND PIPING TO BE BRASS WITH THREADED ENDS WITHIN THE VALVE VAULT.
3. OPERATION OF HRSD VALVES SHALL BE DONE BY HRSD PERSONNEL ONLY.
4. DEVIATION FROM THIS DETAIL WILL REQUIRE APPROVAL FROM HRSD.

NOT TO SCALE

	STANDARD DESIGN DETAIL	DRAWING NO. 307
	LAWNES POINT PRIVATE CONNECTION DETAIL	SHEET 1 OF 1
		DATE 2/2024

PRIVATELY OWNED GRINDER PIT (MUST HAVE CHECK VALVE FOLLOWED BY ISOLATION VALVE ON DISCHARGE PIPING)

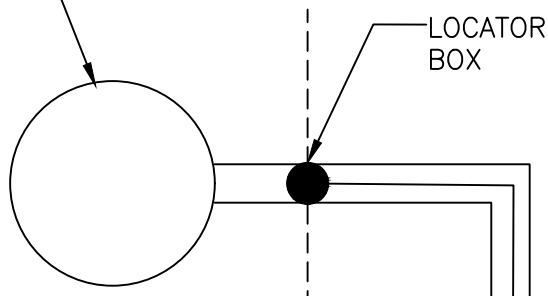

PRIVATE PROPERTY LINE/ ROW

ALL BURIED PIPING SHALL BE HDPE DR-26, IF FUSION IS REQUIRED IT SHALL BE BUTT FUSION WELDED

TRACER WIRE AWG-10 SOLID COPPER WIRE W/POLYETHYLENE INSULATION. SHALL BE TAPED AT A MAXIMUM INTERVAL OF 4'.

HRSD MANHOLE

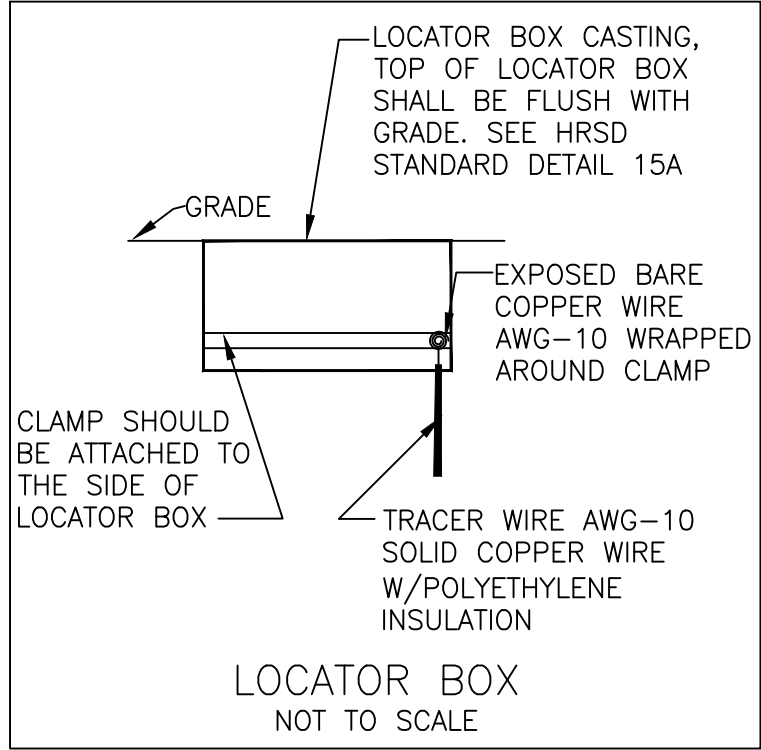

LOCATOR BOX NOT TO SCALE

PIPE DIAMETER SHALL BE MAX 4"

SEE FORCE MAIN DETAIL FOR EITHER EXTERNAL/INTERNAL DROP

NOT TO SCALE



STANDARD DESIGN DETAIL

PRIVATE FORCE MAIN CONNECTION TO HRSD MANHOLE

DRAWING NO.	308
SHEET	1 OF 1
DATE	2/2024

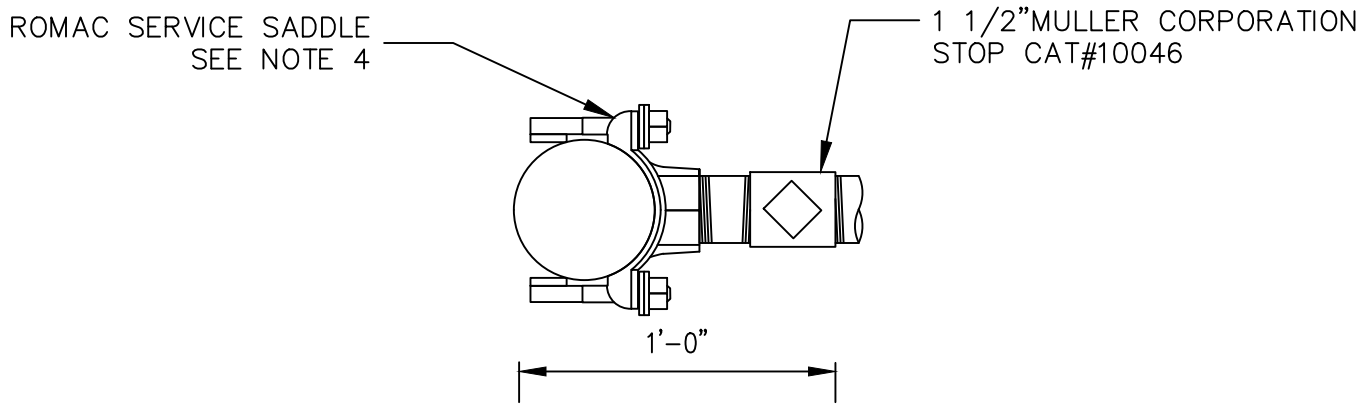
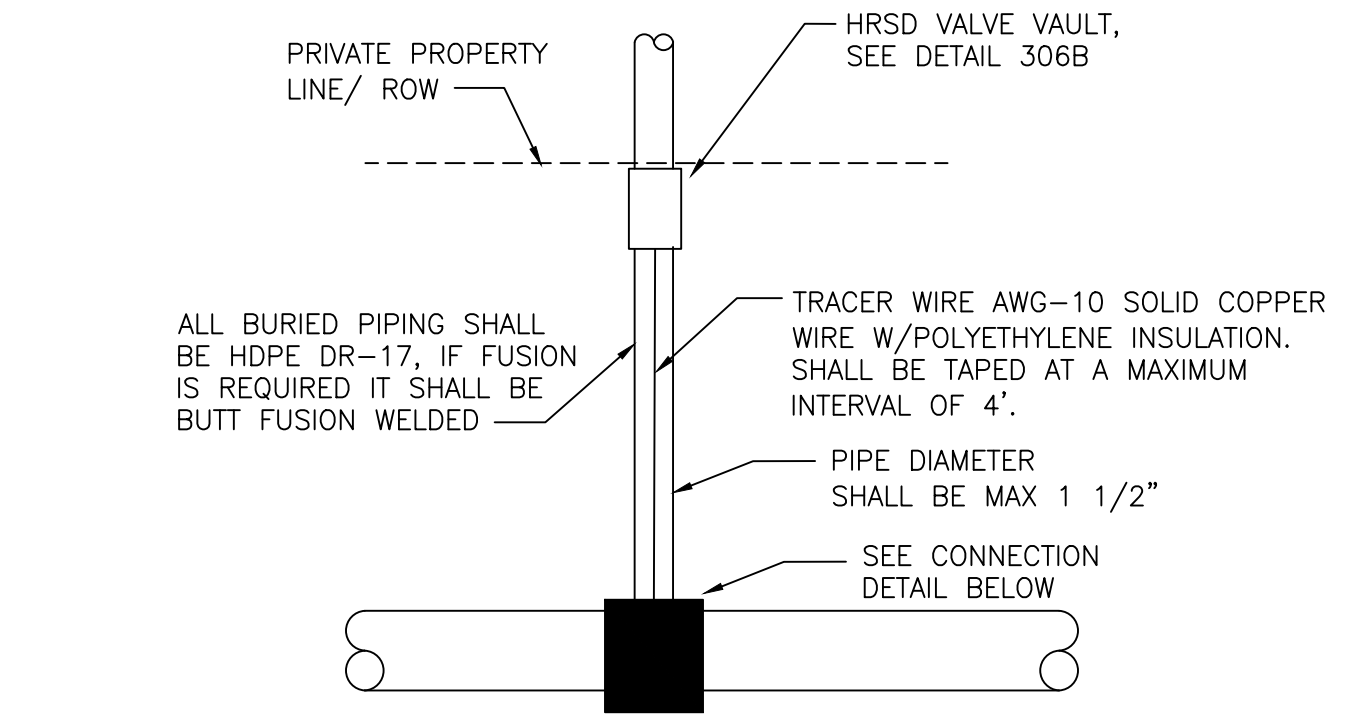

CONNECTION DETAIL

NOTE:

1. TAP WILL BE COMPLETED BY HRSD APPROVED CONTRACTOR. CONTRACTOR IS RESPONSIBLE FOR CONFIRMING PIPE MATERIAL AND SIZE, PROCURING CORRECT MATERIAL, EXCAVATION AND TRENCH SHORING, BACKFILLING AND INSTALLING HRSD VALVE AND ALL ASSOCIATED FITTINGS AND PIPE INSTALLATION.
2. TYPE IV BEDDING IS REQUIRED FOR THIS CONNECTION. SEE HRPDC DETAIL EW_01
3. REFER TO STANDARD DETAIL 306B FOR VAULT DETAIL
4. SERVICE CONNECTION SHALL BE ROMAC SERVICE SADDLE 202

NOT TO SCALE

	STANDARD DESIGN DETAIL	DRAWING NO. 309
	PRIVATE FORCE MAIN SERVICE CONNECTION SADDLE TO EXISTING HRSD FORCE MAIN	SHEET 1 OF 1
		DATE 2/2024

EXISTING GRADE OR PAVEMENT

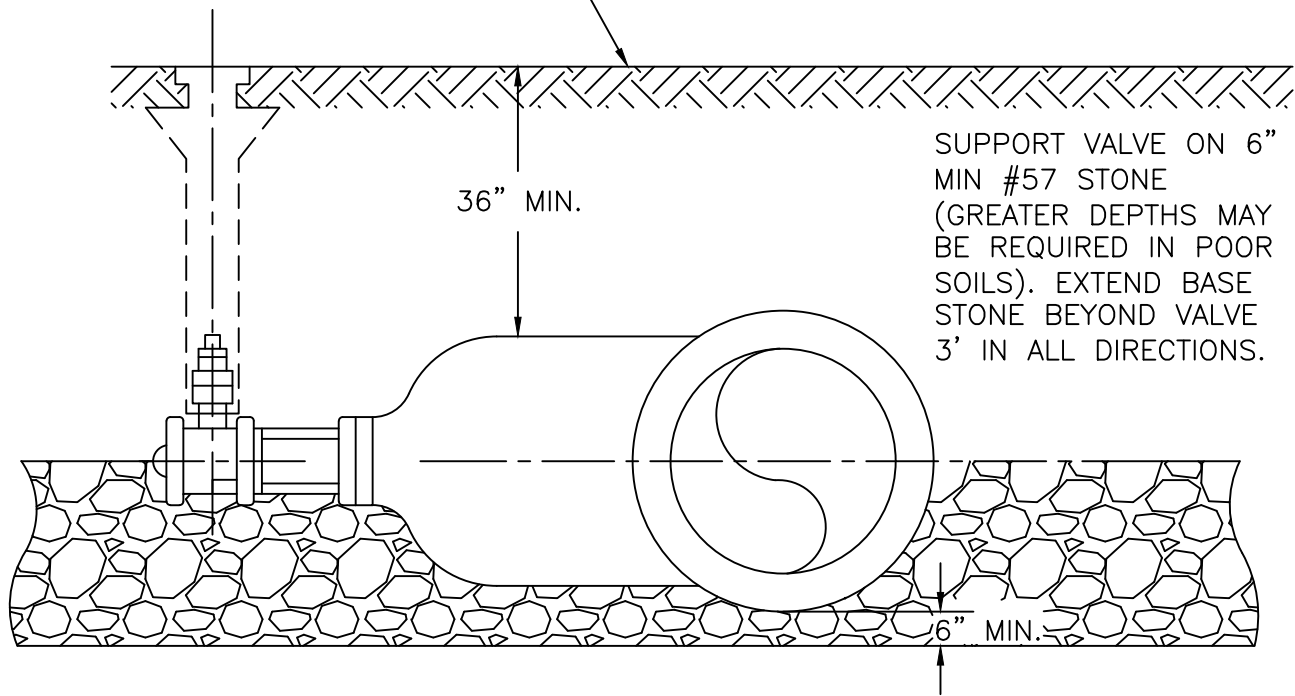

SUPPORT VALVE ON 6"
MIN #57 STONE
(GREATER DEPTHS MAY
BE REQUIRED IN POOR
SOILS). EXTEND BASE
STONE BEYOND VALVE
3' IN ALL DIRECTIONS.

36" MIN.

6" MIN.

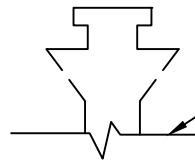

VALVE BOX & RISER
SEE HRSD STANDARD
DETAIL #11

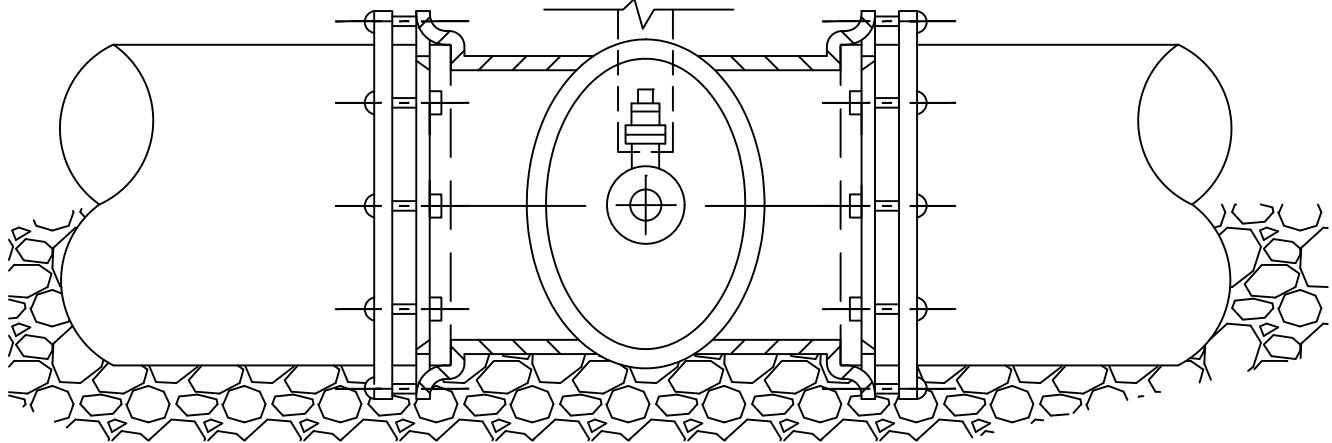

NOTE:

1. SEE SPECIFICATIONS FOR HORIZONTAL OR VERTICAL POSITION AND BY-PASS REQUIREMENT.
2. EXTENSION STEMS ARE NOT ACCEPTABLE.
3. INSTALL CRIBBING AS NECESSARY.

NOT TO SCALE



STANDARD DESIGN DETAIL

HORIZONTAL GATE VALVE

DRAWING NO.

326

SHEET

1 OF 1

DATE

2/2024

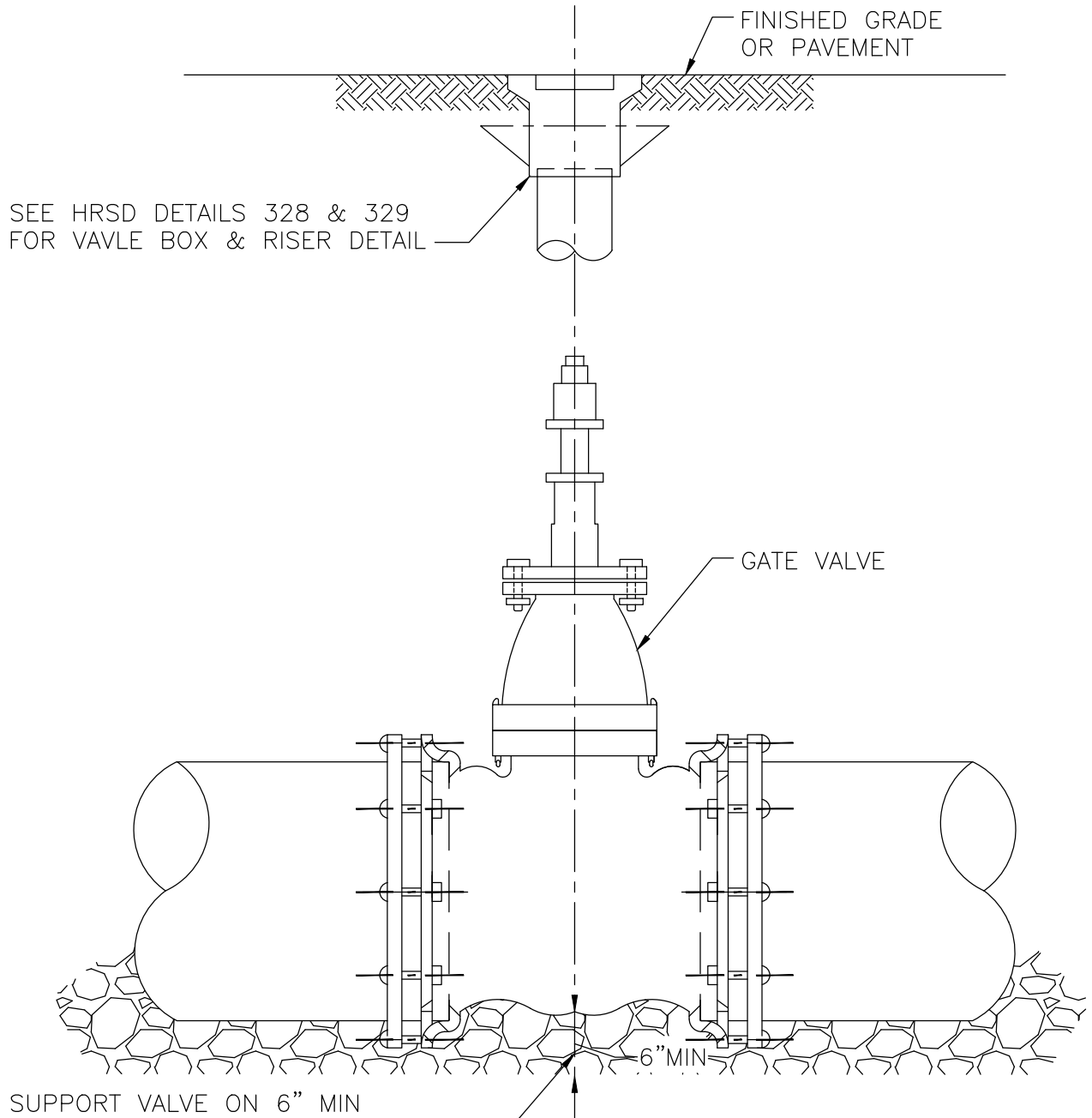

SEE HRSD DETAILS 328 & 329
FOR VAVLE BOX & RISER DETAIL

GATE VALVE

6" MIN

SUPPORT VALVE ON 6" MIN
#57 STONE (GREATER DEPTHS
MAY BE REQUIRED IN POOR
SOILS). EXTEND BASE BEYOND
VALVE 3' IN ALL DIRECTIONS.

NOTE:

1. SEE SPECIFICATIONS FOR HORIZONTAL OR VERTICAL POSITION AND BYPASS REQUIREMENT.
2. EXTENSION SYSTEMS ARE NOT ACCEPTABLE.
3. INSTALL CRIBBING AS NECESSARY.
4. THIS DETAIL ONLY APPLICABLE FOR VALVES 14" AND SMALLER.
5. MINIMUM VALVE SIZE SHALL BE 8".

NOT TO SCALE

	STANDARD DESIGN DETAIL	DRAWING NO. 327
	VERTICAL GATE VALVE	SHEET 1 OF 1
		DATE 2/2024

MINIMUM WEIGHTS:
 COVER - 22 LBS.
 FRAME - 110 LBS.

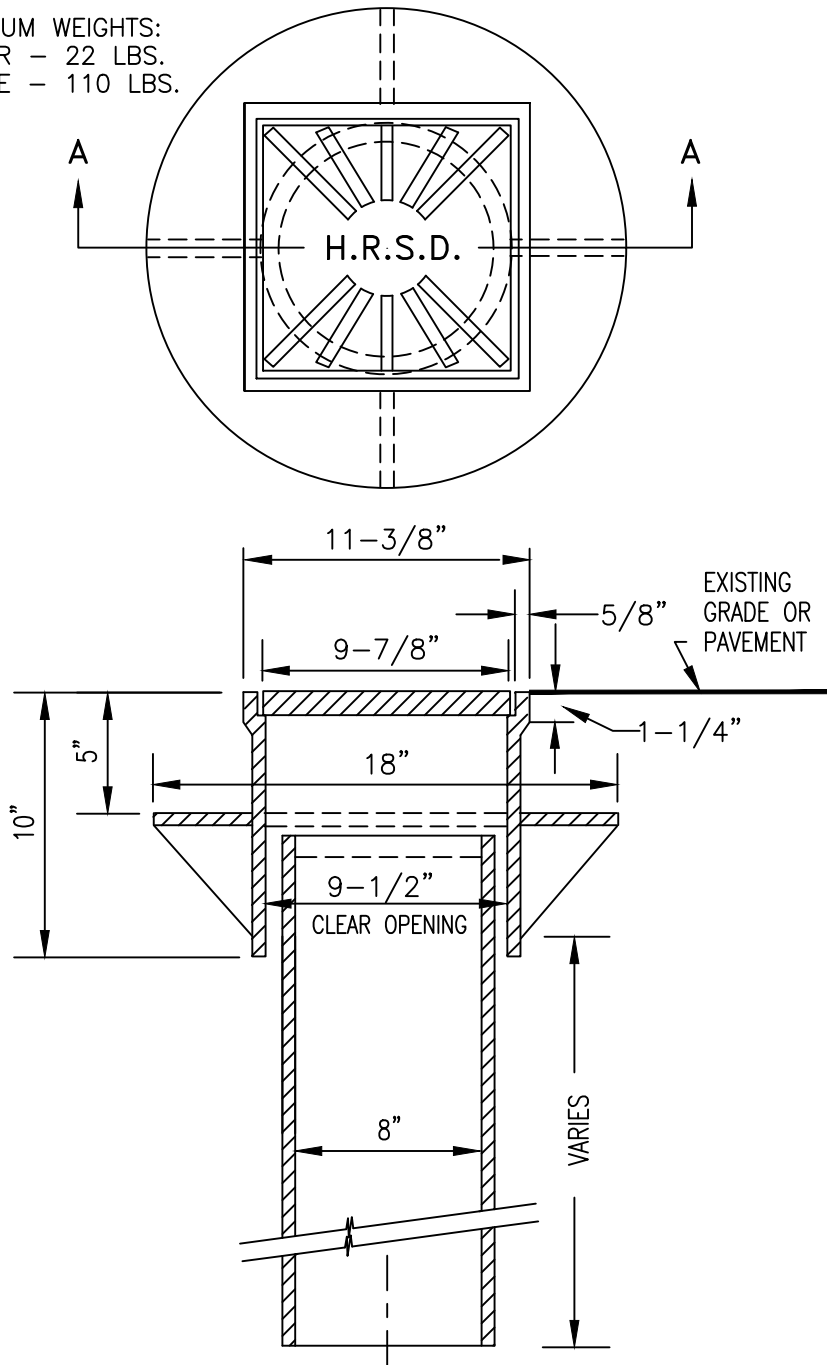

SECTION A-A

NOTES:

1. RISER TO BE 8" C900 PVC OR 8" SCH. 80 PVC. (ONE PIECE).
 BELL END PIECE SHALL NOT BE ALLOWED.
2. TOLERANCE TO BE +/- .125" FOR ALL DIMENSIONS.
3. CASTING TO BE SHOT BLASTED.
4. CASTING TO BE ASTM A-48 CLASS 30.
5. JACK UP RINGS NOT ACCEPTABLE.
6. TOP OF RISER PIPE SHALL BE 5" BELOW THE LIP FOR THE CASTING LID.
7. RISER SHALL BE CENTERED ON THE FORCE MAIN AND SHALL BE PLUMB AND STRAIGHT.
8. SEE MASTER SPEC SECTION 0134 FOR AMERICAN IRON AND STEEL REQUIREMENT.

NOT TO SCALE



STANDARD DESIGN DETAIL

VALVE BOX & RISER FOR MAINLINE VALVE

DRAWING NO.

328

SHEET

1 OF 1

DATE

2/2024

MINIMUM WEIGHTS:
 COVER - 25 LBS.
 FRAME - 75 LBS.

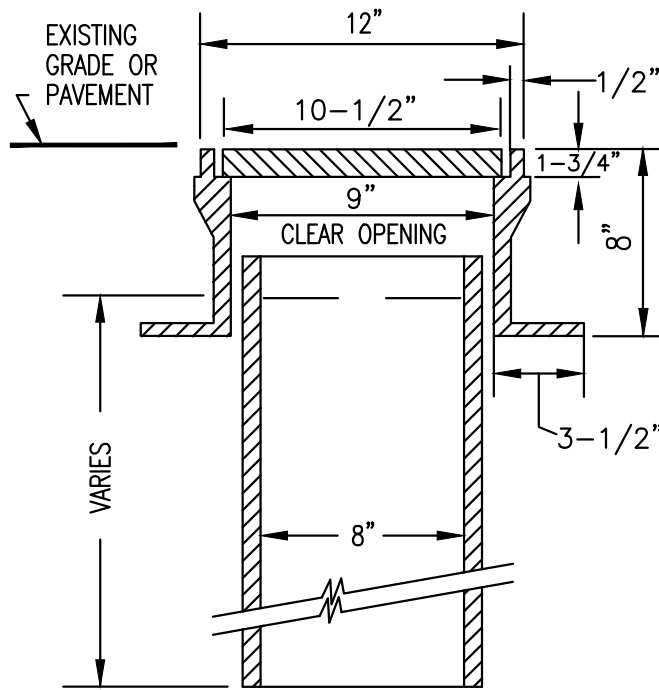
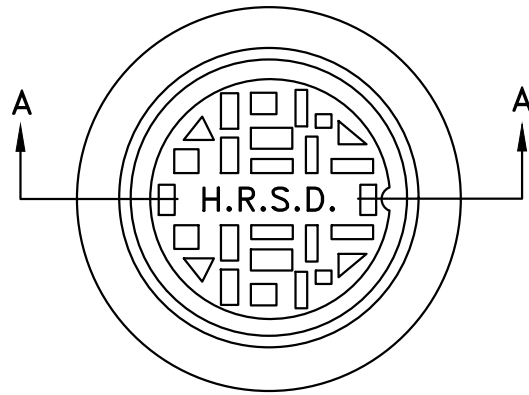

SECTION A-A

NOTES:

1. RISER TO BE 8" C900 PVC OR 8" SCH. 80 PVC. (ONE PIECE).
BELL END PIECE SHALL NOT BE ALLOWED.
2. TOLERANCE TO BE $\pm .125$ " FOR ALL DIMENSIONS.
3. CASTING TO BE SHOT BLASTED.
4. CASTING TO BE ASTM A-48 CLASS 30.
5. JACK UP RINGS NOT ACCEPTABLE.
6. TOP OF RISER PIPE SHALL BE 5" BELOW THE LIP FOR THE CASTING LID.
7. RISER SHALL BE CENTERED ON THE NUT AND SHALL BE PLUMB AND STRAIGHT.
8. SEE MASTER SPEC SECTION 01340 FOR AMERICAN IRON AND STEEL REQUIREMENT.

NOT TO SCALE



STANDARD DESIGN DETAIL

VALVE BOX & RISER FOR BYPASS VALVES

DRAWING NO.

329

SHEET

1 OF 1

DATE

2/2024

MINIMUM WEIGHTS:
 COVER — 22 LBS.
 FRAME — 110 LBS.

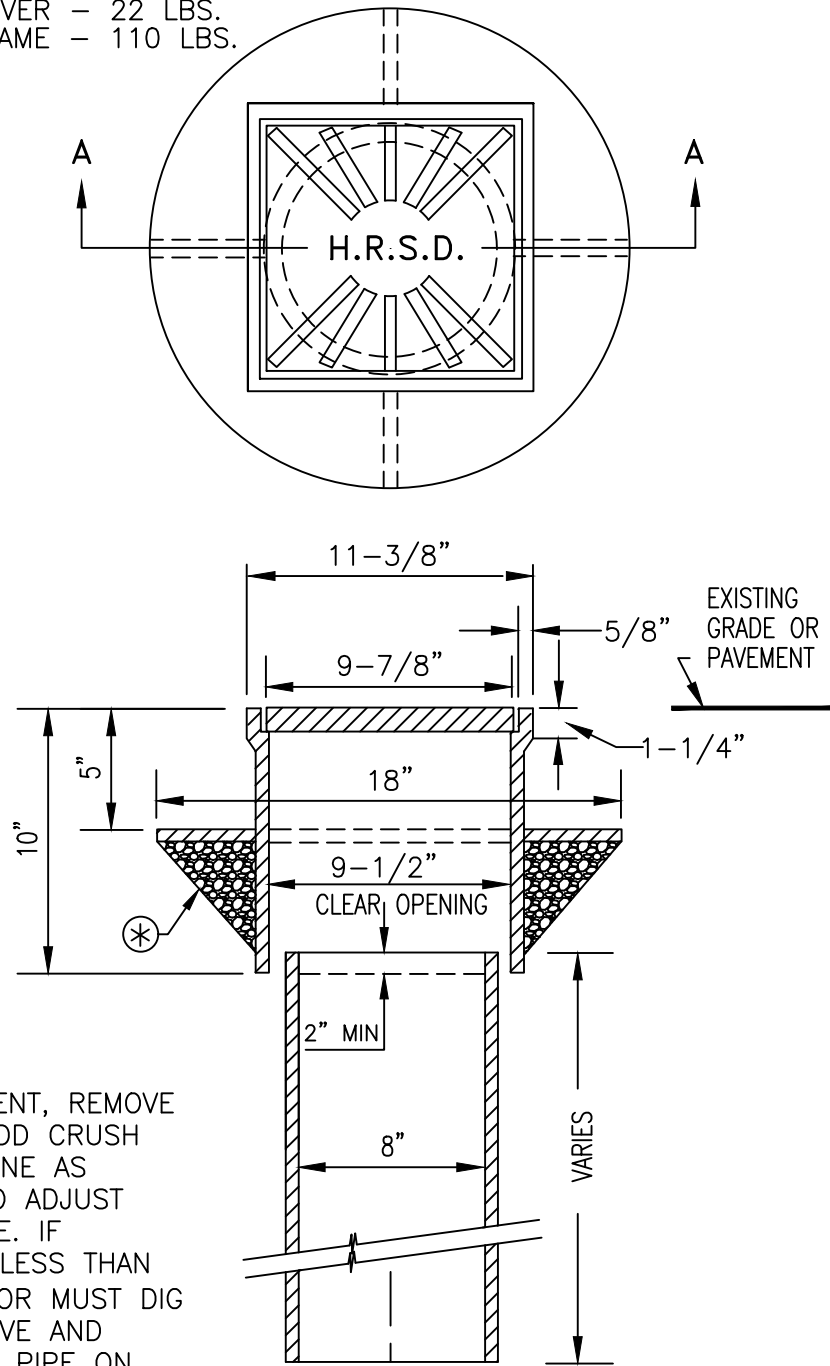

⊛ FOR ADJUSTMENT, REMOVE FRAME AND ADD CRUSH AND RUN STONE AS NECESSARY TO ADJUST TOP TO GRADE. IF INSERTION IS LESS THAN 2", CONTRACTOR MUST DIG DOWN ON VALVE AND ADJUST RISER PIPE ON VALVE BY ADDING STONE OR NEW 8" PIPE OF APPROPRIATE LENGTH.

SECTION A-A

FOR USE ON MAINLINE
 OR CONNECTION VALVES

NOTES:

1. SEE MASTER SPEC SECTION 01340 FOR AMERICAN IRON AND STEEL REQUIREMENT.

NOT TO SCALE



STANDARD DESIGN DETAIL

VALVE RISER ADJUSTMENT

DRAWING NO.

330

SHEET

1 OF 1

DATE

2/2024

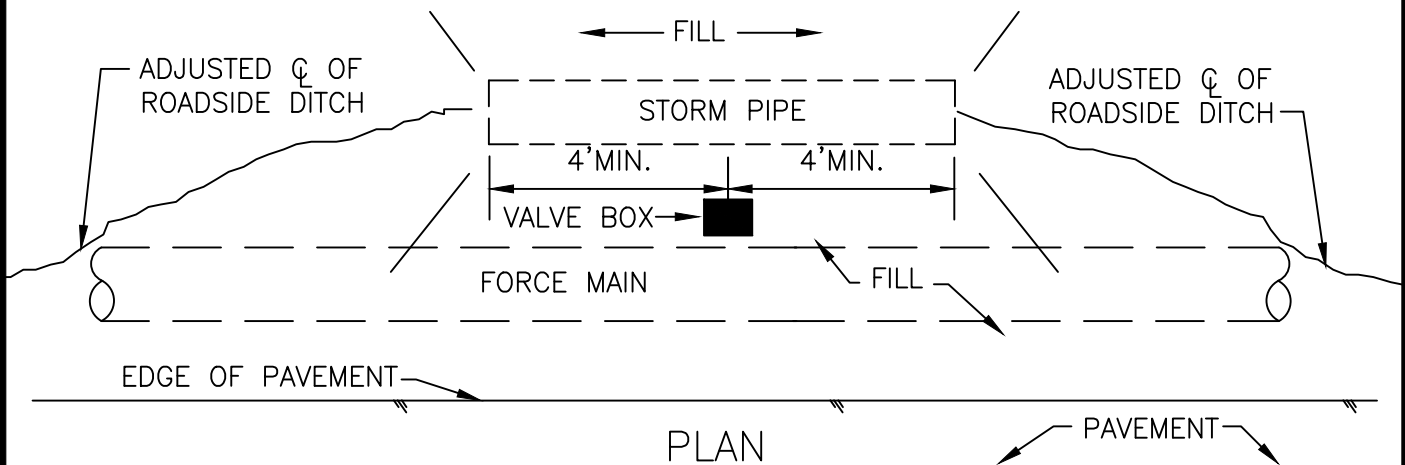
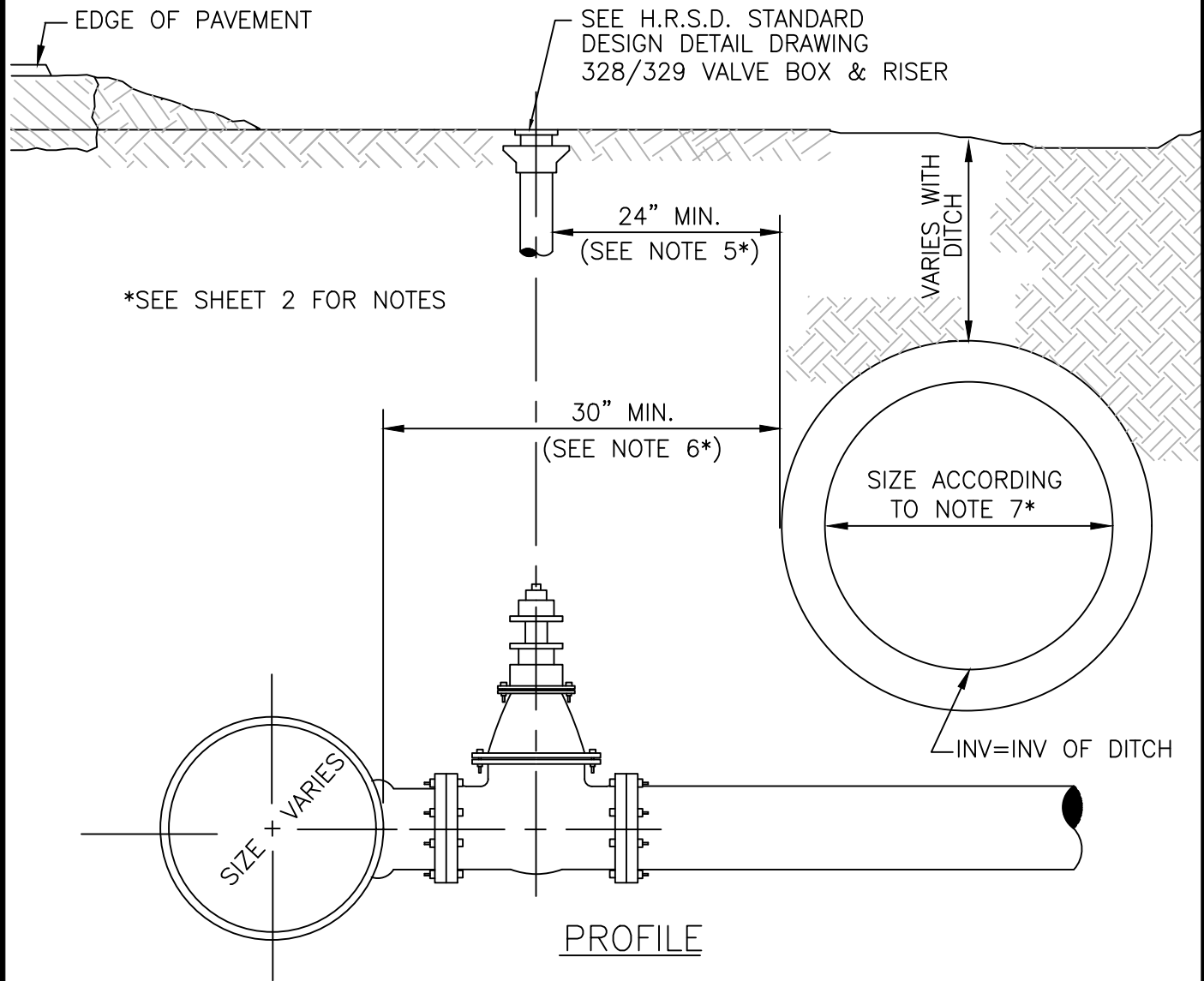

NOT TO SCALE

	STANDARD DESIGN DETAIL	DRAWING NO. 331A
	ROADSIDE DITCH VALVE BOX	SHEET 1 OF 2
		DATE 2/2024

NOTES:

1. VALVE BOXES ARE TO BE ALIGNED TRUE AND SQUARE WITH EDGE OF PAVEMENT.
2. STORM PIPE SHALL EXTEND A MINIMUM OF FOUR (4) FEET TO EITHER SIDE OF VALVE BOX.
3. FILL MATERIAL SHALL CONFORM TO RIGHT OF WAY PERMIT REQUIREMENTS.
4. SLOPE FILL MATERIAL TO DRAIN AWAY FROM VALVE BOX TOWARDS DITCH.
5. MAINTAIN 24 INCH MINIMUM HORIZONTAL DISTANCE BETWEEN STORM PIPE AND VALVE RISER PIPE.
6. WHEN VALVE FACES AWAY FROM DITCH, MAINTAIN 30 INCH MINIMUM HORIZONTAL DISTANCE BETWEEN STORM PIPE AND FORCE MAIN.
7. STORM PIPE SHALL BE SIZED IN ACCORDANCE WITH RIGHT OF WAY PERMIT.
8. UPON COMPLETION OF VALVE BOX AND STORM PIPE INSTALLATION, CONTACT HRSD INSPECTOR FOR FINAL INSPECTION.

	STANDARD DESIGN DETAIL	DRAWING NO. 331B
	ROADSIDE DITCH VALVE BOX	SHEET 2 OF 2
		DATE 2/2024

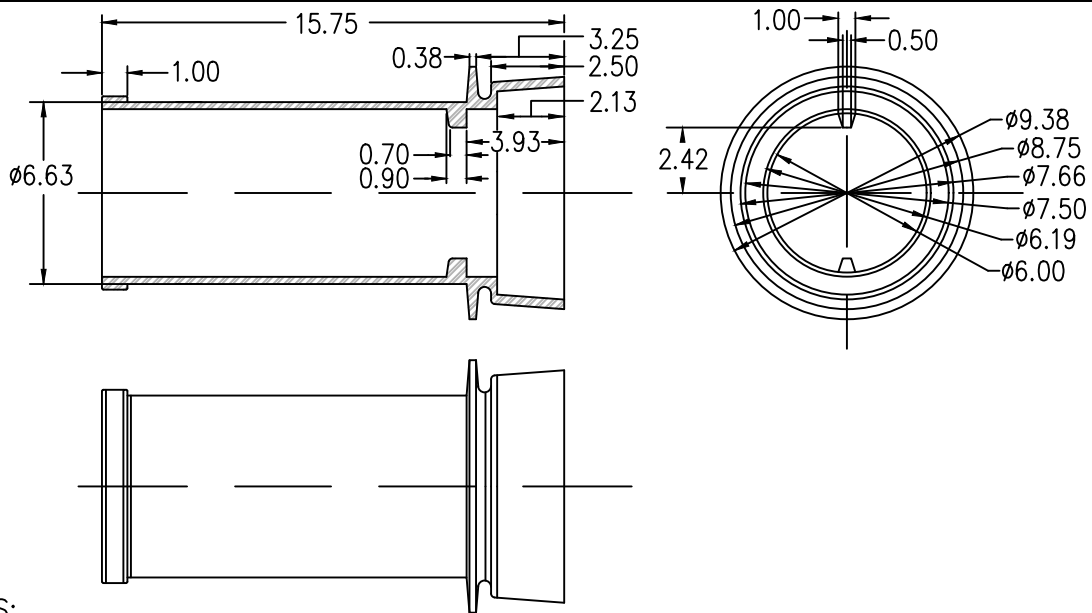

NOTES:

1. MATERIAL, CAST IRON, GRADE TO BE SPECIFIED ON PURCHASE ORDER.
2. ALL RADII SHALL BE 1/16" MINIMUM.
3. ESTIMATED WEIGHT 37#.

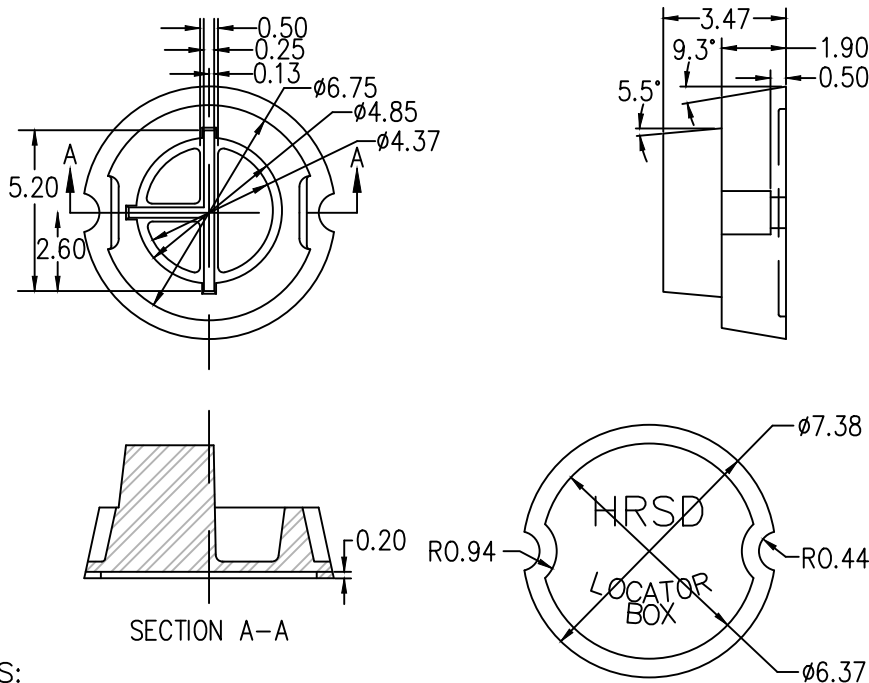

NOTES:

1. ALL INTERNAL EDGES SHALL HAVE A 1/16" RADIUS.
2. ALL EXTERNAL RADII 1/16" TO 1/8" AS NEEDED FOR CASTING RELIEF.
3. MATERIAL, CAST IRON, GRADE TO BE SPECIFIED ON PURCHASE ORDER.
4. ESTIMATED WEIGHT 12#.
5. RISER TO BE FILLED WITH PEA GRAVEL.

NOT TO SCALE

	STANDARD DESIGN DETAIL	DRAWING NO. 332
	TRACER WIRE LOCATOR BOX	SHEET 1 OF 1
		DATE 2/2024

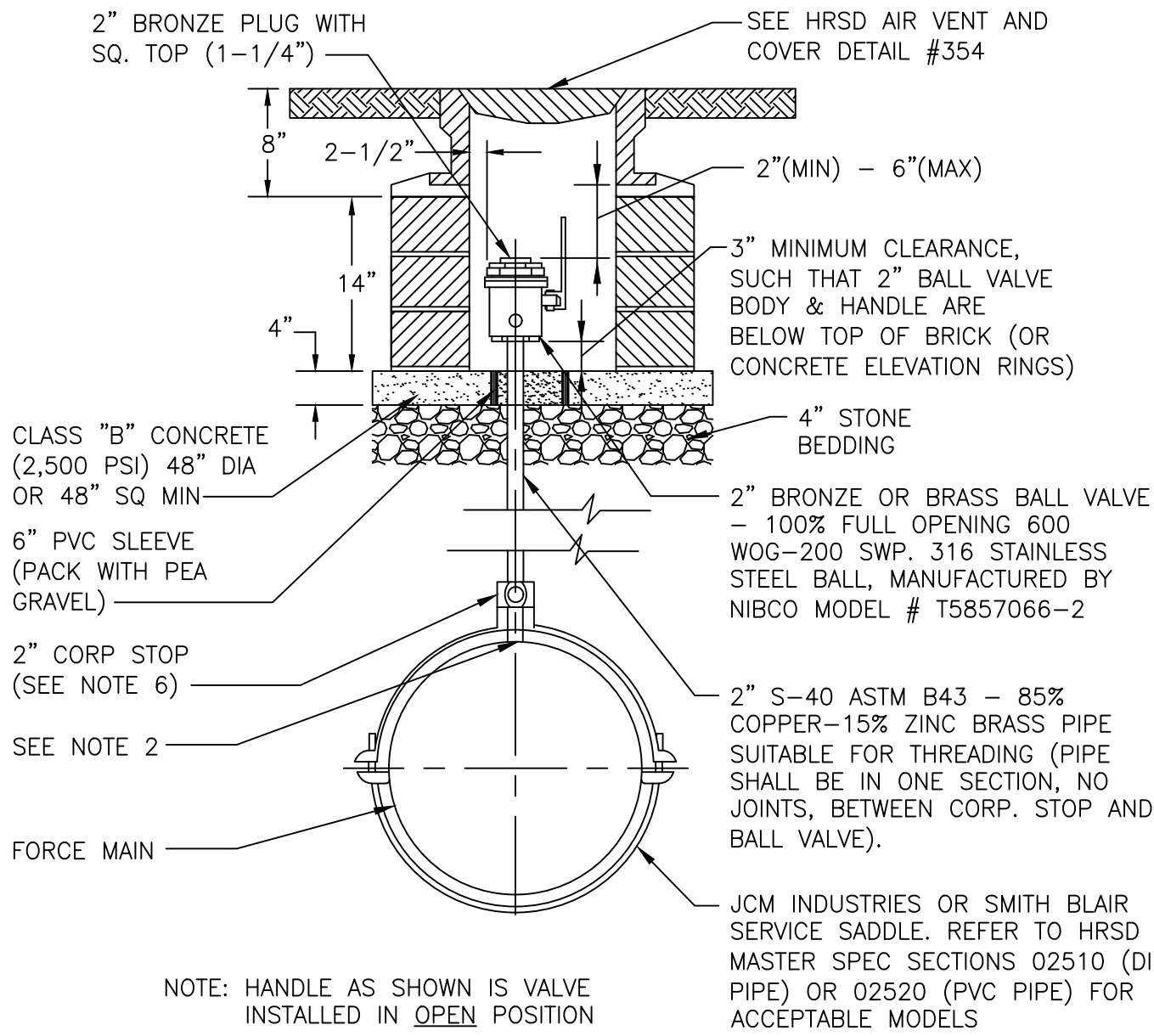

NOTES:

1. CONSTRUCT AIR VENT USING REQUIRED NUMBER OF COURSES OF HARD SOUND COMMON BRICK LAID ON EDGE OR CONCRETE ELEVATION RINGS AS MANUFACTURED BY NANSEMOND PRE-CAST CONCRETE CO, INC. MODEL AV-ER-CH AND AV-BS.
2. 2" TAP FOR AIR VENT SHALL BE STANDARD SADDLE TAP.
3. SERVICE SADDLE COATING SHALL BE FUSION BONDED EPOXY. SADDLE STRAPS AND HARDWARE SHALL BE STAINLESS STEEL. STAINLESS STEEL SHALL BE MINIMUM 304.
4. JACK UP RINGS BETWEEN THE FRAME AND COVER NOT ACCEPTABLE.
5. PARGE BRICK WORK OR CONCRETE ELEVATION RINGS WITH GROUT INSIDE AND OUT, CONTINUE ONTO CASTING.
6. MUELLER CATALOG NUMBER H10045N IS PREFERRED. REFER TO SPECIFICATION SECTION 02610 FOR ALLOWABLE ALTERNATIVES IF THE CONTRACTOR HAS DEMONSTRATED THE PREFERRED MODEL IS NOT AVAILABLE.

NOT TO SCALE

	STANDARD DESIGN DETAIL	DRAWING NO. 351
	MANUAL AIR VENT	SHEET 1 OF 1
		DATE 2/2024

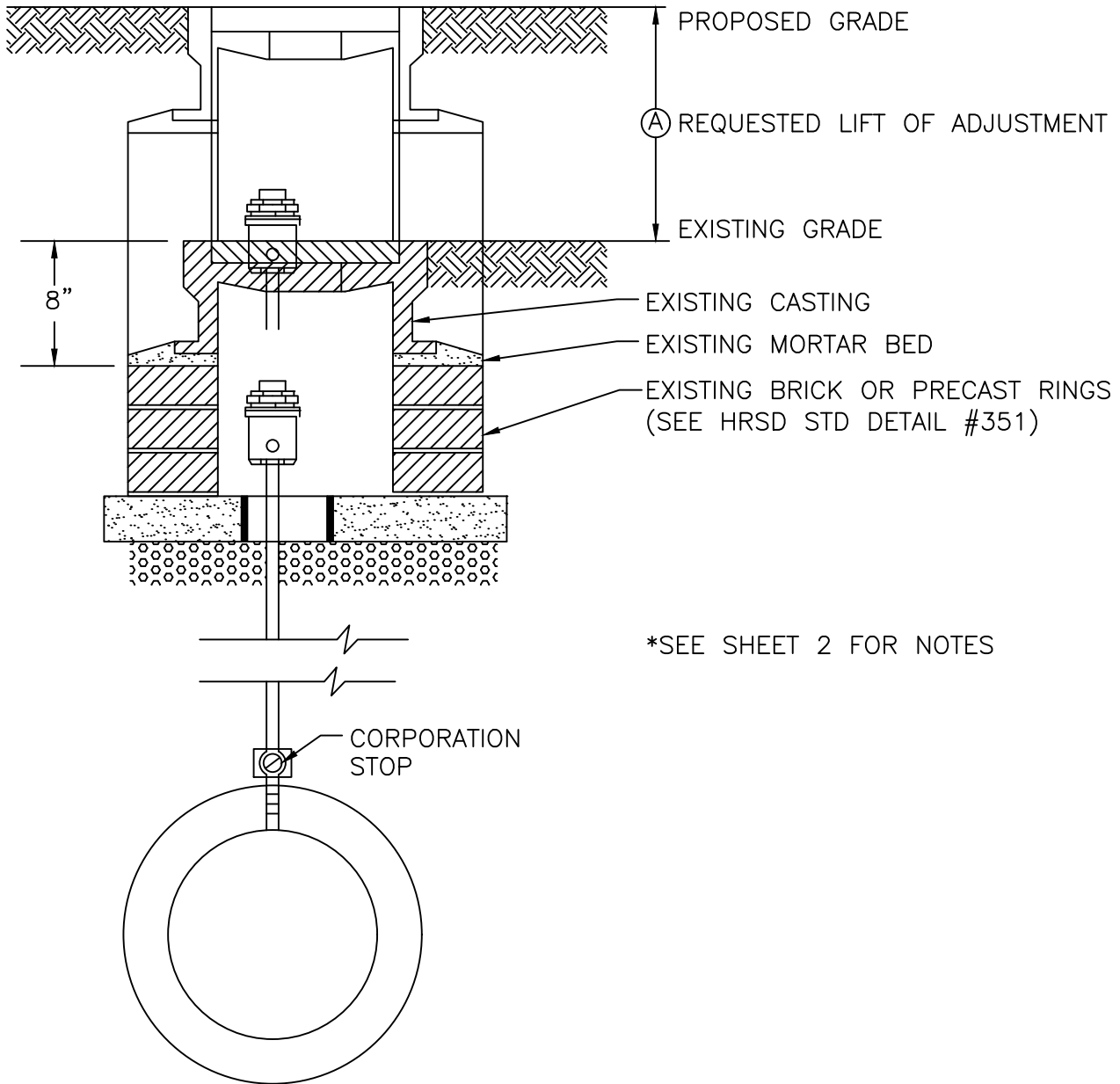

NOT TO SCALE



STANDARD DESIGN DETAIL

AIR RELEASE VALVE BOX ADJUSTMENT

DRAWING NO.
352A

SHEET
1 OF 2

DATE
2/2024

GENERAL ADJUSTMENT NOTES:

1. REFER TO HRSD STD. DETAIL #351 FOR TYPICAL AIR VENT VALVE BOX CONSTRUCTION.
2. REFER TO HRSD STD. DETAIL #354 FOR AIR VENT VALVE BOX CASTING LID AND FRAME (IF CASTING ON SITE IS NOT AS SHOWN IN DETAIL #354, NOTIFY HRSD ENGINEER).
3. TOP OF VALVE'S BRONZE PLUG SHALL BE NO CLOSER TO BOTTOM OF FRAME THAN TWO (2") INCHES NOR FARTHER THAN SIX (6") INCHES.
4. BED CAST IRON FRAME SOUNDLY IN MORTAR GROUT.
5. PARGE ENTIRE VALVE BOX (INSIDE & OUT) WITH GROUT.

LOWERING TO GRADE:

6. EXCAVATE TO CORPORATION STOP AND CLOSE IT.
7. REMOVE AND REPLACE BALL VALVE AND RISER PIPE.
8. OPEN CORPORATION STOP 100%. MODIFY/RECONSTRUCT BOX AS REQUIRED.

RAISING OF GRADE:

9. WHEN ADJUSTMENT "A" DOES NOT VIOLATE NOTE #3, ABOVE, CASTING MAY BE LIFTED BY REMOVING EXISTING MORTAR BED AND ADDING COURSES OF HARD, SOUND, COMMON BRICK OR CONCRETE ELEVATION RINGS.
10. WHEN ADJUSTMENT "A" VIOLATES NOTE #3, FOLLOW STEPS 6-8 ABOVE.

	STANDARD DESIGN DETAIL	DRAWING NO. 352B
		SHEET 2 OF 2
	AIR RELEASE VALVE BOX ADJUSTMENT	DATE 2/2024

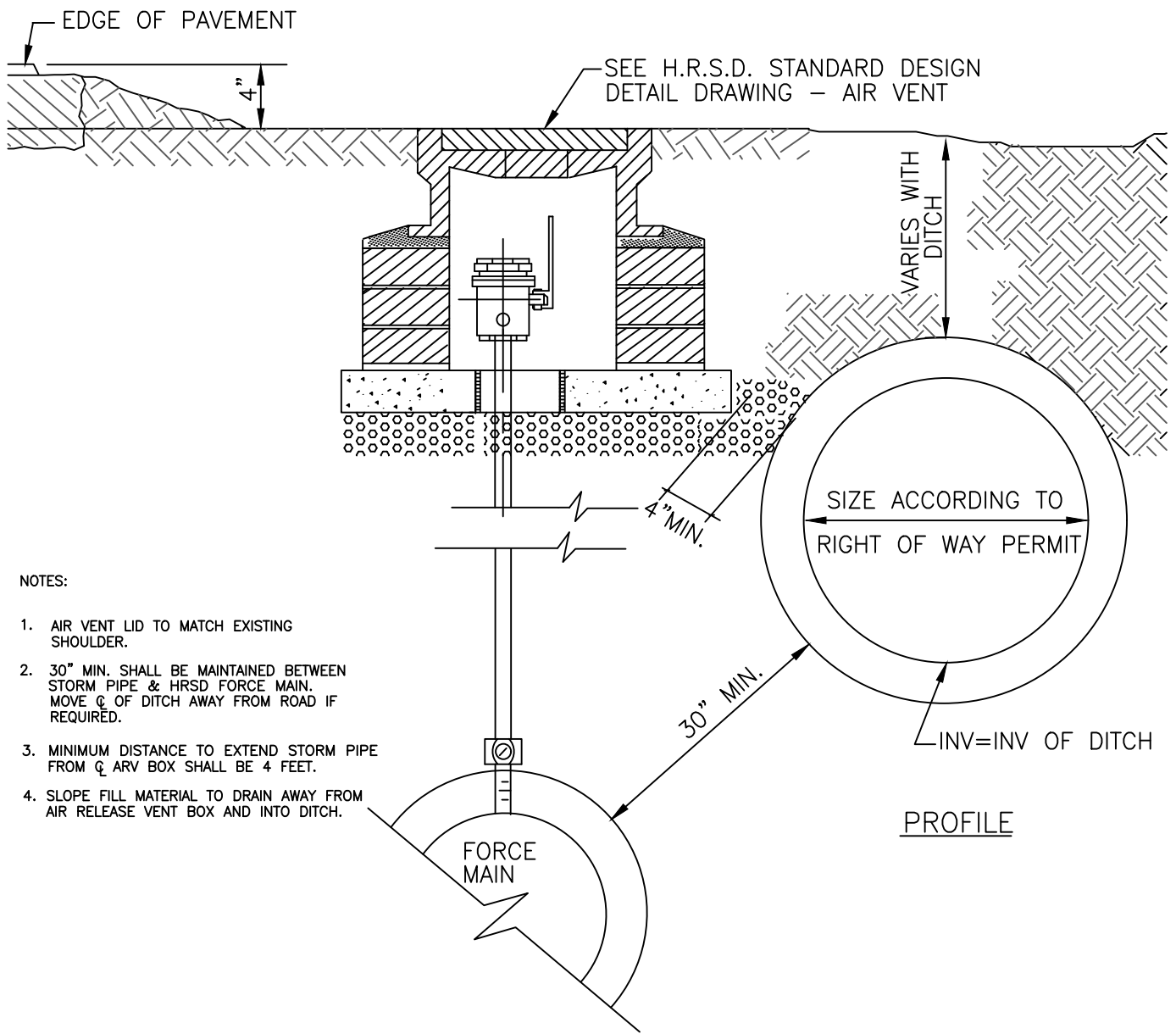

NOTES:

1. AIR VENT LID TO MATCH EXISTING SHOULDER.
2. 30" MIN. SHALL BE MAINTAINED BETWEEN STORM PIPE & HRSD FORCE MAIN. MOVE ϕ OF DITCH AWAY FROM ROAD IF REQUIRED.
3. MINIMUM DISTANCE TO EXTEND STORM PIPE FROM ϕ ARV BOX SHALL BE 4 FEET.
4. SLOPE FILL MATERIAL TO DRAIN AWAY FROM AIR RELEASE VENT BOX AND INTO DITCH.

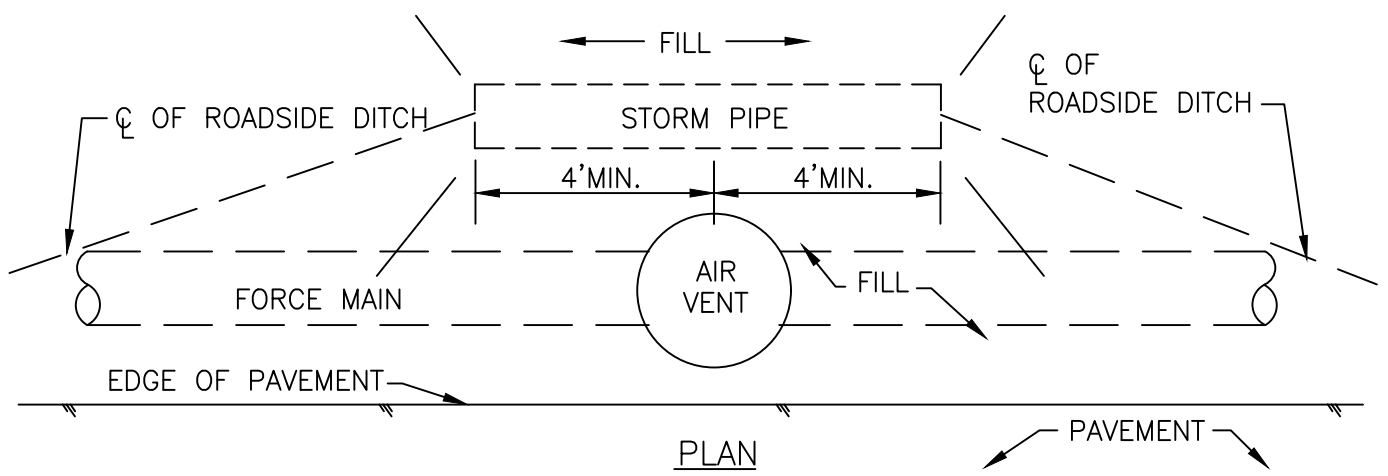

	STANDARD DESIGN DETAIL	DRAWING NO. 353
	ROADSIDE DITCH AIR VENT	SHEET 1 OF 1
		DATE 2/2024

NOTES

1. MACHINE ALL SEATING SURFACES ON BOTH COVER & FRAME
2. TOLERANCE TO BE ± 0.125 " FOR ALL DIMENSIONS.
3. CASTING TO BE SHOT BLASTED.
4. CASTING TO BE ASTM A-48 CLASS 30.
5. MINIMUM WEIGHTS:
FRAME- 114 LBS.
COVER- 50 LBS.
6. JACK UP RINGS NOT ACCEPTABLE.
7. SEE MASTER SPEC SECTION 01340 FOR AMERICAN IRON AND STEEL REQUIREMENT.

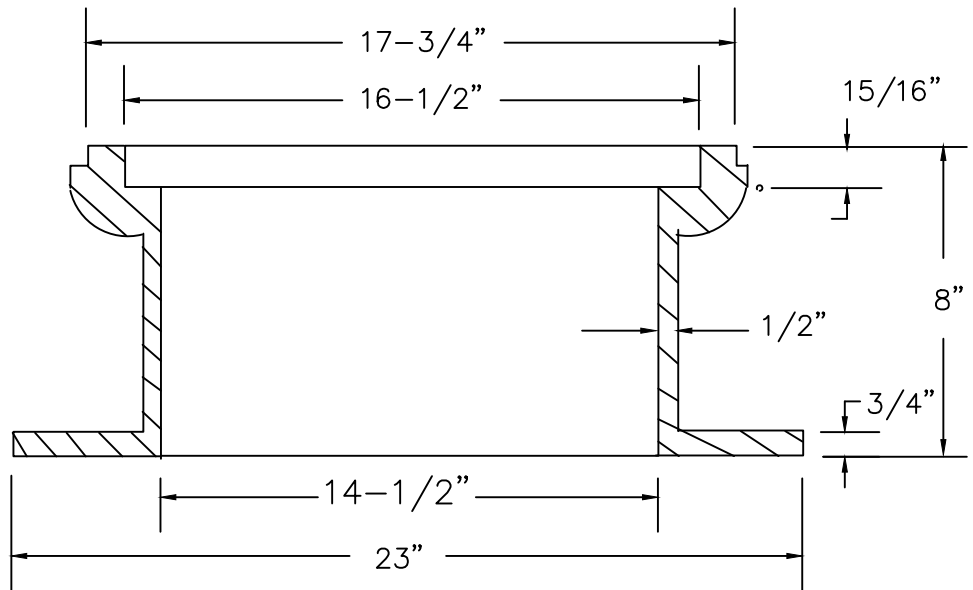
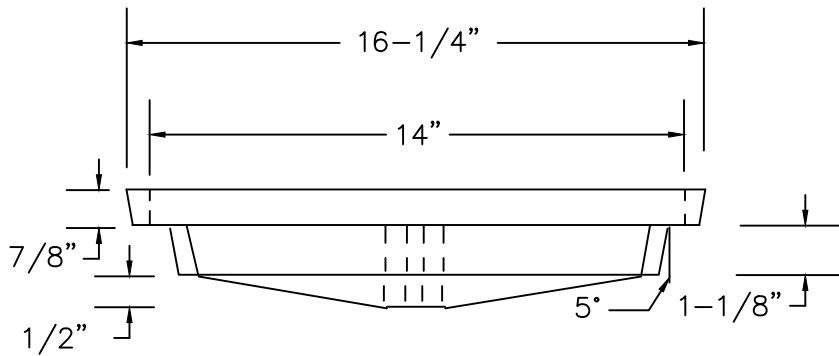
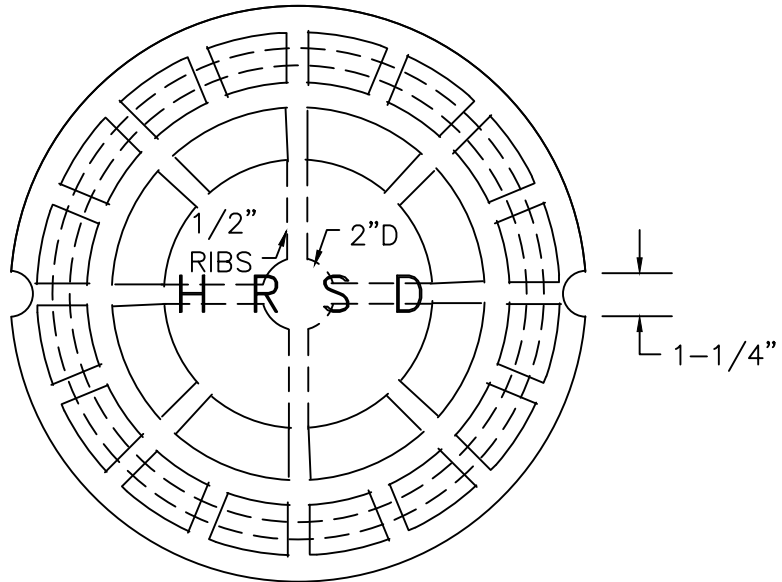

NOT TO SCALE



STANDARD DESIGN DETAIL

AIR VENT FRAME & COVER

DRAWING NO.

354

SHEET

1 OF 1

DATE

2/2024

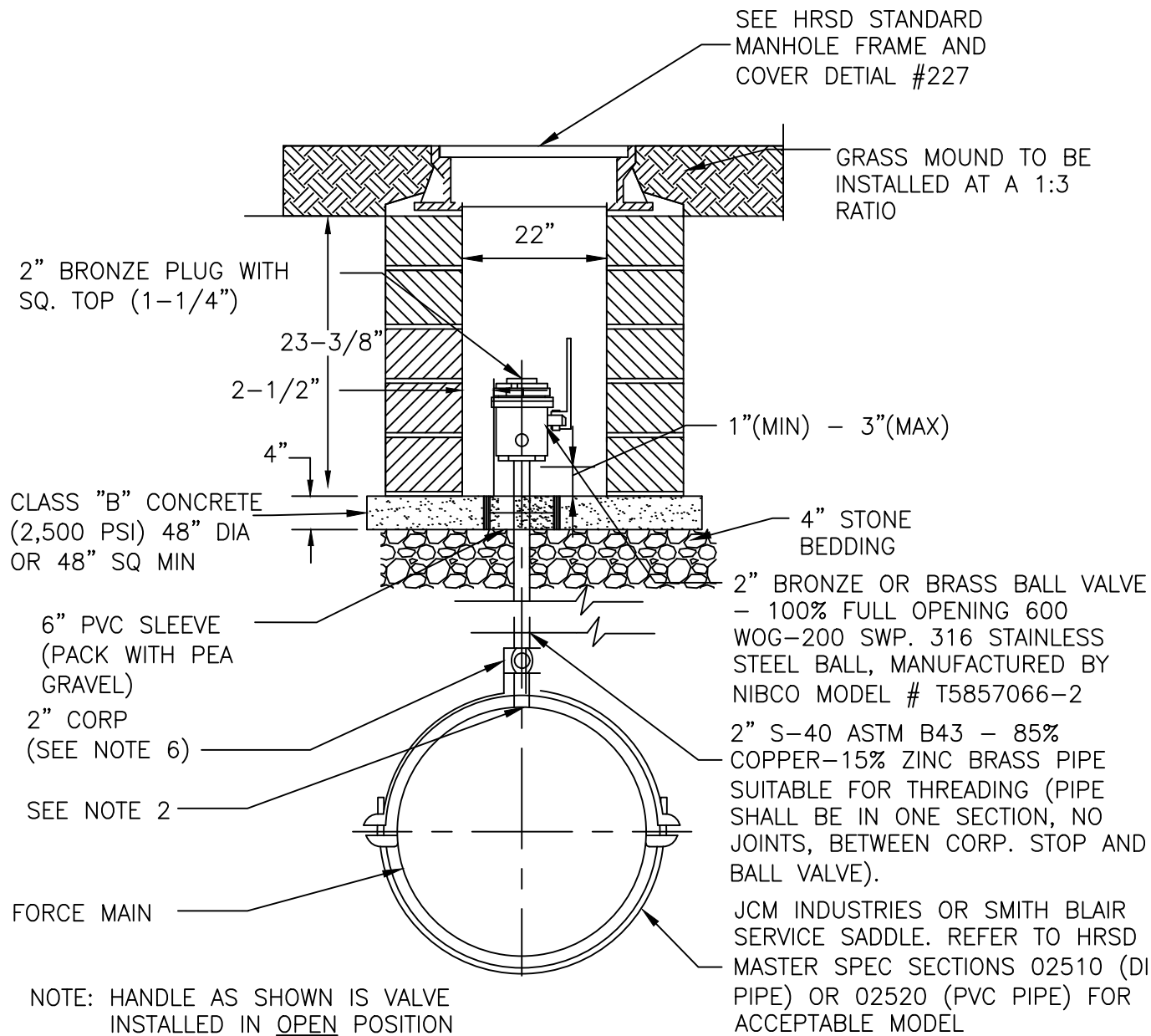

NOTES:

1. CONSTRUCT AIR VENT USING REQUIRED NUMBER OF COURSES OF HARD SOUND COMMON BRICK LAID ON EDGE OR CONCRETE ELEVATION RINGS AS MANUFACTURED BY NANSEMOND PRE-CAST CONCRETE CO, INC. MODEL AV-ER-CH AND AV-BS.
2. 2" TAP FOR AIR VENT SHALL BE STANDARD SADDLE TAP.
3. SERVICE SADDLE COATING SHALL BE FUSION BONDED EPOXY. SADDLE STRAPS AND HARDWARE SHALL BE STAINLESS STEEL. STAINLESS STEEL SHALL BE MINIMUM 304.
4. JACK UP RINGS BETWEEN THE FRAME AND COVER NOT ACCEPTABLE.
5. PARGE BRICK WORK OR CONCRETE ELEVATION RINGS WITH GROUT INSIDE AND OUT, CONTINUE ONTO CASTING.
6. MUELLER CATALOG #H10045N IS PREFERRED. REFER TO SPECIFICATION SECTION 02610 FOR ALLOWABLE ALTERNATIVES IF THE CONTRACTOR HAS DEMONSTRATED THE PREFERRED MODEL IS NOT AVAILABLE.

NOT TO SCALE

	STANDARD DESIGN DETAIL	DRAWING NO. 355
	AUTOMATIC AIR RELEASE VALVE BOX	SHEET 1 OF 1
		DATE 2/2024

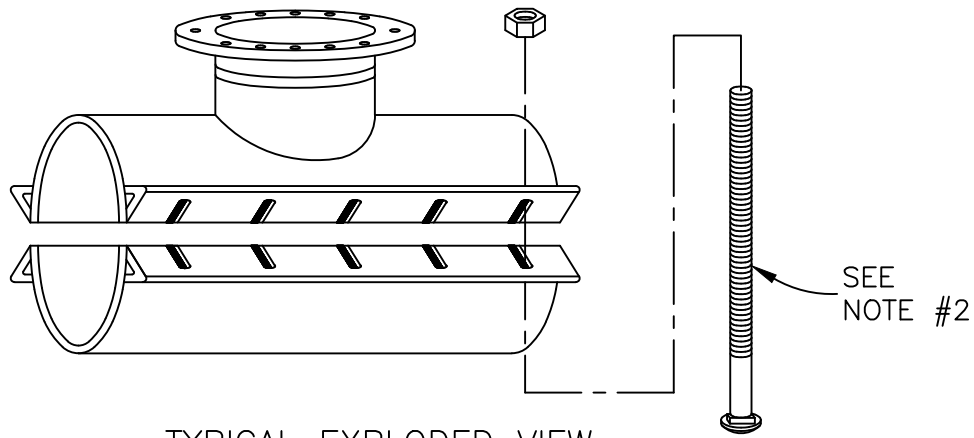

TYPICAL EXPLODED VIEW
SEE NOTE #1

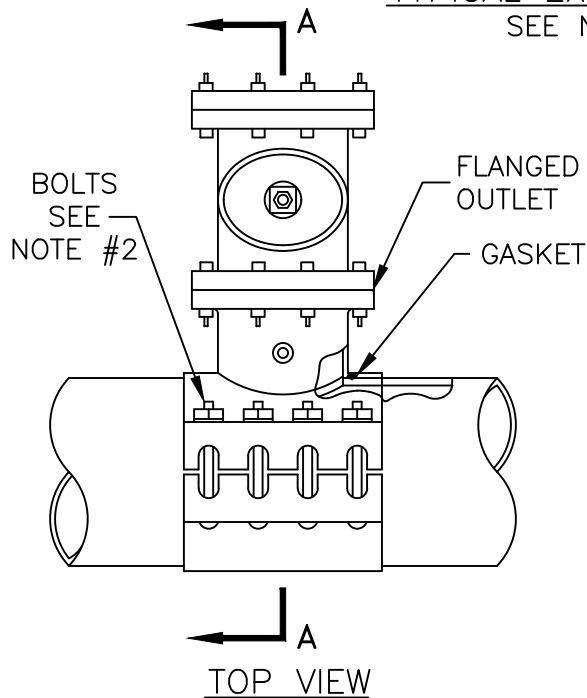

TOP VIEW

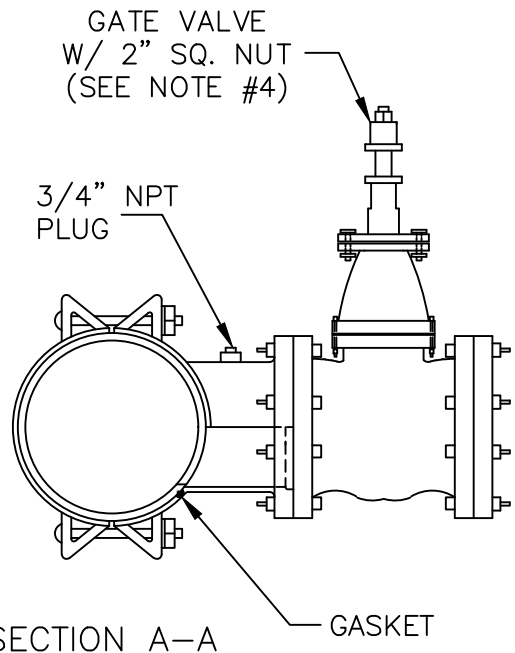

SECTION A-A

NOTES:

1. FULL BACK SADDLES ONLY, EXCEPT IN ACCORDANCE WITH PIPE MANUFACTURER'S RECOMMENDATIONS FOR SP-5 AND SP-12 (SEE H.R.S.D. STANDARD DESIGN DETAIL #377 - TAPPING SADDLE FOR CONC. CYLINDER PIPE).
2. THE NUMBER, SPACING, SIZE AND INSTALLATION OF BOLTS SHALL BE IN ACCORDANCE WITH SADDLE MANUFACTURER'S RECOMMENDATIONS.
3. CONTRACTOR SHALL SUPPLY TO HAMPTON ROADS SANITATION DISTRICT SYSTEMS ENGINEER THREE (3) CLEAR COPIES OF TAPPING SADDLE MANUFACTURER'S CATALOG CUT AND INSTALLATION INSTRUCTIONS 14 DAYS PRIOR TO INSTALLATION OF SADDLE.
4. GATE VALVE TO BE PROVIDED IN ACCORDANCE WITH SPECIFICATION 02610.
5. ALL BOLTS, NUTS AND WASHERS SHALL BE STAINLESS STEEL.
6. SADDLE COATING SHALL BE FUSION BONDED EPOXY.
7. TAPPING SADDLE MANUFACTURER SHALL BE SMITH-BLAIR STYLE 622 OR HRSD APPROVED EQUAL.
8. CONTRACTOR TO PERFORM EXPLORATORY EXCAVATIONS ON THE EXISTING FORCE MAIN TO CONFIRM PIPE OUTSIDE DIAMETER AND JOINT LOCATIONS. TAPPING SADDLE TO BE LOCATED A MIN. OF 4' FROM JOINT LOCATION OR AS APPROVED BY ENGINEER
NOT TO SCALE



STANDARD DESIGN DETAIL

TAPPING SADDLE FOR
CAST IRON PIPE, DUCTILE IRON, RC, & PVC PIPE

DRAWING NO.
376

SHEET
1 OF 1

DATE
2/2024

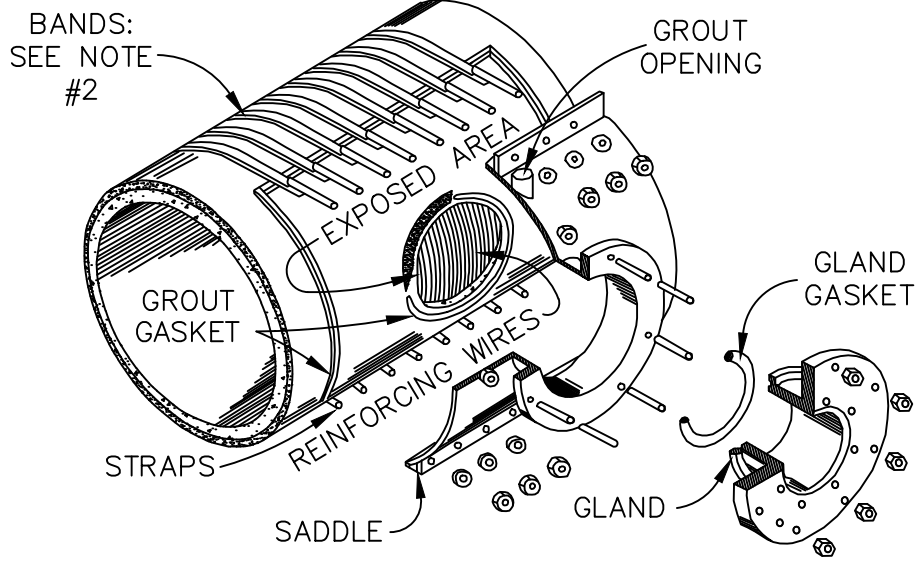

TYPICAL EXPLODED VIEW
SEE NOTE #1

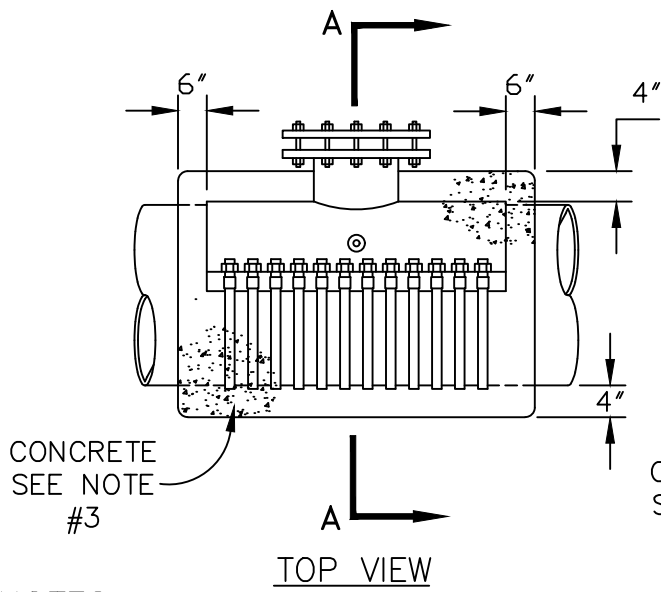

TOP VIEW

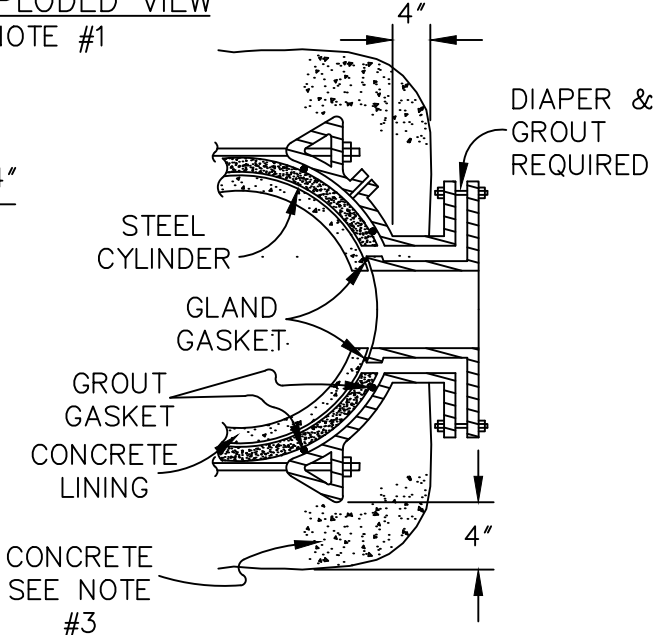

SECTION A-A

NOTES:

1. BANDED TAPPING SADDLES ONLY ACCEPTED ON SP-5 & SP-12 PIPE PER PIPE MANUFACTURER'S RECOMMENDATIONS (SEE STANDARD DESIGN DETAIL #12 - STANDARD TAPPING SADDLE FOR CAST IRON PIPE, DUCTILE IRON, RC, & PVC PIPE).
2. THE NUMBER, SPACING, SIZE AND INSTALLATION OF BANDS SHALL BE IN ACCORDANCE WITH SADDLE MANUFACTURER'S RECOMMENDATIONS.
3. ALL TAPPING SADDLES SHALL RECEIVE 4", 3000 PSI CONCRETE COVER WITH 6"x6"x6" GAUGE WELDED WIRE REINFORCEMENT.
4. CONTRACTOR SHALL SUPPLY TO HAMPTON ROADS SANITATION DISTRICT SYSTEMS ENGINEER THREE (3) CLEAR COPIES OF TAPPING SADDLE MANUFACTURER'S CATALOG CUT AND INSTALLATION INSTRUCTIONS 14 DAYS PRIOR TO INSTALLATION OF SADDLE.
5. TAPPING SADDLE MANUFACTURER SHALL BE SMITH-BLAIR STYLE 625 OR JCM INDUSTRIES STYLE 415.

NOT TO SCALE



STANDARD DESIGN DETAIL

TAPPING SADDLE FOR CONCRETE CYLINDER PIPE

DRAWING NO. 377
SHEET 1 OF 1
DATE 2/2024

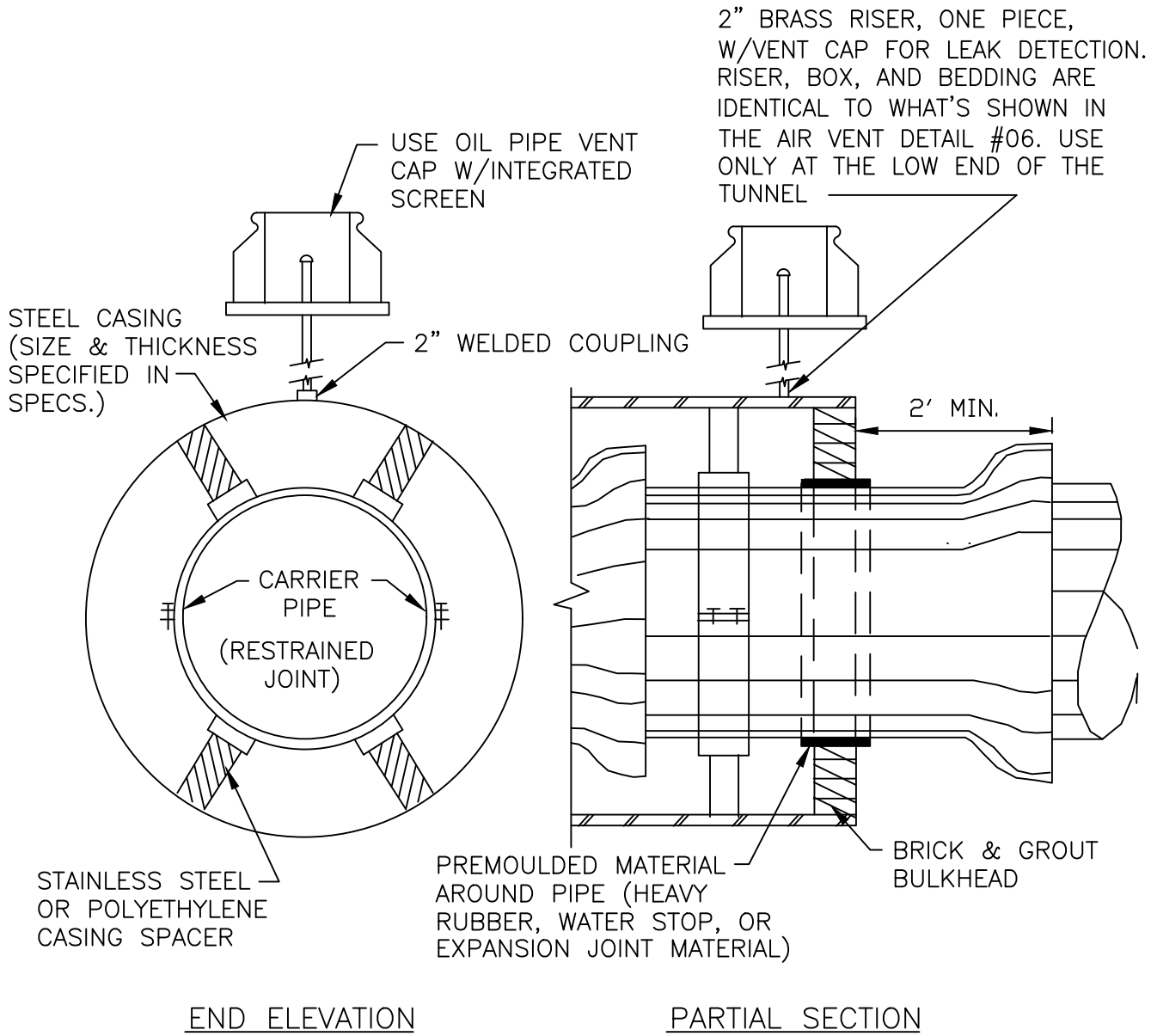

NOTE: INSTALL CASING PIPE AS SHOWN ON DRAWINGS OR MIN. 4' BEYOND EDGE OF PAVEMENT.

NOT TO SCALE

	STANDARD DESIGN DETAIL	DRAWING NO. 378A
	STEEL PIPE CASING	SHEET 1 OF 2
		DATE 2/2024

NOTES:

A. STAINLESS STEEL SPACERS

SPACERS SHALL BE BOLT ON STYLE WITH A TWO PIECE SHELL MADE FROM T-304 STAINLESS STEEL OF A MINIMUM 14 GAUGE THICKNESS. THE SHELL SHALL BE LINED WITH A RIBBED P.V.C. SHEET OF A 0.090" THICKNESS THAT OVERLAPS THE EDGES. RUNNERS MADE FROM UHMW POLYMER, SHALL BE ATTACHED TO RISERS AT APPROPRIATE POSITIONS TO PROPERLY LOCATE THE CARRIER WITHIN THE CASING AND TO EASE INSTALLATION. RISERS TO BE MADE FROM T-304 STAINLESS STEEL OF A MINIMUM 14 GAUGE THICKNESS AND SHALL BE ATTACHED TO THE SHELL BY MIG WELDING. ALL WELDS SHALL BE FULLY PASSIVATED. ALL FASTENERS SHALL BE MADE FROM T-304 STAINLESS STEEL CASING SPACERS SHALL BE MODEL CCS AS MANUFACTURED BY CASCADE WATERWORKS MANUFACTURING COMPANY OF YORKVILLE, IL. OR APPROVED EQUAL.

B. HIGH DENSITY POLYETHYLENE

SPACERS SHALL BE PROJECTION TYPE, TOTALLY NON-METALLIC CONSTRUCTED OF PREFORMED SECTIONS OF HIGH-DENSITY POLYETHYLENE AND ISO 9002 CERTIFIED FOR STRENGTH AND QUALITY. SPACERS SHALL PROVIDE SUPPORT AROUND THE PERIPHERY OF THE PIPE. THE MINIMUM NUMBER OF PROJECTIONS AROUND THE CIRCUMFERENCE SHALL TOTAL THE NUMBER OF PIPE DIAMETER INCHES. SPACERS SHALL USE DOUBLE BACK TAPE TO FASTEN TIGHTLY ONTO THE CARRIER PIPE. SPACER SPAN SHALL BE IN ACCORDANCE WITH THE MANUFACTURER'S RECOMMENDATIONS TO PREVENT SAGGING OF THE PIPE. THE MAXIMUM LOAD SHALL NOT EXCEED MANUFACTURER'S RECOMMENDATIONS. SPACERS SHALL HAVE MINIMUM HEIGHT THAT CLEARS THE PIPE BELL OR AS OTHERWISE INDICATED ON THE PLANS. SPACERS SHALL BE MANUFACTURED BY RACI SPACERS NORTH AMERICA INC. OR APPROVED EQUAL.

C. SPACER WIDTH AND PLACEMENT INTERVALS

IN ALL INSTANCES SPACER SHOULD BE PLACED SO AS TO SUPPORT THE CARRIER WITHIN 2' OF THE ENDS OF THE PIPE. CONSULT PIPE MANUFACTURER FOR RECOMMENDATIONS ON SPACER WIDTH AND ADDITIONAL PLACEMENT INTERVALS.

	STANDARD DESIGN DETAIL	DRAWING NO. 378B
		SHEET 2 OF 2
	STEEL PIPE CASING	DATE 2/2024

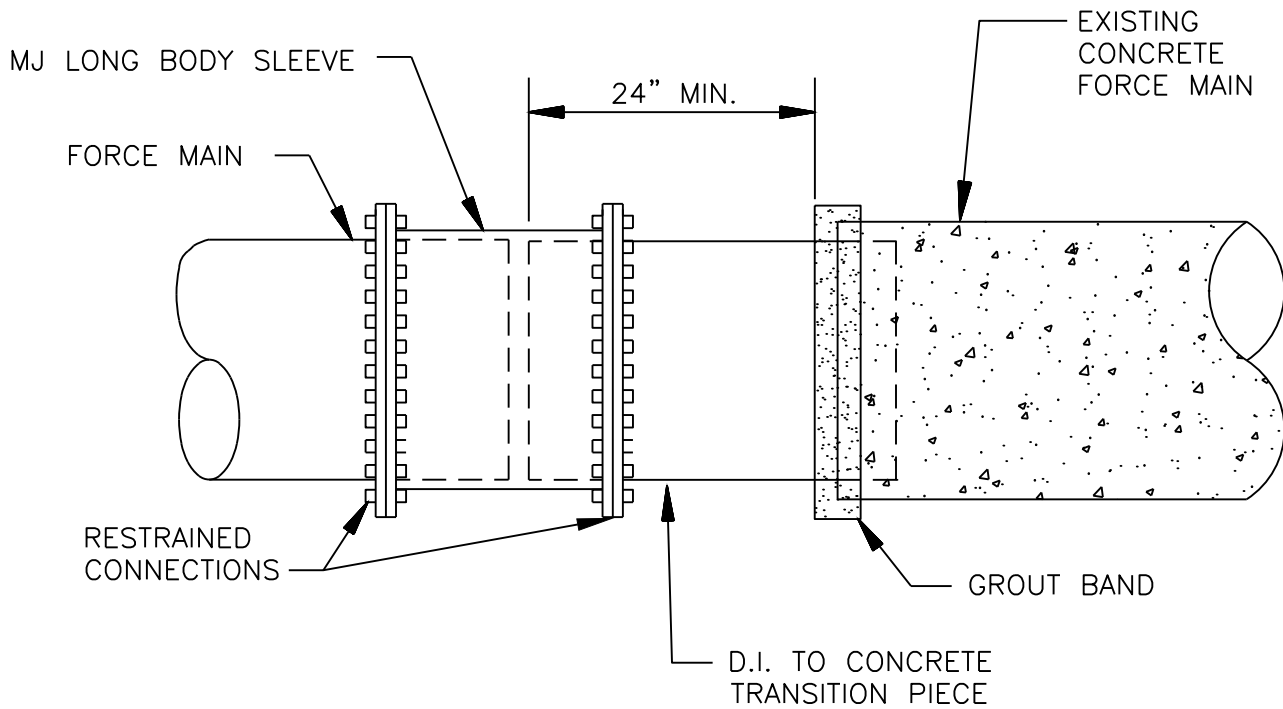

A	B	M.J.S. O.D.
16"	30.0"	17.4"
18"	30.0"	19.5"
20"	30.0"	21.6"
24"	30.0"	25.8"
30"	30.0"	32.0"
36"	30.0"	38.3"
42"	30.0"	44.5"
48"	30.0"	50.8"

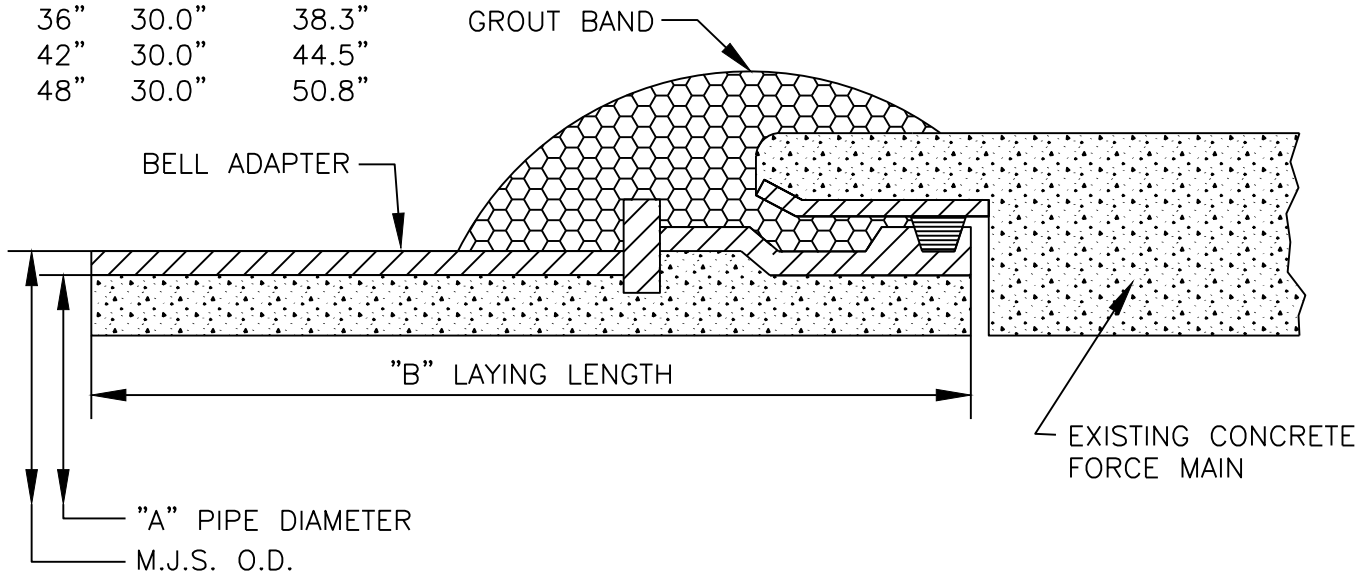

NOT TO SCALE



STANDARD DESIGN DETAIL

MALE TRANSITION ADAPTER FROM DUCTILE IRON
M.J. SPIGOT TO CONCRETE PIPE

DRAWING NO.
379

SHEET
1 OF 1

DATE
2/2024

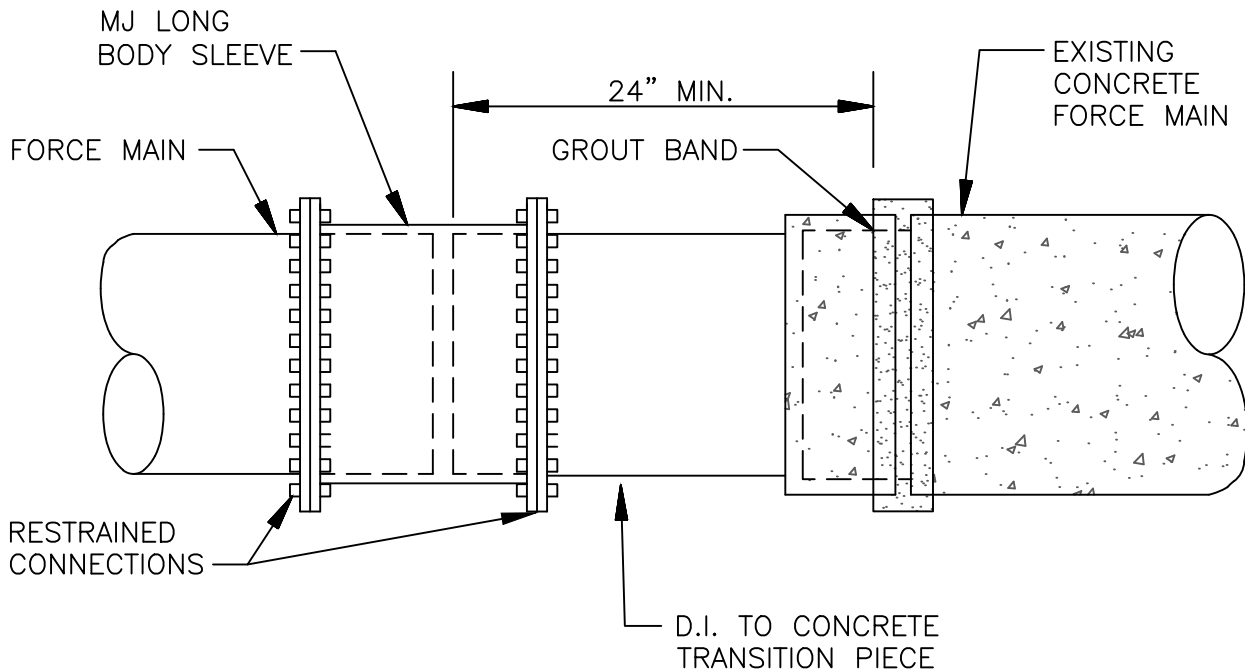

A	B	M.J.S. O.D.
16"	25.5"	17.4"
18"	25.5"	19.5"
20"	25.5"	21.6"
24"	25.5"	25.8"
30"	25.5"	32.0"
36"	25.5"	38.3"
42"	25.5"	44.5"
48"	25.5"	50.8"

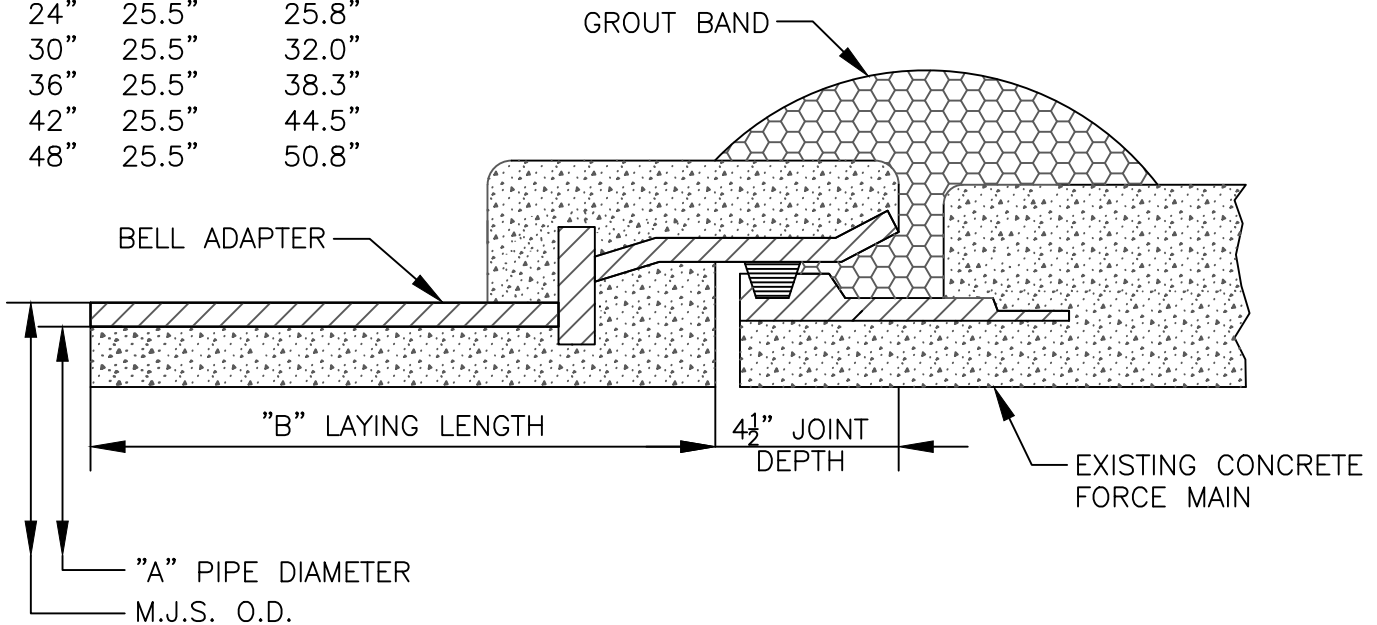

NOT TO SCALE



STANDARD DESIGN DETAIL

FEMALE TRANSITION ADAPTER FROM DUCTILE IRON
M.J. SPIGOT TO CONCRETE PIPE

DRAWING NO.	380
SHEET	1 OF 1
DATE	2/2024

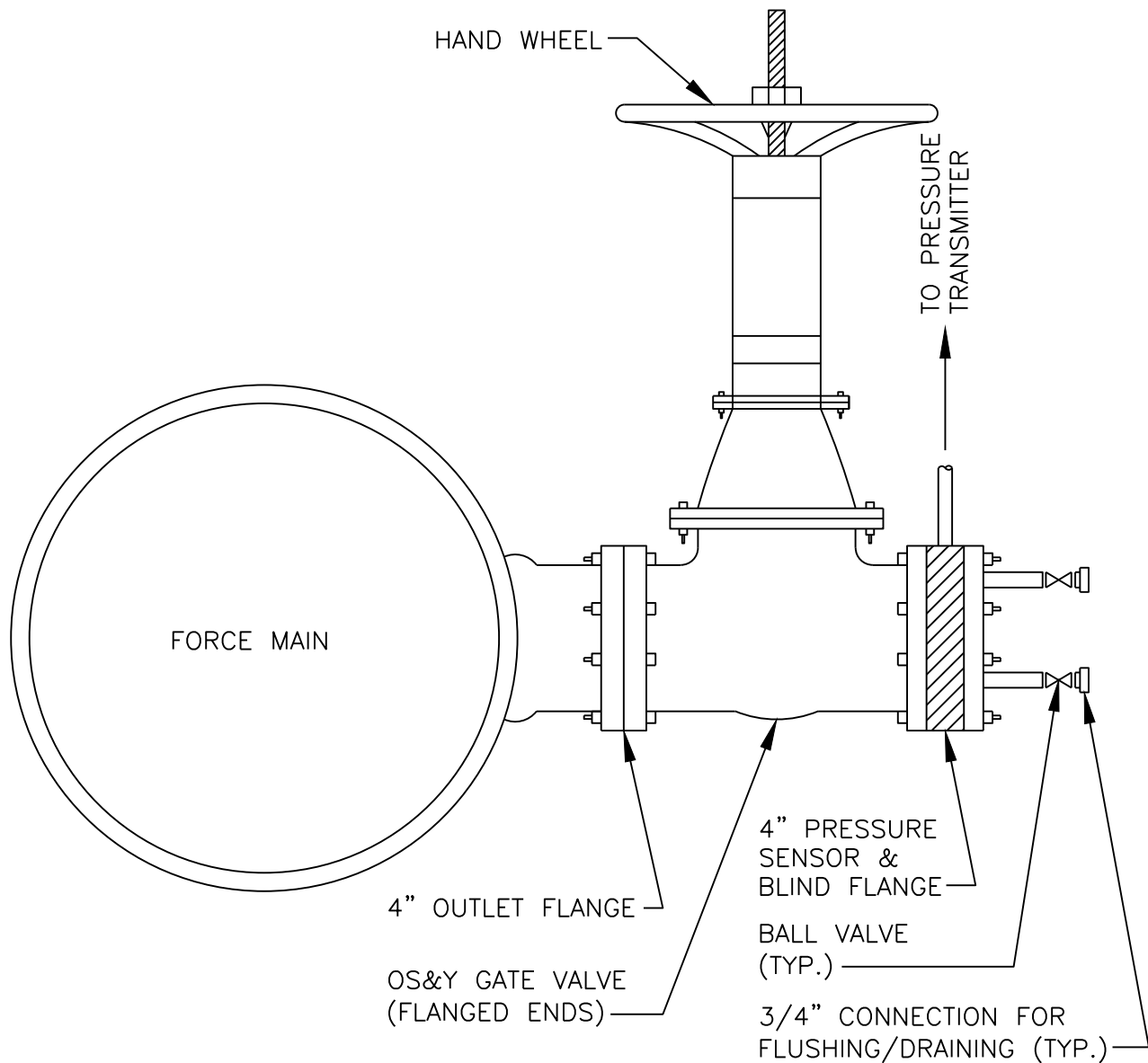

NOTES:

1. THE CENTERLINE OF THE 4" OUTLET FLANGE SHALL BE LOCATED AT THE 3 O'CLOCK POSITION.

NOT TO SCALE

	STANDARD DESIGN DETAIL	DRAWING NO. 381
	PRESSURE SENSOR INSTALLATION	SHEET 1 OF 1
		DATE 2/2024

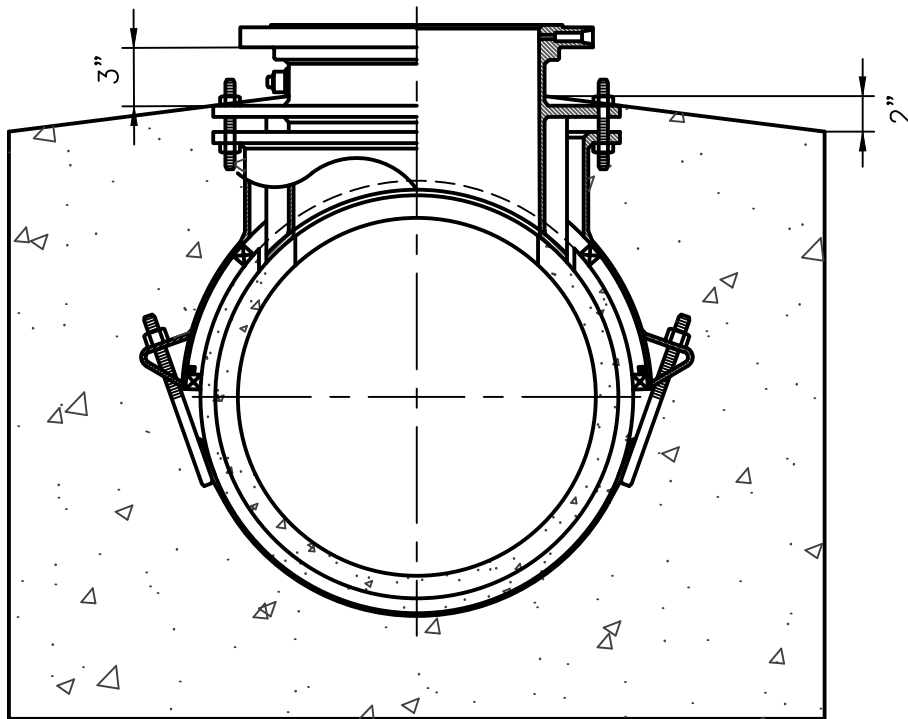

NOTES:

1. CONCRETE BLOCK, FOOTER, AND CONCRETE RELATED ITEMS SHALL BE DETERMINED BY ENGINEER.
2. THIS DETAIL IS TO PROVIDE THE CONTRACTOR THE PROPER DIMENSIONS FOR CONSTRUCTING THE TOP OF THE CONCRETE BLOCK.

NOT TO SCALE



STANDARD DESIGN DETAIL

LINE-STOP CONCRETE BLOCK FOR CONCRETE PIPE

DRAWING NO. 382
SHEET 1 OF 1
DATE 2/2024

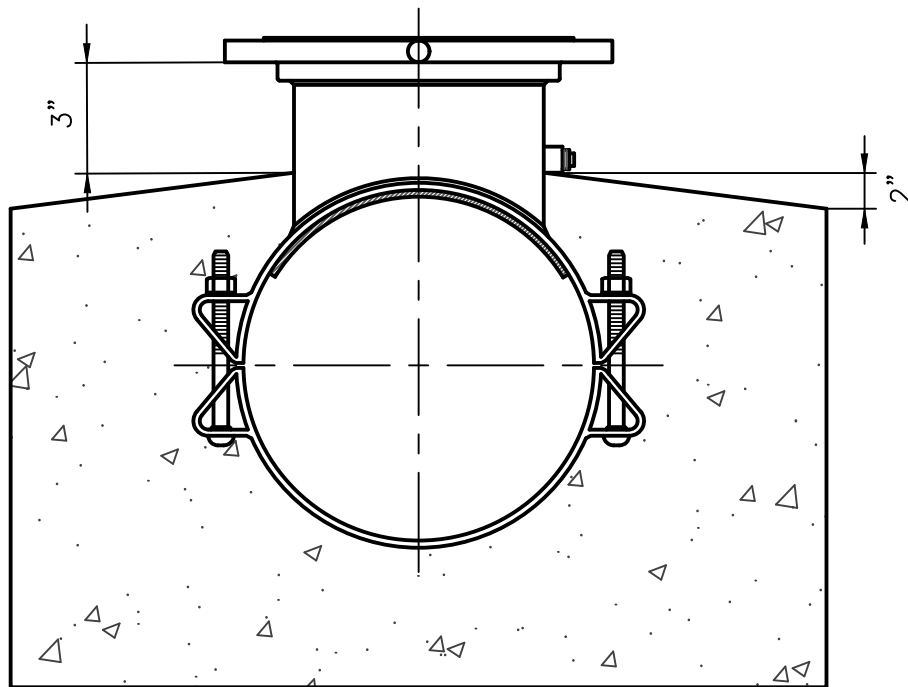

NOTES:

1. CONCRETE BLOCK, FOOTER, AND CONCRETE RELATED ITEMS SHALL BE DETERMINED BY ENGINEER.
2. THIS DETAIL IS TO PROVIDE THE CONTRACTOR THE PROPER DIMENSIONS FOR CONSTRUCTING THE TOP OF THE CONCRETE BLOCK.

NOT TO SCALE



STANDARD DESIGN DETAIL

LINE-STOP CONCRETE BLOCK FOR
DUCTILE IRON PIPE

DRAWING NO. 383
SHEET 1 OF 1
DATE 2/2024

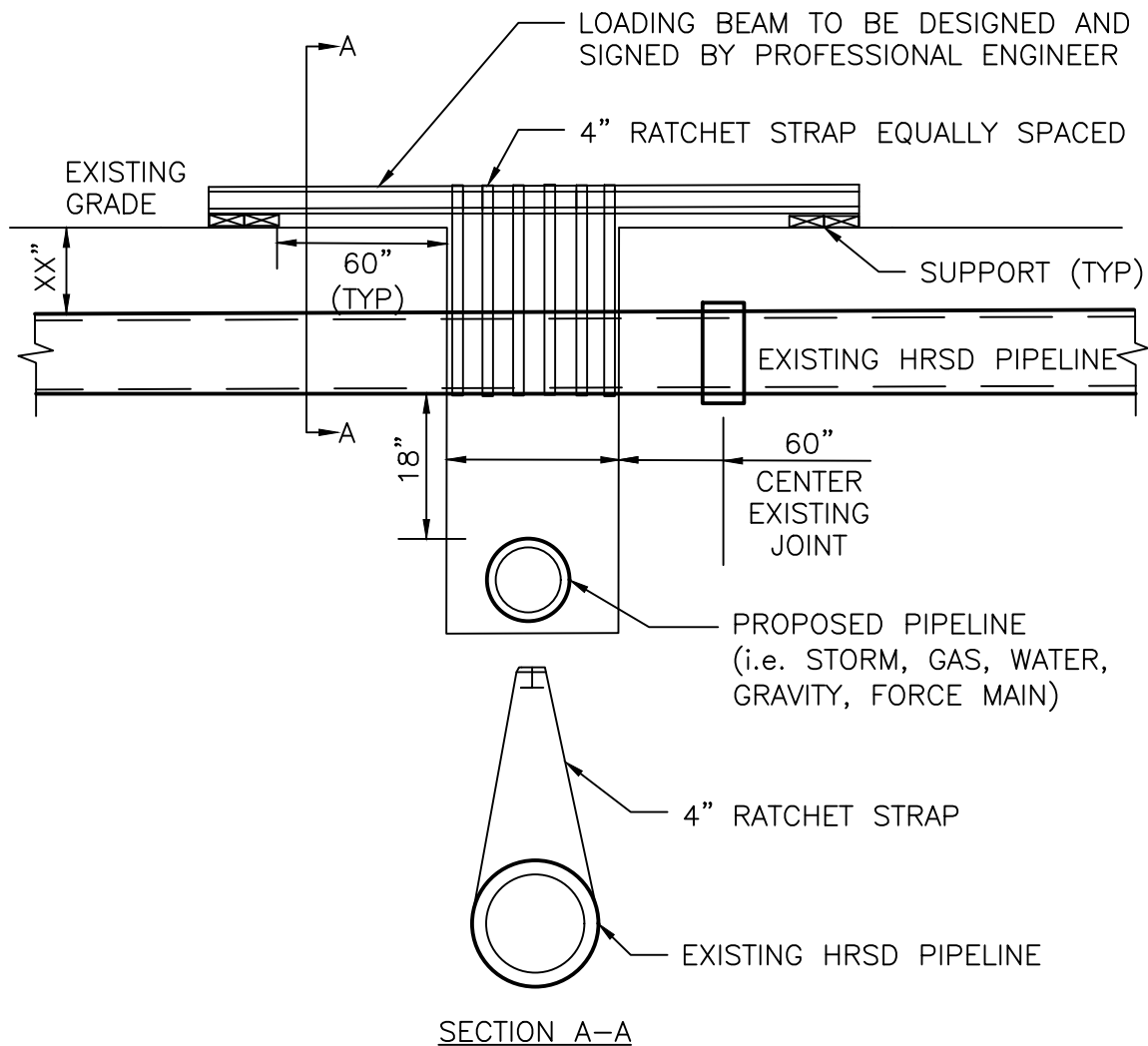

NOTES:

1. CONTRACTOR / DEVELOPER / OWNER TO SUBMIT DETAIL FOR REVIEW AND APPROVAL BY HRSD.
2. PROFESSIONAL ENGINEER STAMP IS REQUIRED FOR THE DETAIL TO BE APPROVED.
3. PROPOSED PIPELINE SHALL BE INSTALLED WITH FULL LENGTH OF PIPE AND MID-SECTION AT THE CROSSING. PIPE JOINTS AT THE CROSSING WILL NOT BE PERMITTED.

NOT TO SCALE



STANDARD DESIGN DETAIL

SUPPORT CROSSING FOR FORCE MAIN OR GRAVITY MAIN

DRAWING NO.

386

SHEET

1 OF 1

DATE

2/2024