

- NOTES:**
1. MATERIAL, CAST IRON, GRADE TO BE SPECIFIED ON PURCHASE ORDER.
 2. ALL RADII SHALL BE $\frac{1}{16}$ " MINIMUM.
 3. ESTIMATED WEIGHT 37#.

NOT TO SCALE

	STANDARD DESIGN DETAIL	DRAWING NO. 500A
	CATHODIC PROTECTION TEST STATION AND TERMINAL BOARD WIRING	SHEET 1 OF 2
		DATE 7/2026

0.01 OHM 8 AMPERE
MILLIVOLT SHUNT

REMOVABLE
TERMINAL BOARD

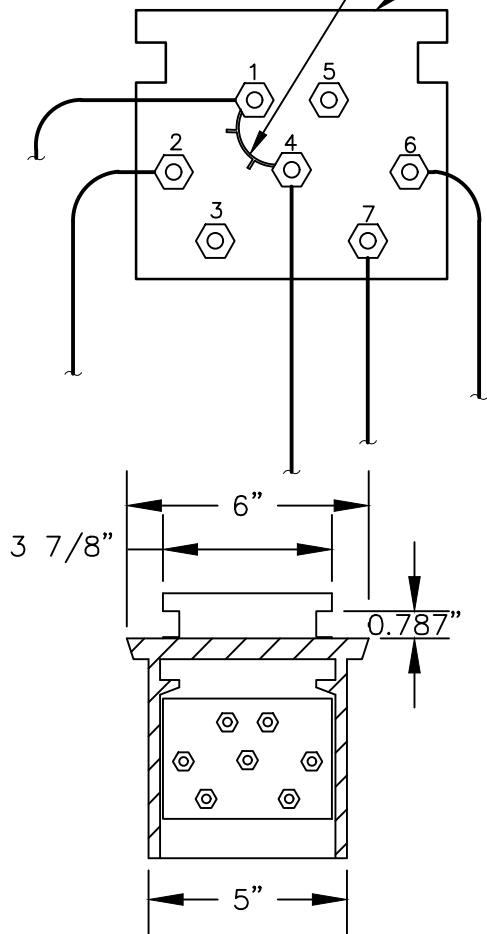

TERMINAL BOARD INSIDE LID

WIRE INSULATION DETAILS				
SHUNT	DESCRIPTION	SIZE #	COLOR THEME	INSULATION
1	ANODE HEADER	#10	RED	THHN
2	ANODE HEADER	#10	RED	THHN
4	STRUCTURE WIRE TO PIPELINE	#10	BLACK	THHN
6	COPPER COPPER SULFATE REFERENCE ELECTRODE	#14	BLUE	HMWPE
7	STRUCTURE WIRE TO PIPELINE	#10	BLACK	THHN

NOTE:
TEST BOARD SHOULD NOT BE CONNECTED TO THE UNDER SIDE OF THE TEST STATION LID.

NOT TO SCALE



STANDARD DESIGN DETAIL

CATHODIC PROTECTION TEST STATION
AND TERMINAL BOARD WIRING

DRAWING NO.
500B

SHEET
2 OF 2

DATE
7/2026

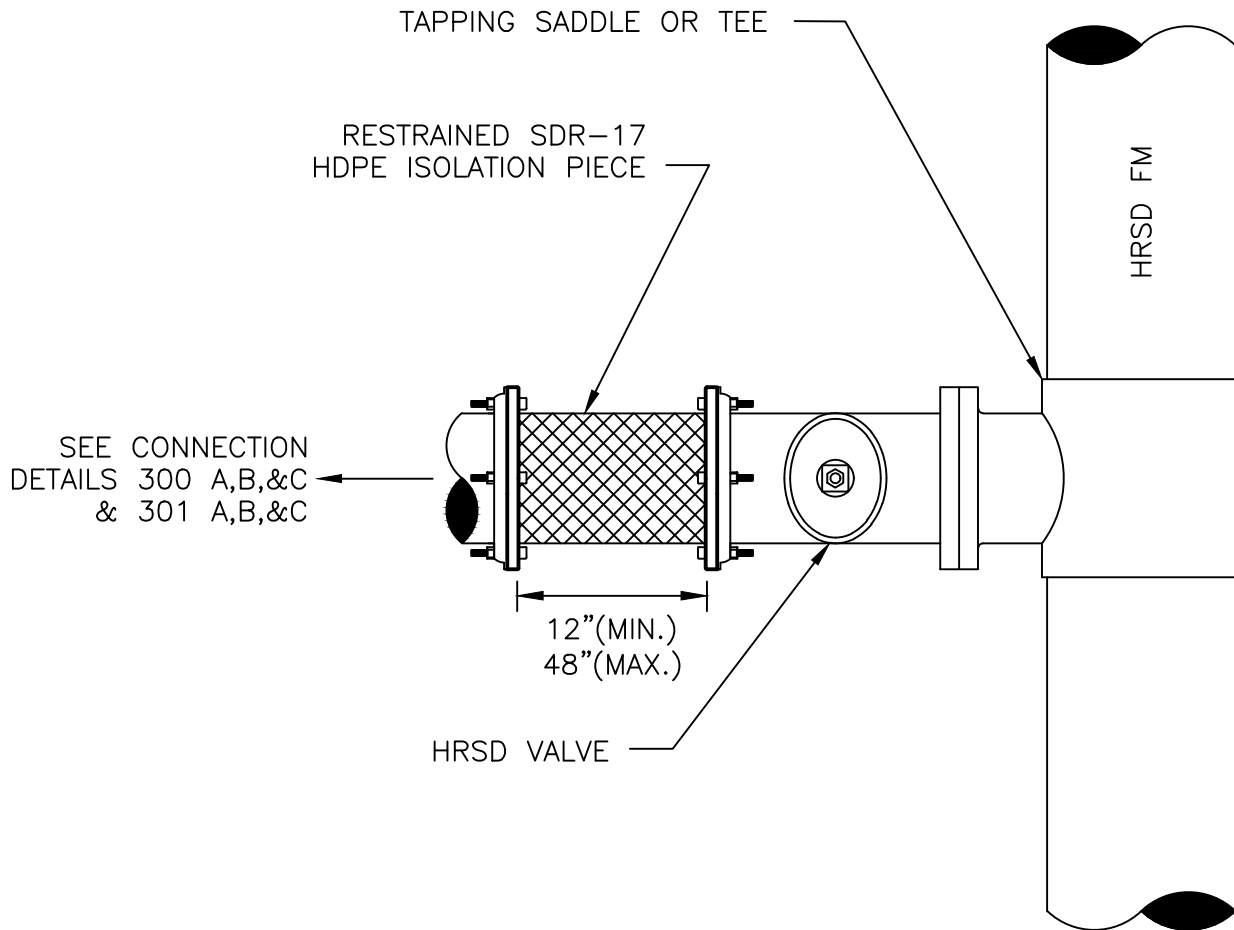

NOTES:

1. LOCALITY TO OWN ALL PIPING, FITTINGS, VALVES, AND CATHODIC PROTECTION SYSTEMS UPSTREAM OF HRSD VALVE.
2. ISOLATION PIECE SHALL BE APPROXIMATELY 24" LONG.

NOT TO SCALE



STANDARD DESIGN DETAIL

CATHODIC PROTECTION ISOLATION DETAIL

DRAWING NO.
501

SHEET
1 OF 1

DATE
7/2026

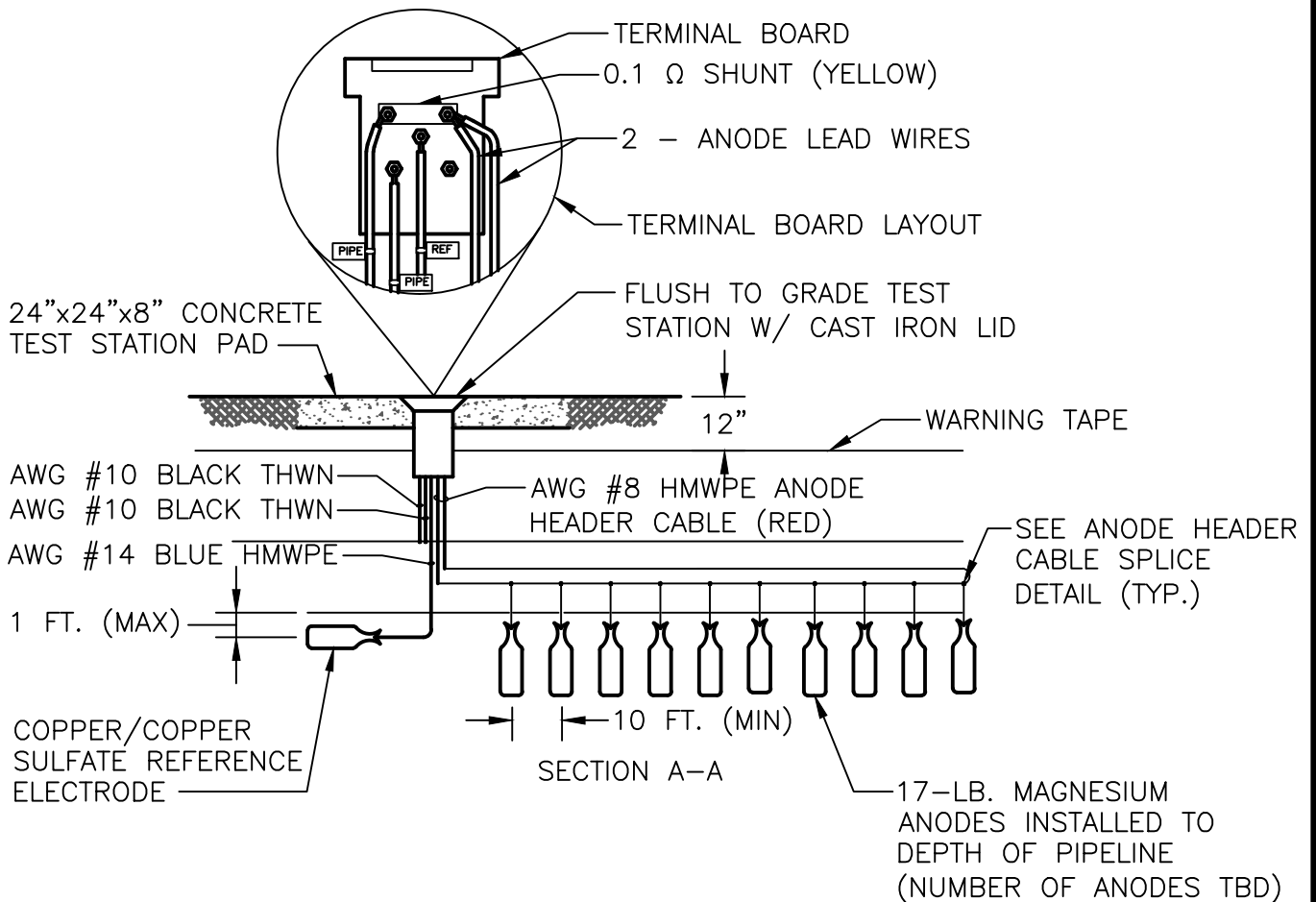
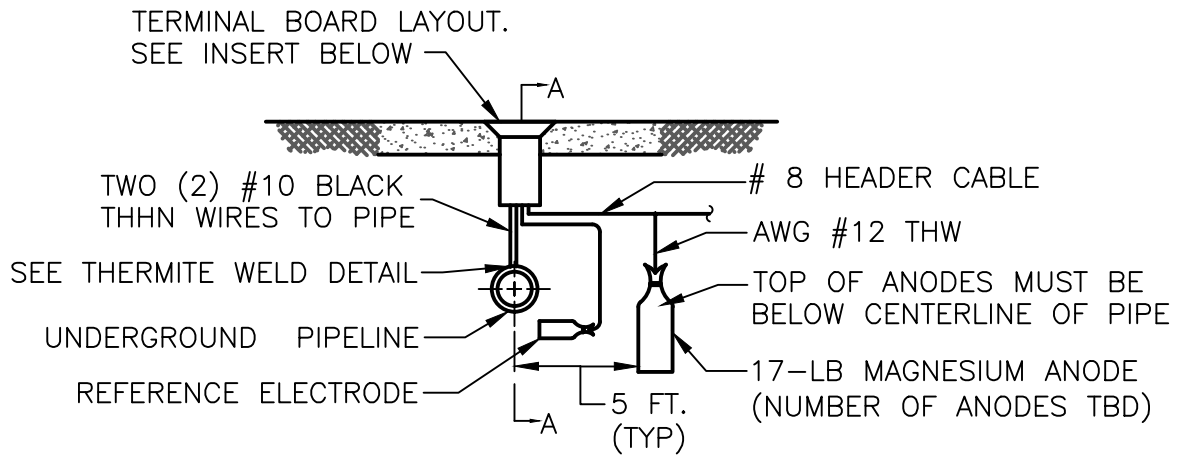

NOT TO SCALE



STANDARD DESIGN DETAIL

ANODE TEST STATION

DRAWING NO.
502

SHEET
1 OF 1

DATE
7/2026

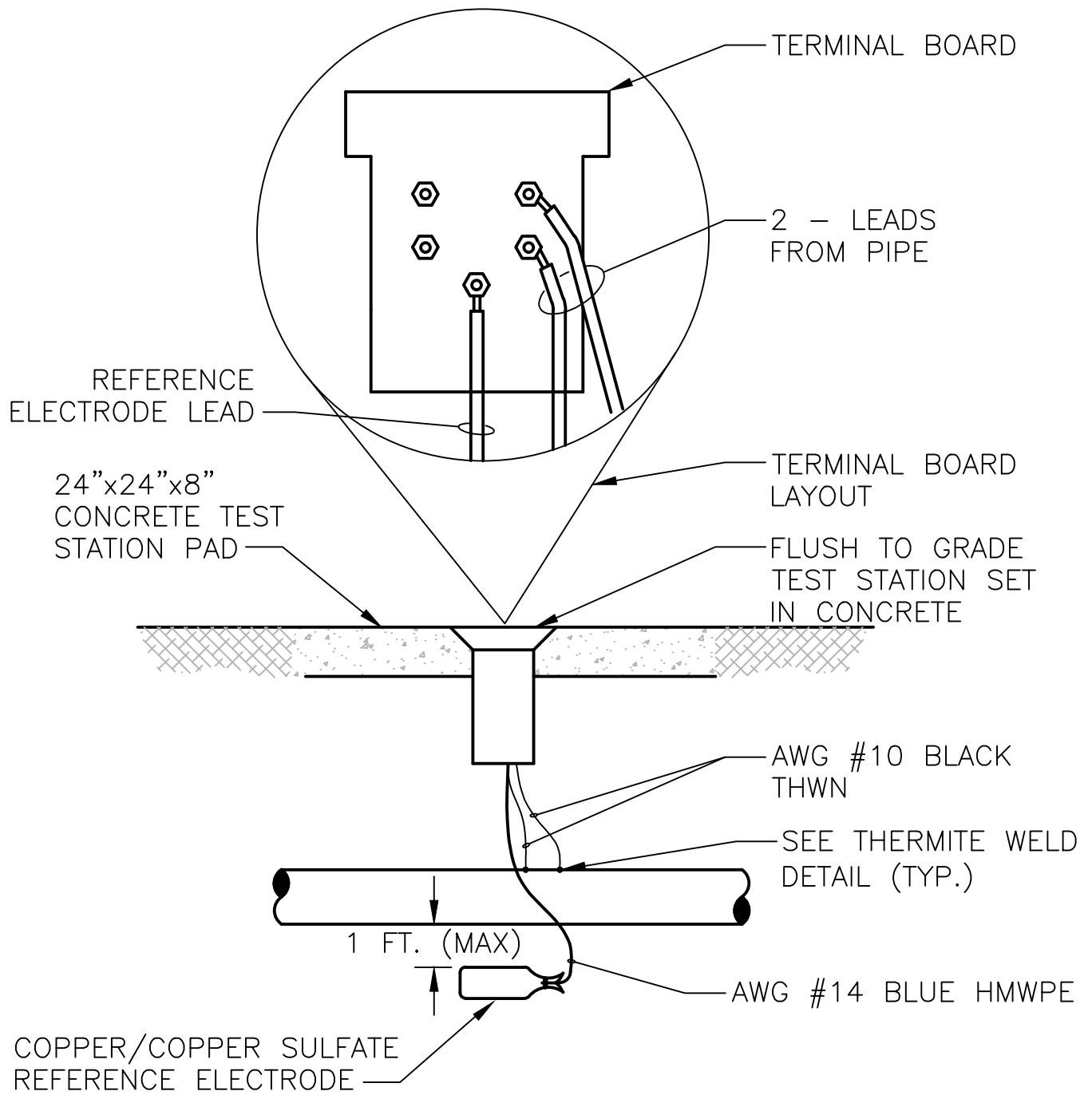

NOTES:

1. WHEN TEST STATION IS OUT OF THE ROAD, USE A GREEN RISER PROTECTED BY BOLLARDS.

NOT TO SCALE



STANDARD DESIGN DETAIL

MONITORING TEST STATION

DRAWING NO.
503

SHEET
1 OF 1

DATE
7/2026

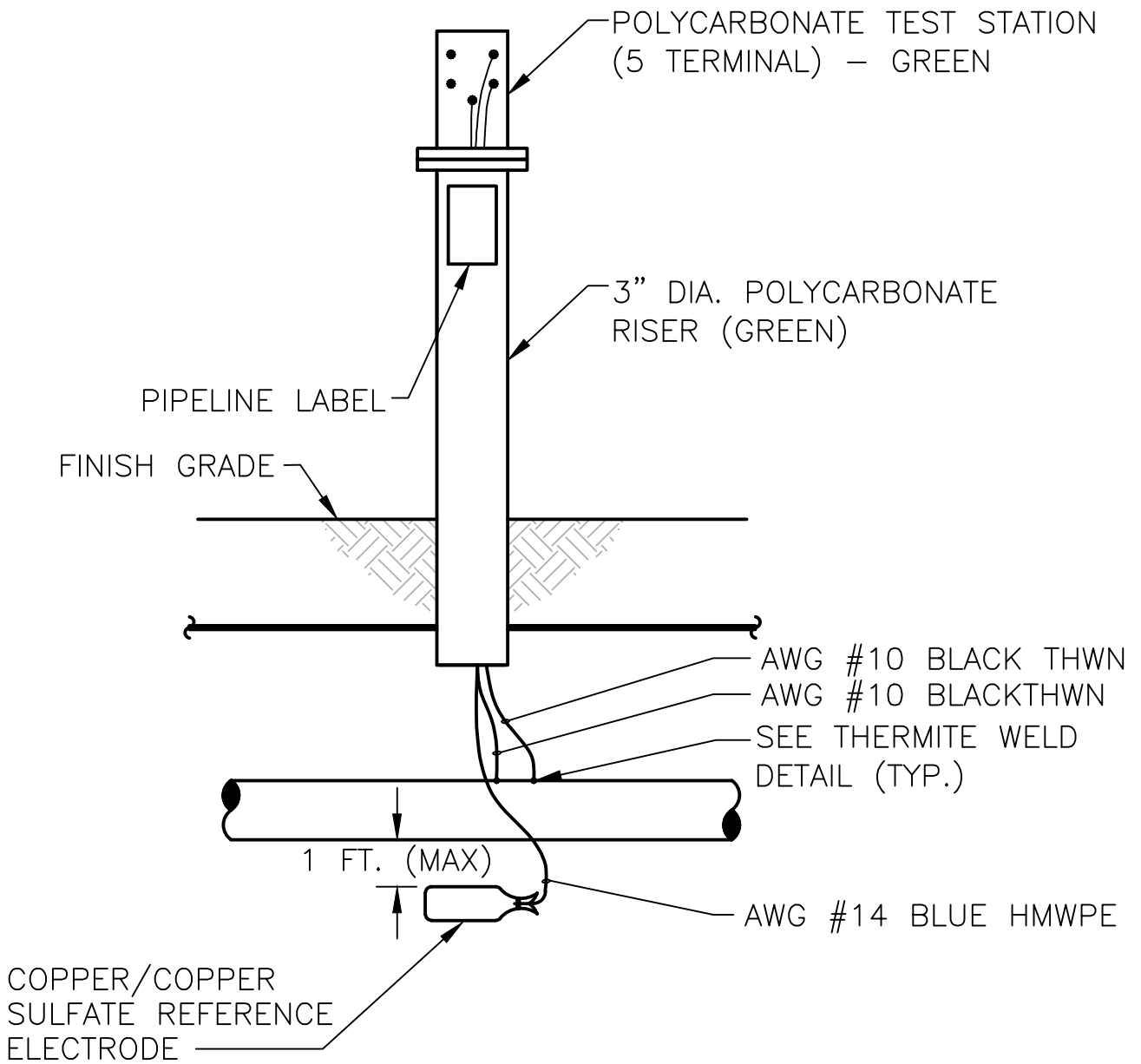

NOTES:

1. WHEN TEST STATION IS OUT OF THE ROAD, USE A GREEN RISER PROTECTED BY BOLLARDS.

NOT TO SCALE



STANDARD DESIGN DETAIL

MONITORING TEST STATION (WITH RISER)

DRAWING NO.
504

SHEET
1 OF 1

DATE
7/2026

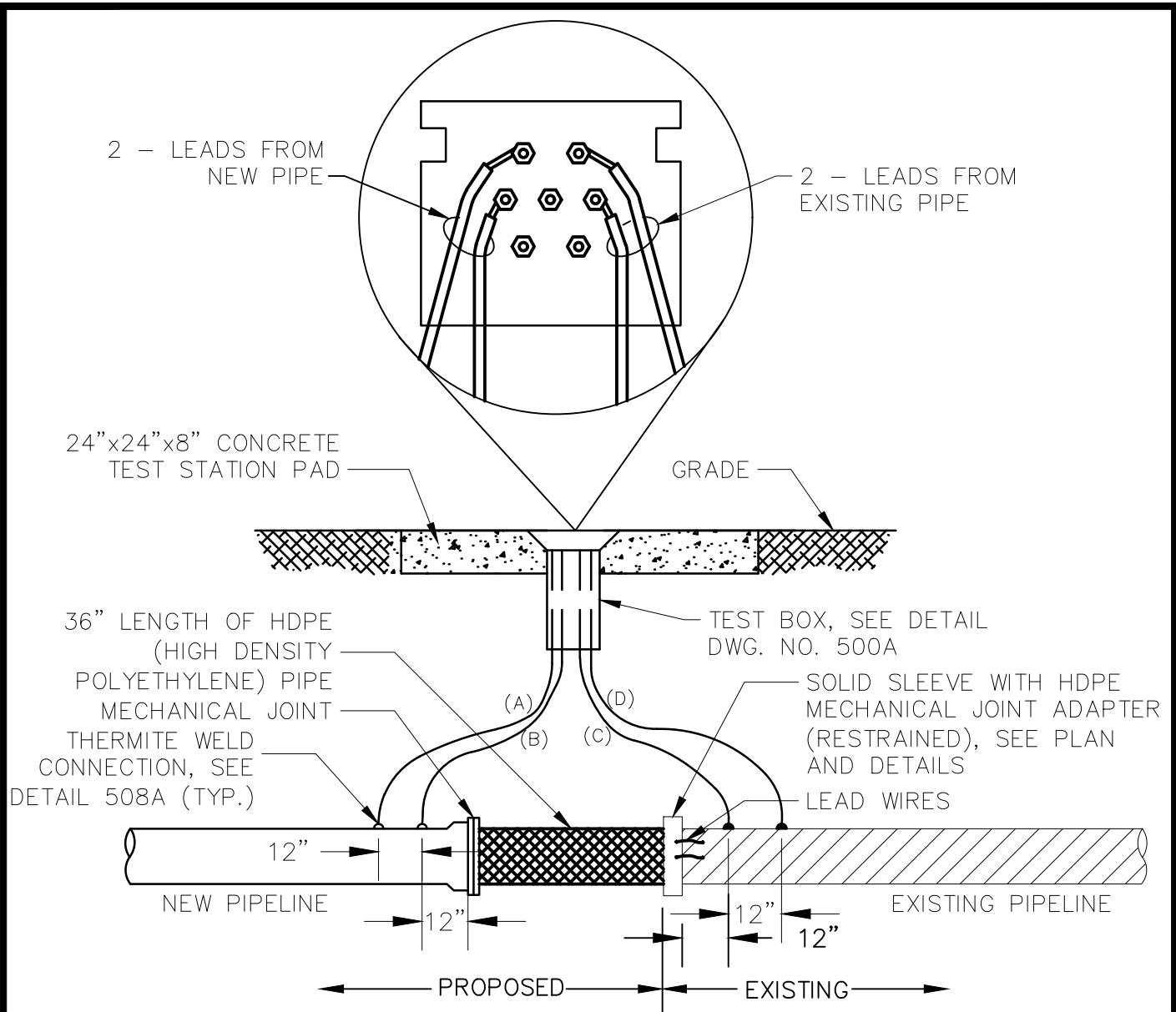

NOTES:

1. WHEN TEST STATION IS OUT OF THE ROAD, USE A GREEN RISER PROTECTED BY BOLLARDS.
2. HDPE SHALL BE DR-17, UNLESS NOTED OTHERWISE ON PLANS OR SPECIFICATIONS.

WIRE INSULATION DETAILS				
WIRE	DESCRIPTION	SIZE #	COLOR THEME	INSULATION
A	NEW PIPE TEST LEAD	#10	WHITE	THHN
B	NEW PIPE TEST LEAD	#10	WHITE	THHN
C	EXISTING PIPE TEST LEAD	#10	BLACK	THHN
D	EXISTING PIPE TEST LEAD	#10	BLACK	THHN

NOT TO SCALE



STANDARD DESIGN DETAIL

ISOLATION FLANGE TEST STATION

DRAWING NO.
505

SHEET
1 OF 1

DATE
7/2026

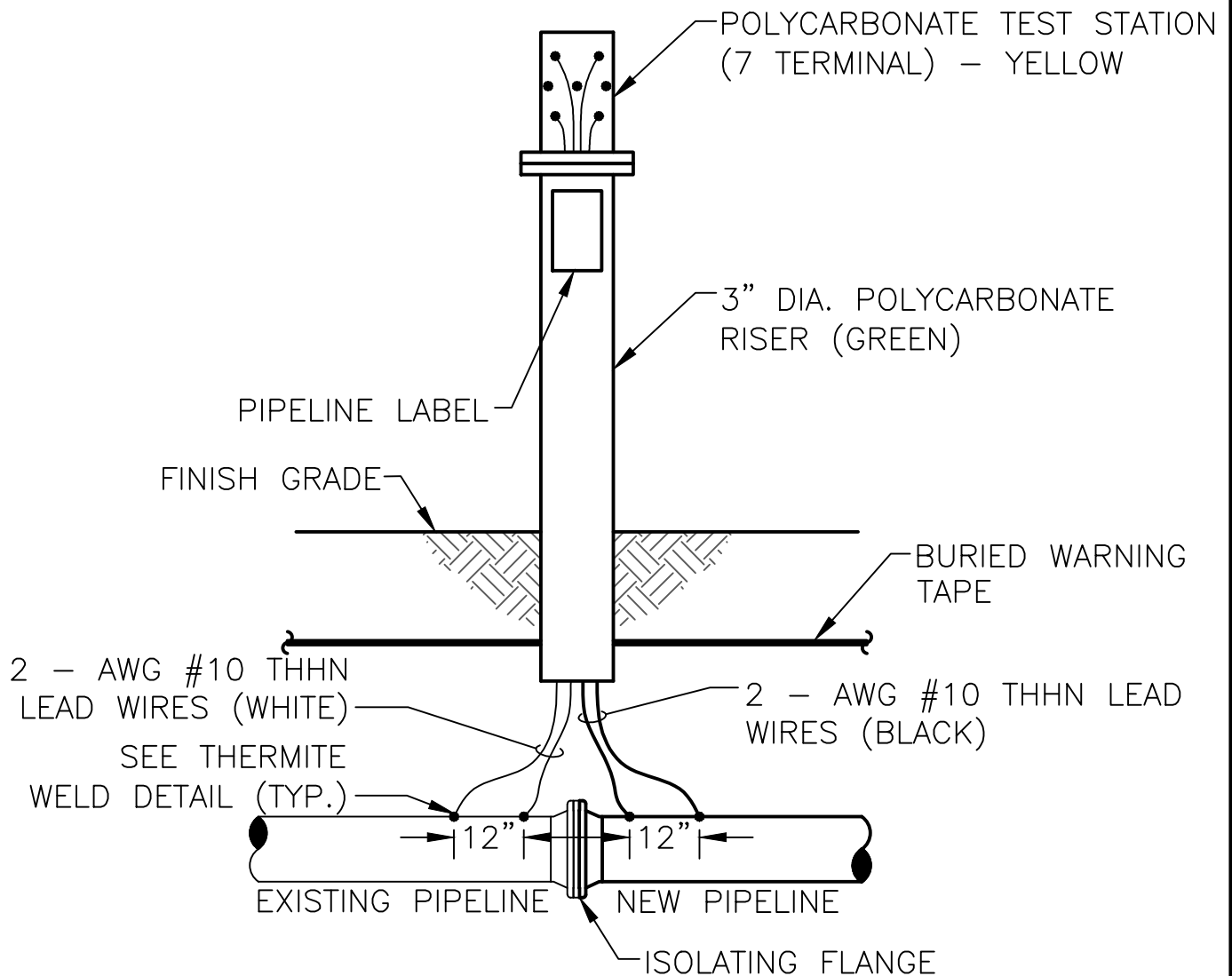

NOTES:

1. WHEN TEST STATION IS OUT OF THE ROAD, USE A GREEN RISER PROTECTED BY BOLLARDS.

NOT TO SCALE



STANDARD DESIGN DETAIL

ISOLATION FLANGE TEST STATION (WITH RISER)

DRAWING NO.
506

SHEET
1 OF 1

DATE
7/2026

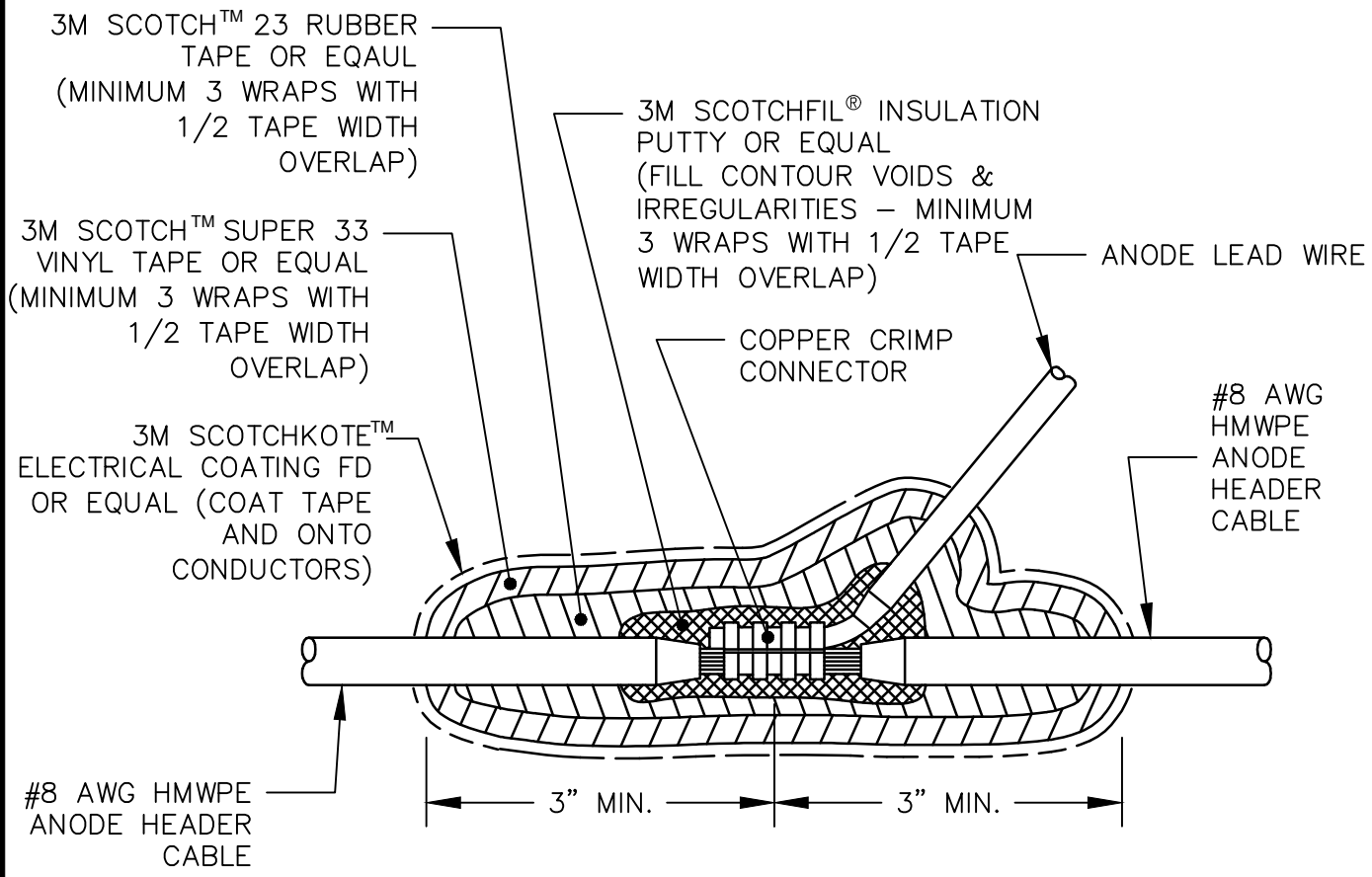

NOTE:
 1. ALL SURFACES TO BE CLEAN, DRY AND FREE OF OIL, GREASE AND OTHER DEBRIS PRIOR TO INSTALLING SPLICE COATING MATERIALS.

NOT TO SCALE

	STANDARD DESIGN DETAIL	DRAWING NO. 507
	ANODE HEADER CABLE SPLICE – WYE TYPE	SHEET 1 OF 1
		DATE 7/2026

STEP 1. WEAR PROPER CLOTHING, SAFETY GLASSES AND GLOVES WHEN THERMITE WELDING. AVOID BREATHING CONCENTRATIONS OF SMOKE, AS IT MAY BE HAZARDOUS TO YOUR HEALTH. REMOVE OR PROTECT FIRE HAZARDS IN THE WELDING AREA. FAILURE TO ABIDE BY THESE SAFETY PROCEDURES MAY RESULT IN HAZARDOUS SITUATIONS TO THE INDIVIDUAL AND BYSTANDERS.

STEP 2. SECURE TEST WIRES TO PIPE PRIOR TO THERMITE WELDING.

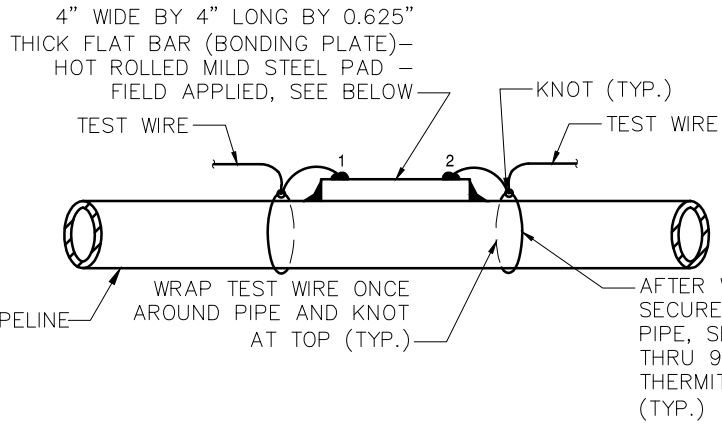

STEP 3. REMOVE BONDING PLATE COATING AREA, 4"x4".

STEP 4. REMOVE BONDING PLATE COATING AREA, 3"x3" & GRIND STRUCTURE CONNECTION AREA TO BARE SHINY METAL AND CLEAN. SURFACE TO BE WELDED MUST BE BRIGHT CLEAN WITH FILE OR WIRE BRUSH AND DRY. UNDER SOME CONDITIONS OF TEMPERATURE AND HUMIDITY, THE SURFACE TO BE WELDED WILL SWEAT CAUSING POROUS WELDS. THIS CAN BE ELIMINATED WITH A HAND TORCH PRIOR TO WELDING.

STEP 5. STRIP INSULATION FROM WIRE. EXPOSED CONDUCTORS MUST BE BRIGHT, CLEAN AND DRY. WET CABLES CAN BE DRIED OUT USING A HAND TORCH.

STEP 6. CHECK MOLD TAG FOR MATERIAL TO BE WELDED AND PROPER CARTRIDGE SIZE TO BE USED. MOLD CAN BE DRIED USING A HAND TORCH. PLACE END OF CABLE TO THE CENTER LINE OF THE TAP HOLE. INSERT STEEL DISK BEING SURE IT IS CENTERED OVER THE TAP HOLE. POUR PROPER METAL WELDING POWDER INTO THE CRUCIBLE. CLOSE THE MOLD LID. PLACE SMALL AMOUNT OF STARTING POWDER IN THE IGNITION POCKET. HOLD MOLD FIRMLY BY HANDLE WITH OPENING AWAY FROM INDIVIDUAL AND IGNITE WITH FLINT GUN (NOTE: INDIVIDUAL MUST NOT PLACE EXPOSED BODY PART DIRECTLY OVER LID OR IN FRONT OF LID OPENING TO AVOID INJURY). WAIT 15 SECONDS BEFORE OPENING THE MOLD TO ALLOW WELD METAL TO COOL. FAILURE TO FOLLOW WELDING PROCEDURES MAY RESULT IN IMPROPER WELDS AND DAMAGE TO THE MATERIAL BEING WELDED.

STEP 7. AS SOON AS THE WELD HAS COOLED, ALL WELD SLAG SHALL BE REMOVED AND THE WELDMENT TESTED FOR STRENGTH BY STRIKING A SHARP BLOW WITH A TWO POUND BALL PEEN HAMMER WHILE PULLING FIRMLY ON THE WIRE. ALL UNSOUND WELDS SHALL BE REWELDED AND RETESTED AT THE CONTRACTOR'S EXPENSE. MOLD AND MOLD COMVERS SHALL BE THOROUGHLY CLEANED AFTER COMPLETION OF EACH WELD TO ASSURE THAT NO SLAG WILL PENETRATE INTO THE NEXT WELD.

STEP 8. IF WELD BECAME LOOSE DURING PEENING, A NEW WELD MUST BE MADE NOT LESS THAN 6" FROM THE FAILED WELD.

STEP 9. APPLY ROYSTON HANDY CAP IP™ APPLICATION OVER COMPLETED WELD CONNECTION, SEE DETAIL 508-B.

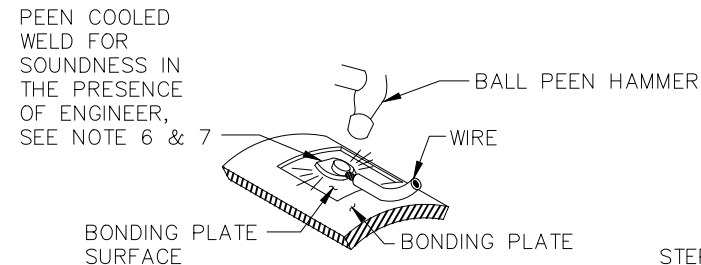
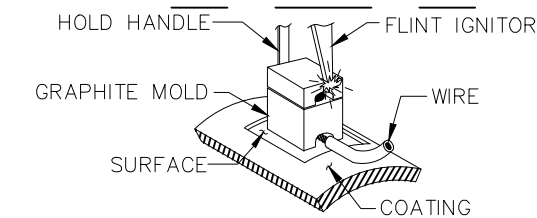
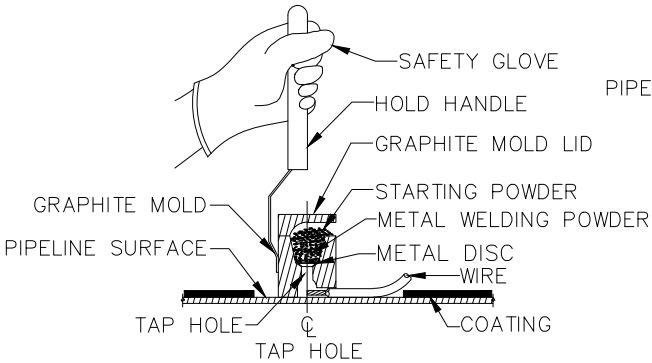

NOTES:

1. PIPELINES WITH INTERIOR PROTECTIVE COATING SYSTEMS REQUIRE BONDING PLATES FOR THERMITE WELDS. SEE STANDARD DETAIL 510.
2. WHEN BONDING PLATES ARE NOT PRESENT (TIE-IN LOCATIONS, FIELD CUTS, ETC.), PIN BRAZING METHODS MAY BE UTILIZED, SEE STANDARD DETAIL 511.
3. INTERIOR COATING SYSTEM DAMAGED CAUSED BY THERMITE WELDING OR PIN BRAZING METHODS SHALL BE REPAIRED IN ACCORDANCE WITH THE COATING MANUFACTURES RECOMMENDATIONS.

TYPICAL THERMITE WELD PROCEDURES ON BONDING PLATE

NOT TO SCALE



STANDARD DESIGN DETAIL

TYPICAL THERMITE WELD PROCEDURES ON BONDING PLATE

DRAWING NO.
508A

SHEET
1 OF 2

DATE
7/2026

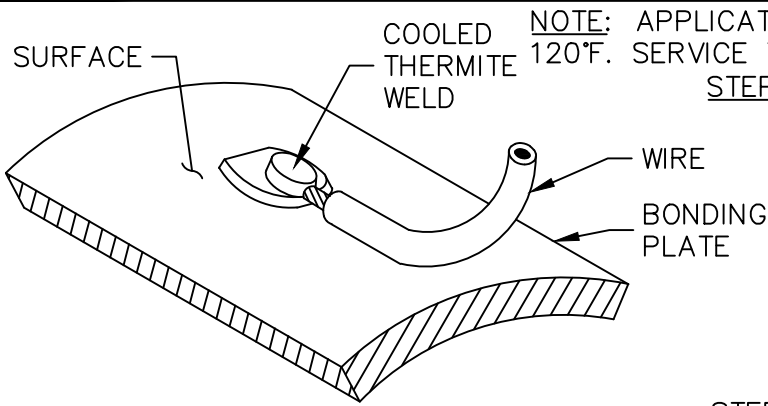

NOTE: APPLICATION TEMPERATURE RANGE IS -20°F TO 120°F. SERVICE TEMPERATURE RANGE IS -40°F TO 150°F.

STEP 1. CLEAN ALL MUD, DIRT, GREASE, OIL AND OTHER CONTAMINANTS FROM THE METAL PIPE SURFACE AND MILL COATING (IF APPLICABLE) WHICH IS TO BE COVERED. THE HANDY CAP IP INCORPORATES AN INTERGRATED PRIMER IN ITS TAPECOAT GRAY ADHESIVE AND DOES NOT REQUIRE THE USE OF A LIQUID PRIMER TO APPLICATION.

STEP 2. REMOVE THE RELEASE PAPER FROM THE BOTTOM OF THE HANDY CAP IP. POSITION AND PLACE THE HANDY CAP IP ON THE WELDED AREA WITH THE TUNNEL OVER THE LEAD WIRE.

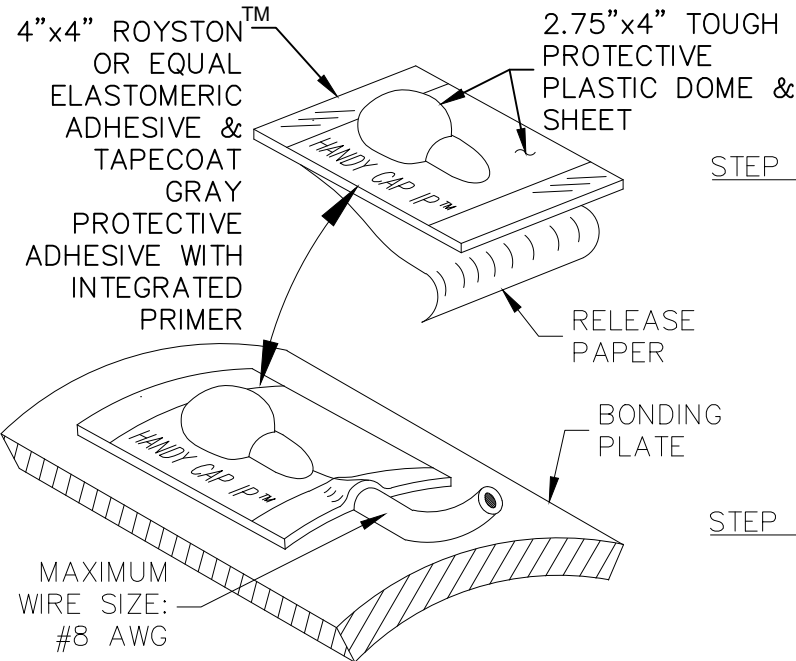

STEP 3. PUSH THE DOME OF THE CAP FIRMLY INTO THE WELD AREA. LIFT THE LEAD WIRE AWAY FROM THE PIPE AND SQUEEZE THE ADHESIVE COMPOUND COMPLETELY AROUND AND UNDERNEATH THE WIRE. PUSH THE LEAD WIRE BACK DOWN ON THE PIPE AND PRESS THE ELASTOMERIC COMPOUND INTO FIRM CONTACT WITH THE PIPE AND PRESS OVER THE ENTIRE AREA.

STEP 4. NO FURTHER PROTECTION IS REQUIRED WHEN THE HANDY CAP IP COVERS THE ENTIRE EXPOSED METAL AREA. UNCOVERED AREAS SHOULD BE PROTECTED WITH PRIMERLESS TAPECOAT OR ROYSTON OR EQUAL TAPES.

APPLICATION TO UNCOATED PIPE OR REINFORCING COUPON

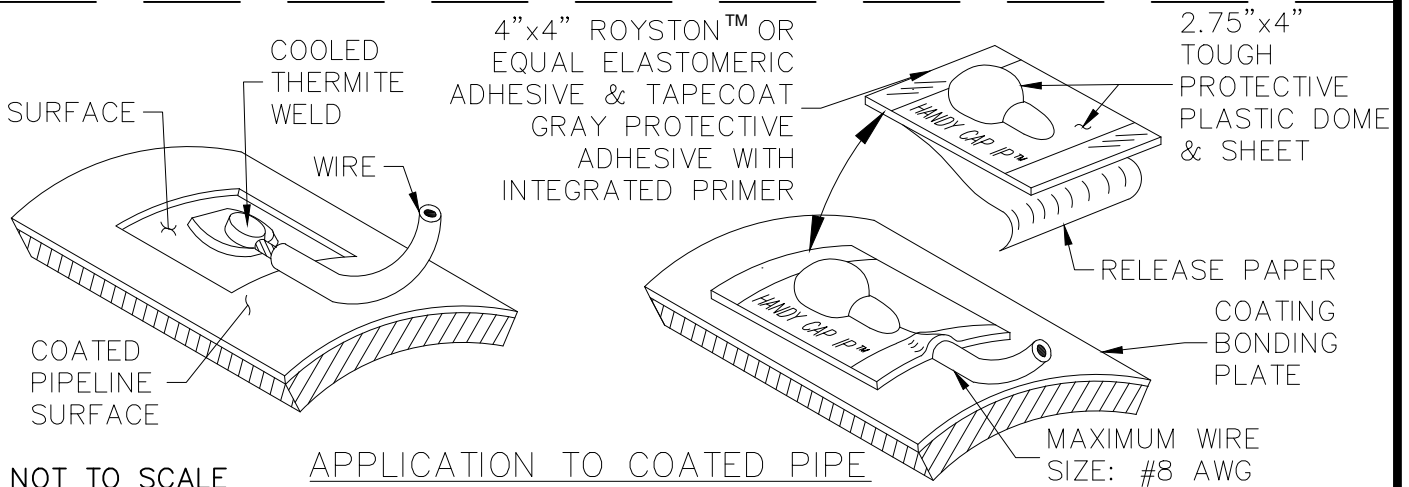

NOT TO SCALE

APPLICATION TO COATED PIPE

	STANDARD DESIGN DETAIL	DRAWING NO. 508B
	TYPICAL ROYSTON HANDY CAP IP™ INSTALLATION	SHEET 2 OF 2
		DATE 7/2026

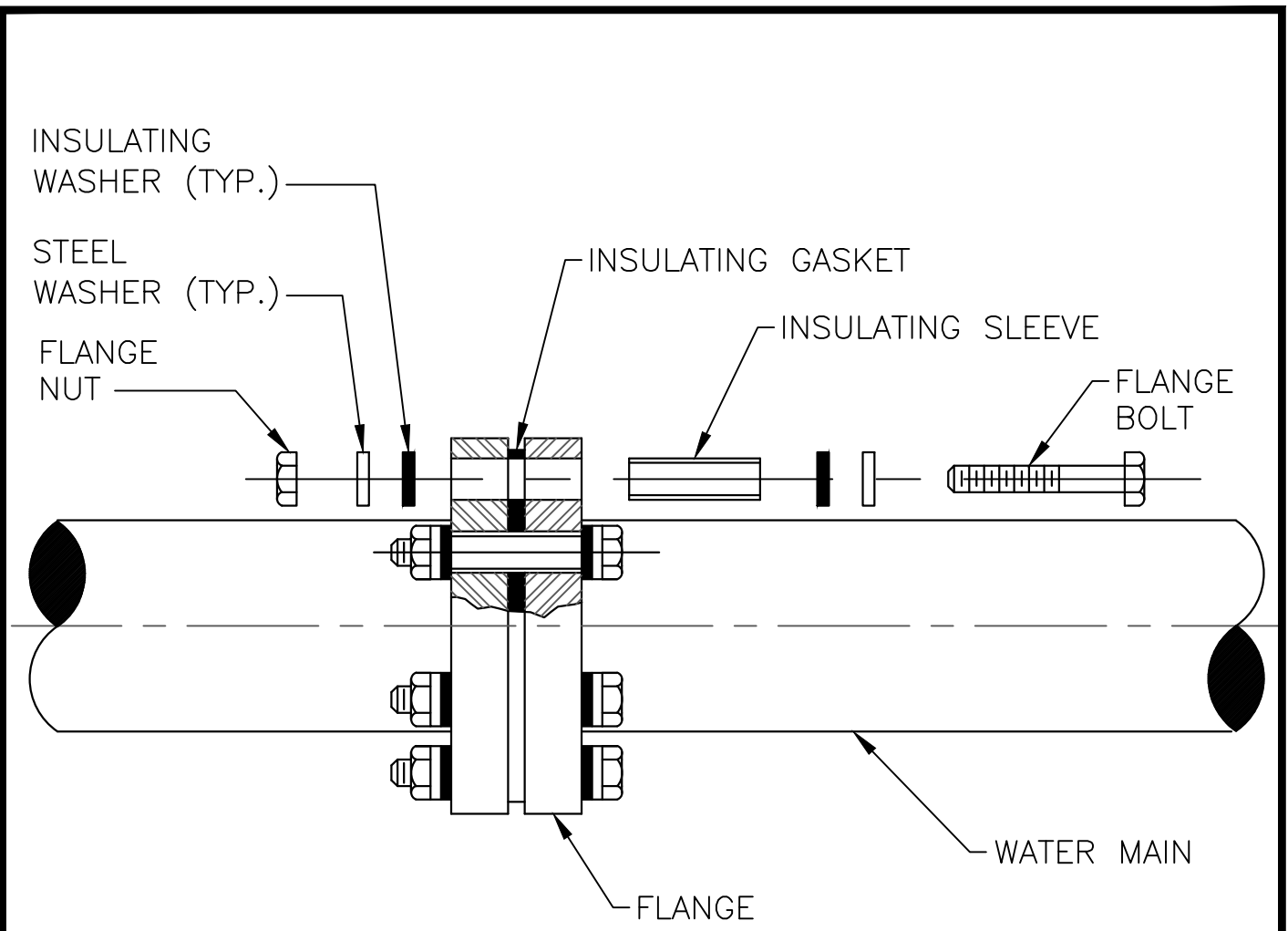

NOTES:

1. AFTER ASSEMBLY, TEST TO VERIFY THAT ISOLATION IS EFFECTIVE. IF ISOLATION IS NOT EFFECTIVE, REPAIR AS NECESSARY AND RETEST. THIS PROCESS SHALL CONTINUE UNTIL ISOLATION IS VERIFIED AS EFFECTIVE.
2. AFTER VERIFYING EFFECTIVE ISOLATION, COAT THE ENTIRE FLANGE AND ALL EXPOSED METAL INCLUDING BOLTS, NUTS, AND WASHERS WITH FOUR COMPONENTS OF DENSO OR TRENTON WAX TAPE COATING SYSTEM. COATING SYSTEM SHALL EXTEND A MINIMUM OF 12 INCHES ON EITHER SIDE OF FLANGE.
3. ALL INSULATING FLANGES TO BE PROVIDED WITH TEST STATIONS.

NOT TO SCALE



STANDARD DESIGN DETAIL

ISOLATING FLANGE KIT

DRAWING NO.
509

SHEET
1 OF 1

DATE
7/2026

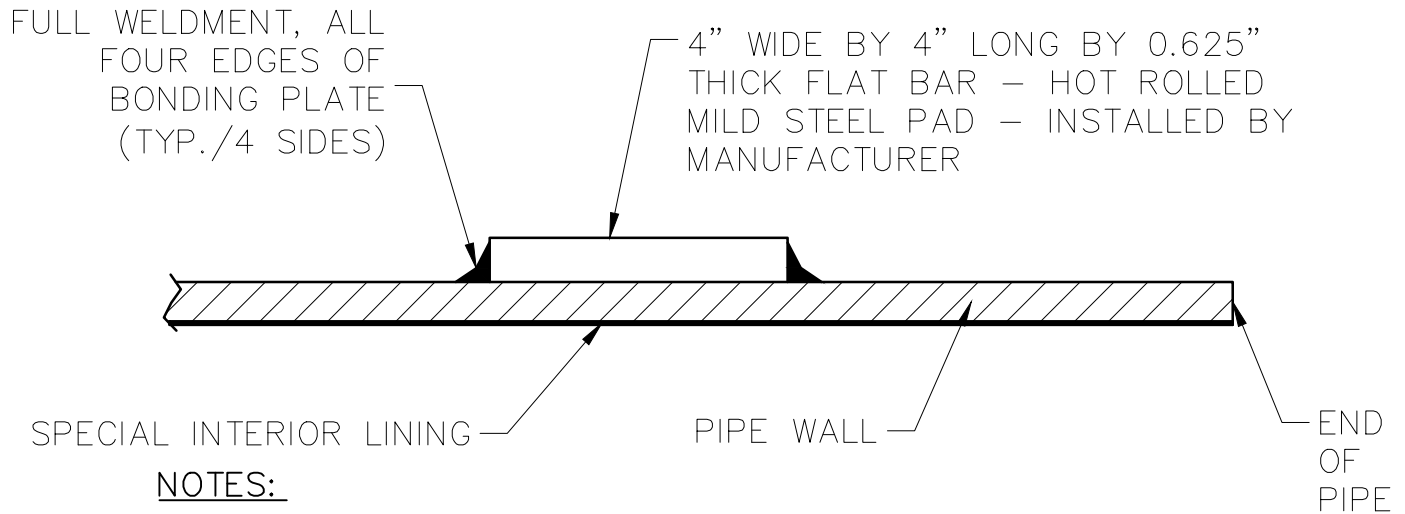
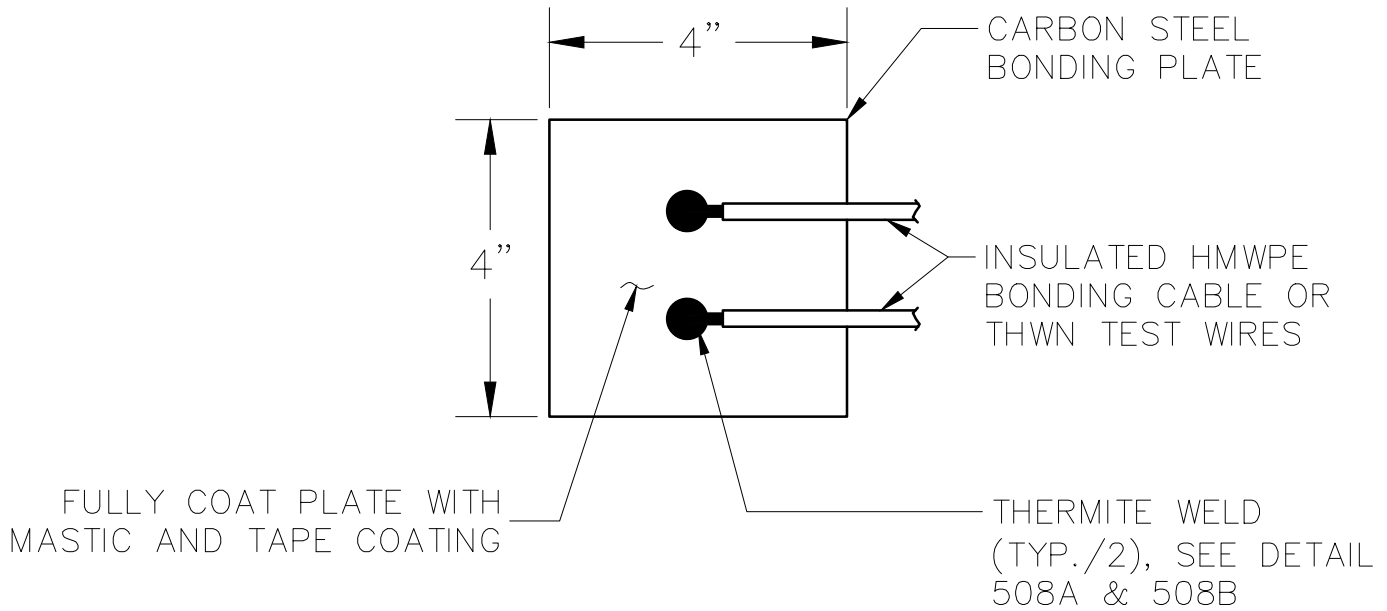

NOTES:

1. PROVIDE BONDING PLATES FOR PIPELINES WITH INTERIOR PROTECTIVE COATING SYSTEMS.
2. BONDING PLATES TO BE INSTALLED BY THE MANUFACTURER PRIOR TO INTERIOR PROTECTIVE COATING SYSTEM APPLICATION.
3. COORDINATE WITH PIPE MANUFACTURER TO POSITION BONDING PLATES ON THE SPIGOT END OF THE PIPE WITH RESPECT TO PIPE DIAMETER AND CORRESPONDING SOCKET DEPTH.

NOT TO SCALE



STANDARD DESIGN DETAIL

TYPICAL BONDING PLATE

DRAWING NO.

510

SHEET

1 OF 1

DATE

7/2026

STEP 1.
REMOVE COATING & CLEAN PIPE

- A. BUFF WIRE-TO-PIPE CONNECTION AREA (2"x3") TO BARE SHINY METAL WITH 4" ANGLE GRINDER WITH 80 GRIT FLAP WHEEL ATTACHMENT AND CLEAN.
- B. BUFF THE GROUND MAGNET CONNECTION AREA TO BARE SHINY METAL WITH 4" ANGLE GRINDER WITH 80 GRIT FLAP WHEEL ATTACHMENT AND CLEAN.



STEP 2.
LOAD THE GUN WITH A BRAZING PIN AND FERRULE

- A. INSERT THE BRAZING PIN
- B. THEN INSERT THE FERRULE
- C. THEN INSERT THE CABLE LUG

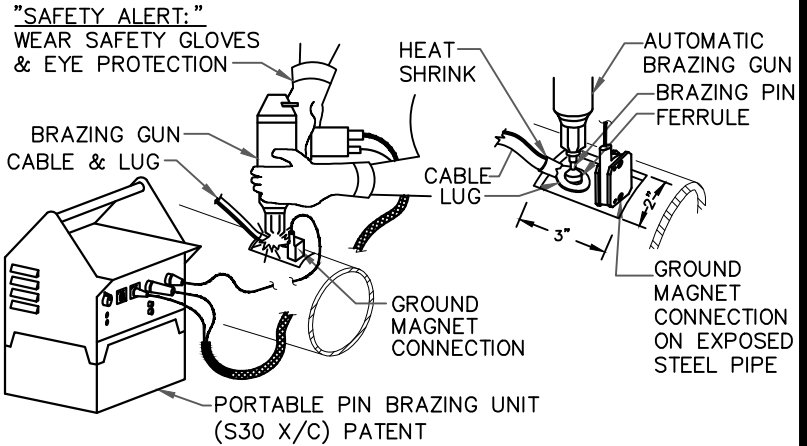
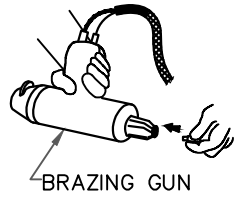

STEP 3.
THE CABLE AND LUG ARE BRAZED TO THE PIPE

- A. PLACE GROUND MAGNET CONNECTION ON EXPOSED STEEL PIPE SURFACE AS SHOWN.
- B. PLACE THE CABLE LUG AND THE AUTOMATIC GUN ON THE EXPOSED STEEL PIPE SURFACE AS SHOWN.
- C. PULL THE TRIGGER. THE PROCESS STARTS AND A SILVER CAPSULE IS OPENED AND A FLUX IS CLEANING THE SURFACE.
- D. THE SILVER IS MELTED AROUND THE WIRE IN THE CABLE ITSELF AND THE WORKING MATERIAL.

NOTES (READ FIRST BEFORE BRAZING)

- 1. GENERAL PROCEDURES IN THIS DETAIL ARE SHOWN FOR THE CONVENIENCE OF THE CONTRACTOR ONLY. ACTUAL INSTALLATION INSTRUCTIONS PROVIDED BY THE MANUFACTURER SHALL BE FOLLOWED.
- 2. "SAFETY ALERT:" PIPELINES AND APPURTENANCES CONSTRUCTED IN THE VICINITY OF OVERHEAD POWER LINES CAN EXPERIENCE UNSAFE ELECTRICAL VOLTAGES AND POTENTIALLY LETHAL SHOCK HAZARDS WHILE THIS EQUIPMENT IS BEING HANDLED ABOVEGROUND AND UPON PLACEMENT IN THE PIPE TRENCH. CONTRACTOR IS RESPONSIBLE FOR ALL PERSONNEL AND EQUIPMENT SAFETY DURING THE COURSE OF CONSTRUCTION INCLUDING BUT NOT LIMITED TO AWARENESS TRAINING, ALL SAFETY PRECAUTIONS AND INTERIM ELECTRICAL GROUNDING.
- 3. FOR GALVANIZED PIPE STRAPS, REMOVE ZINC COATING DOWN TO WHITE METAL PRIOR TO PIN BRAZING.

STEP 4.
KNOCK OFF THE CONTROL SHAFT & TEST CONNECTION

AS SOON AS THE WELD HAS COOLED, ALL WELD SLAG SHALL BE REMOVED AND THE WELDMENT TESTED FOR STRENGTH BY STRIKING A SHARP BLOW WITH A TWO POUND BALL PEEN HAMMER WHILE PULLING FIRMLY ON THE WIRE. ALL UNSOUND WELDS SHALL BE REWELDED AND RETESTED AT THE CONTRACTOR'S EXPENSE. MOLD AND MOLD COVERS SHALL BE THOROUGHLY CLEANED AFTER COMPLETION OF EACH WELD TO ASSURE THAT NO SLAG WILL PENETRATE INTO THE NEXT WELD.

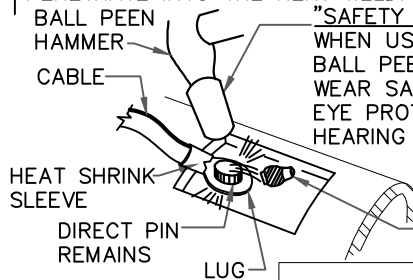

"SAFETY ALERT:" WHEN USING THE BALL PEEN HAMMER, WEAR SAFETY GLOVES, EYE PROTECTION & HEARING PROTECTION

STEP 5.
PIN BRAZED CONNECTION COATING

- A. METAL SURFACE TO BE DRY AND FREE OF ALL FOREIGN MATERIAL.
- B. REPAIR COATING AT WIRE-TO-PIPE CONNECTIONS IN ACCORDANCE WITH CLIENT COATING MANUAL.

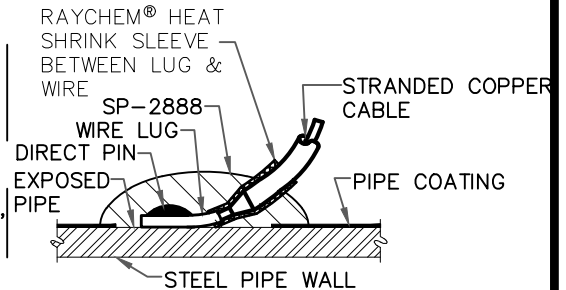

CONTROL SHAFT BREAKS OFF

WIRE SIZE	RAYCHEM HEAT SHRINK	TERMINAL SLEEVE	SAFETRACK UNIT			BAC (EASY BOND) UNIT			
			CABLE LUG	BRAZING PIN	FERRULE	STINGER CONNECTION	CABLE LUG	BRAZING PIN	FERRULE
#12 AWG	WCSM-13/4-150-S	6701	6056	10051	2003	278-100-8010	N/A	278-190-3250	270-065-7230
#10 AWG	WCSM-13/4-150-S	6702	6056	10051	2003	278-100-8040	N/A	278-190-3250	270-065-7230
#8 AWG	WCSM-13/4-150-S	N/A	6056	10051	2003	N/A	278-100-9830	278-190-3250	270-065-7230
#6 AWG	WCSM-20/6-150-S	N/A	6057	10051	2003	N/A	278-100-9830	278-190-3250	270-065-7230
#4 AWG	WCSM-20/6-150-S	N/A	6080	10301	2003	N/A	278-100-9000	278-190-3250	270-065-7230
#2 AWG	WCSM-20/6-150-S	N/A	6081	10301	2003	N/A	270-088-7800	270-083-3520	270-065-7230
#1 AWG	WCSM-33/8-150-S	N/A	6079	10301	2003	N/A	278-100-7810	270-083-3520	270-065-7230

NOT TO SCALE

STANDARD DESIGN DETAIL



COPPER WIRE TO PIPE PIN BRAZING PROCEDURES

DRAWING NO.
511
SHEET
1 OF 1
DATE
7/2026

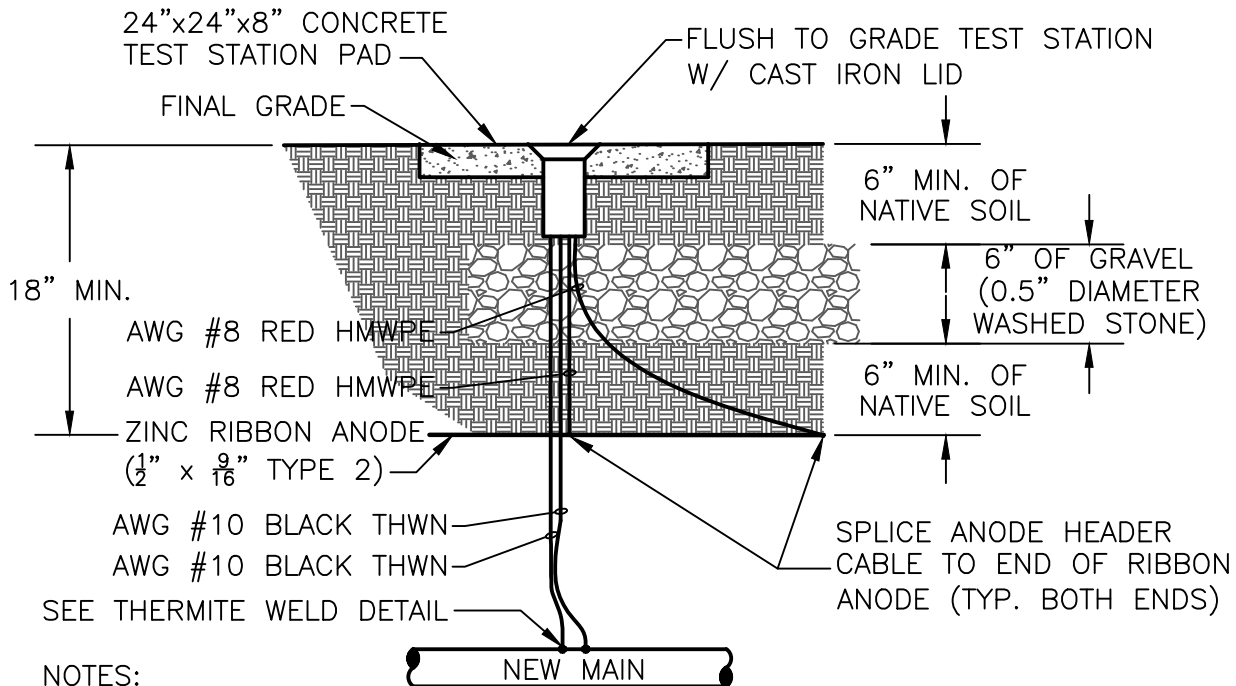
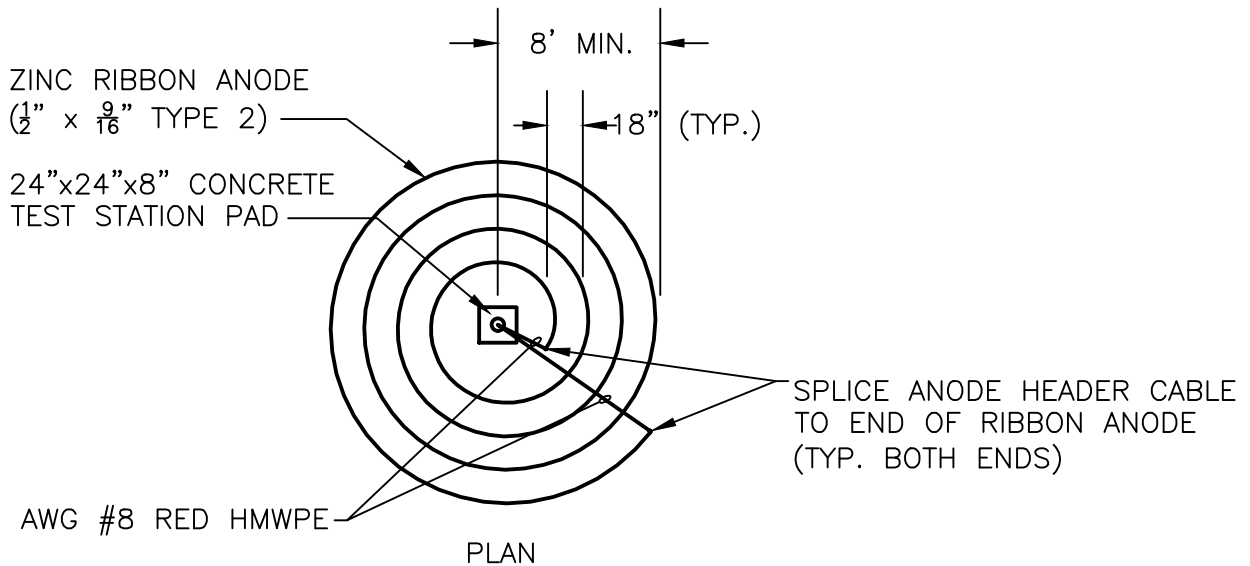

NOTES:

1. TEST STATIONS LOCATED ALONG PAVED ROADWAYS SHALL GENERALLY BE LOCATED 3 FEET OUTSIDE OF THE EDGE OF PAVEMENT IN A NON-PAVED AREA. ROUTE ALL TEST WIRES AT A MINIMUM DEPTH OF 24 INCHES TO THE FINAL TEST STATION LOCATION. TEST STATION LOCATIONS SHALL BE FIELD ADJUSTED.
2. ROUTE WIRES IN 1 INCH PVC CONDUIT TO TEST BOX. INSTALL CABLE WARNING TAPE 18 INCHES ABOVE PVC CONDUIT.
3. MAINTAIN SUFFICIENT SLACK IN THE TEST WIRES SO THAT THE WIRES CAN EXTEND A MINIMUM OF 18 INCHES FROM THE TEST BOX.
4. INSTALL 0.1 OHM SHUNT (YELLOW) BETWEEN TERMINALS #1 AND #4.
5. AT FIRE HYDRANTS, VAULTS, AND OTHER APPURTENANCES, ZINC RIBBON ANODE SHALL BE COILED AROUND FIRE HYDRANT, VAULT, OR APPURTENANCE.

NOT TO SCALE



STANDARD DESIGN DETAIL

DUCTILE IRON PIPE GALVANIC SYSTEM
AC GROUND MAT

DRAWING NO.
521

SHEET
1 OF 1

DATE
7/2026

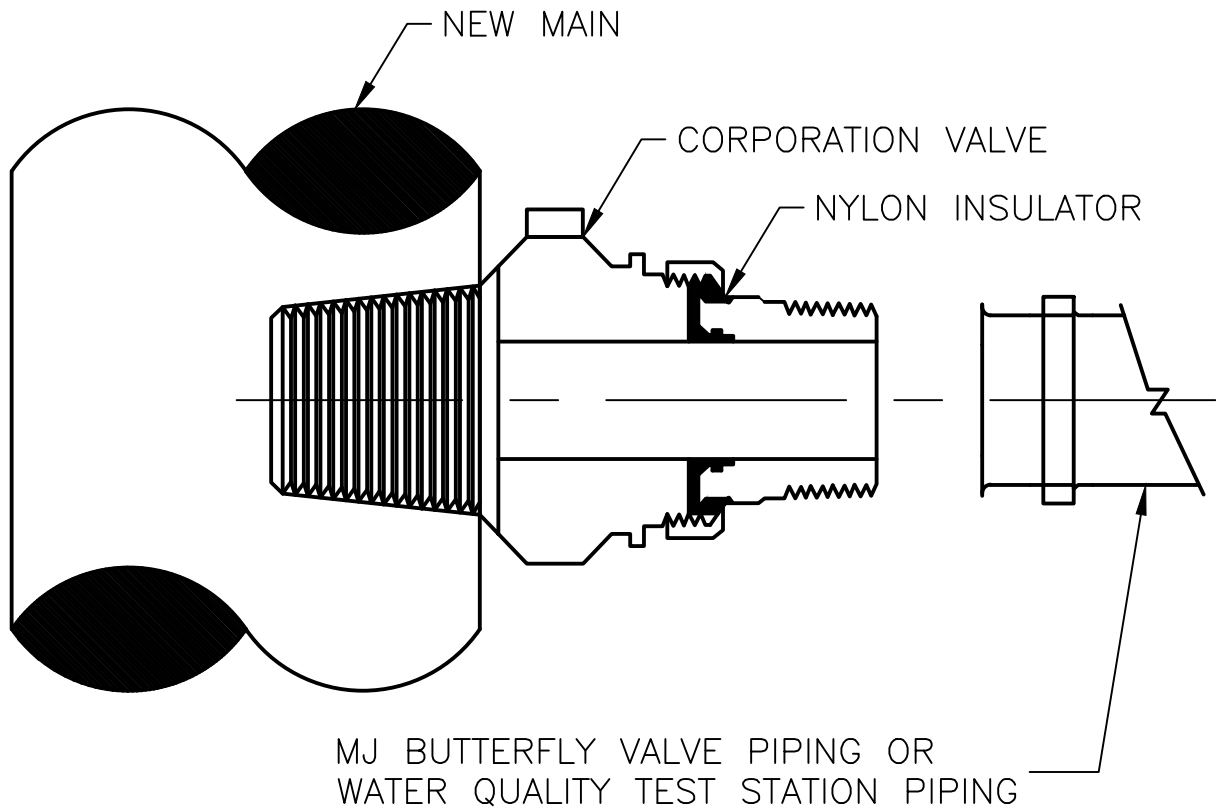

NOTES:

1. AFTER ASSEMBLY, TEST TO VERIFY THAT ISOLATION IS EFFECTIVE. IF ISOLATION IS NOT EFFECTIVE, REPAIR AS NECESSARY AND RETEST. THIS PROCESS SHALL CONTINUE UNTIL ISOLATION IS VERIFIED AS EFFECTIVE.
2. AFTER VERIFYING EFFECTIVE ISOLATION, COAT THE ENTIRE CORPORATION AND ALL EXPOSED METAL WITH FOUR COMPONENTS OF DENSO OR TRENTON WAX TAPE COATING SYSTEM. COATING SYSTEM SHALL EXTEND A MINIMUM ON EITHER SIDE OF CORPORATION.

NOT TO SCALE



STANDARD DESIGN DETAIL
 DUCTILE IRON PIPE GALVANIC SYSTEM
 INSULATING CORPORATION

DRAWING NO. 522
SHEET 1 OF 1
DATE 7/2026

BOND WIRE (TYP.), SEE NOTE #2 — SEE THERMITE WELD DETAIL (TYP.)

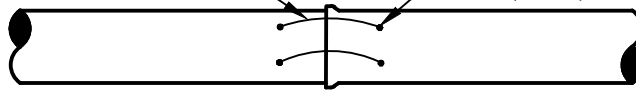

TYPICAL MAIN JOINT BOND

BOND WIRE (TYP.), SEE NOTE #2 — SEE THERMITE WELD DETAIL (TYP.)

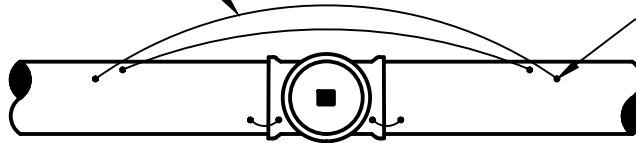

VALVE

BOND WIRE (TYP.), SEE NOTE #2 — SEE THERMITE WELD DETAIL (TYP.)



MECHANICAL COUPLING

BOND WIRE (TYP.), SEE NOTE #2 — SEE THERMITE WELD DETAIL (TYP.)

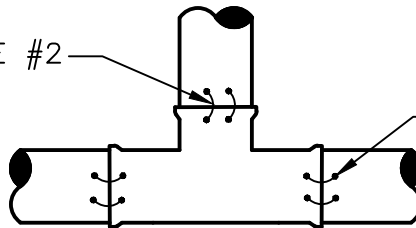

BOND WIRE (TYP.), SEE NOTE #2 — SEE THERMITE WELD DETAIL (TYP.)

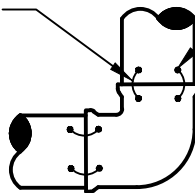

BEND, REDUCER, SOLID SLEEVE

NOTES:

1. THERMITE WELD BONDING WIRES TO TOP OF MAIN FITTINGS.
2. WIRE SIZE FOR BONDING JOINTS SHALL BE AS FOLLOWS:

MAIN SIZE
LARGER THAN 36 INCHES
16 INCHES TO 36 INCHES
12 INCHES AND SMALLER

WIRE SIZE
AWG #2 HMWPE
AWG #4 HMWPE
AWG #6 HMWPE

NOT TO SCALE



STANDARD DESIGN DETAIL

DUCTILE IRON PIPE GALVANIC SYSTEM
MAIN BONDING

DRAWING NO. 523
SHEET 1 OF 1
DATE 7/2026