

**NOTES:**

1. FL X PE NIPPLE WITH MEGA-LUG.
2. PE X PE NIPPLES WITH MEGA-LUGS. THE USE OF FOSTER ADAPTERS WILL BE CONSIDERED ON A CASE-BY-CASE BASIS BY HRSD.
3. JURISDICTION VALVE.
  - a. JURISDICTION VALVE TO BE SAME SIZE AS EXISTING HRSD VALVE.
  - b. ECCENTRIC REDUCERS TO BE INSTALLED AS NEEDED AFTER JURISDICTION VALVE.
  - c. HRSD PIPELINES THAT HAVE CORROSION PROTECTION IN PLACE WILL REQUIRE AN ISOLATION COUPLING. CONTACT THE HRSD ENGINEER FOR DETAILS.

NOT TO SCALE

	STANDARD DESIGN DETAIL	DRAWING NO. 300
	CONNECTION TO EXISTING HRSD VALVE NO POTENTIAL FOR ADDITIONAL DEVELOPMENT	SHEET 1 OF 1
		DATE 9/2018

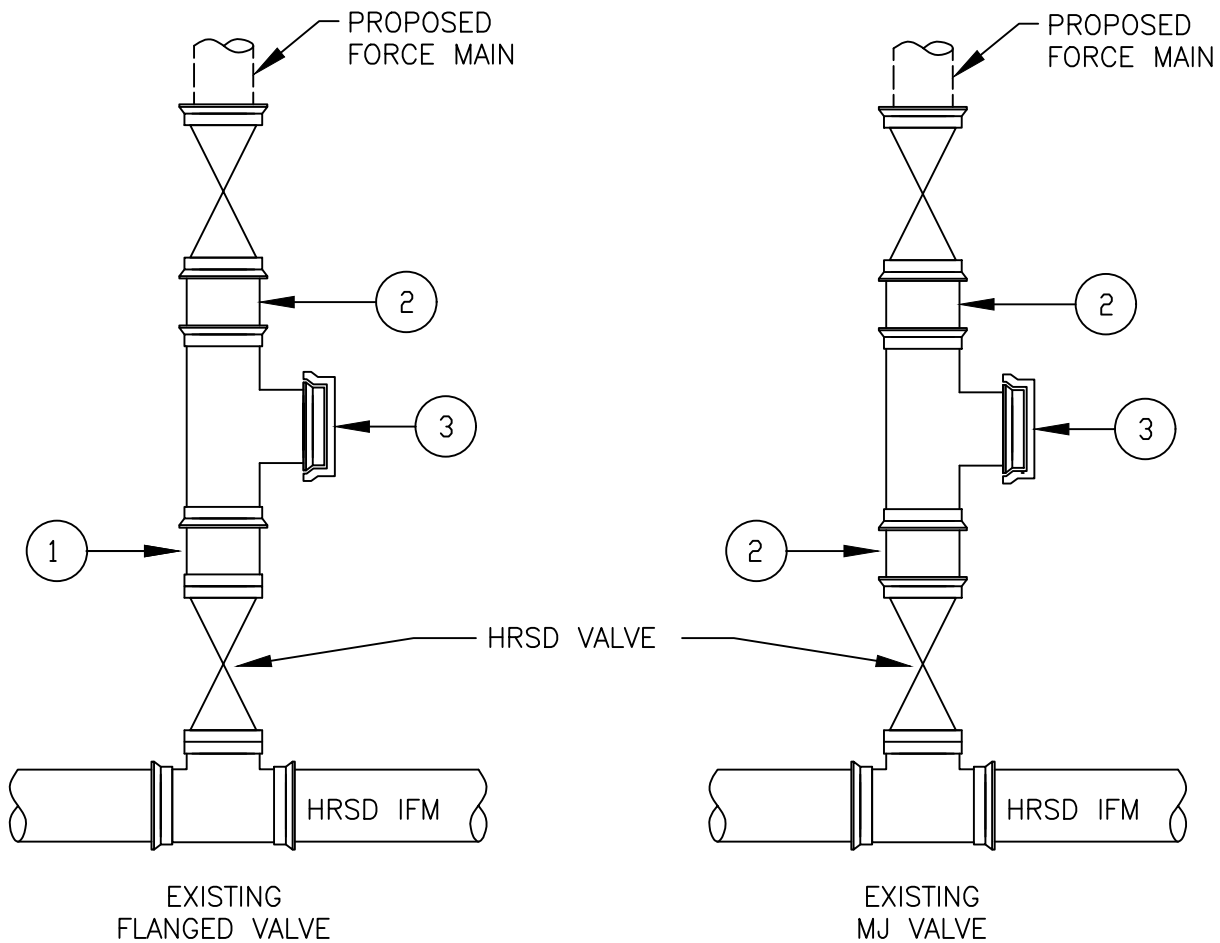

NOTES:

1. FL X PE NIPPLE WITH MEGA-LUG.
2. PE X PE NIPPLES WITH MEGA-LUGS. THE USE OF FOSTER ADAPTERS WILL BE CONSIDERED ON A CASE-BY-CASE BASIS BY HRSD.
3. MJ CAP/PLUG.
  - a. JURISDICTION TO OWN TEE AND VALVE UPSTREAM OF HRSD VALVE.
  - b. TEE AND JURISDICTION VALVE TO BE SAME SIZE AS EXISTING HRSD VALVE.
  - c. ECCENTRIC REDUCERS TO BE INSTALLED AS NEEDED AFTER JURISDICTION VALVE.
  - d. HRSD PIPELINES THAT HAVE CORROSION PROTECTION IN PLACE WILL REQUIRE AN ISOLATION COUPLING. CONTACT THE HRSD ENGINEER FOR DETAILS.

NOT TO SCALE



STANDARD DESIGN DETAIL

CONNECTION TO EXISTING HRSD VALVE  
ADDITIONAL DEVELOPMENT IS POSSIBLE

DRAWING NO.  
301

SHEET  
1 OF 1

DATE  
9/2018

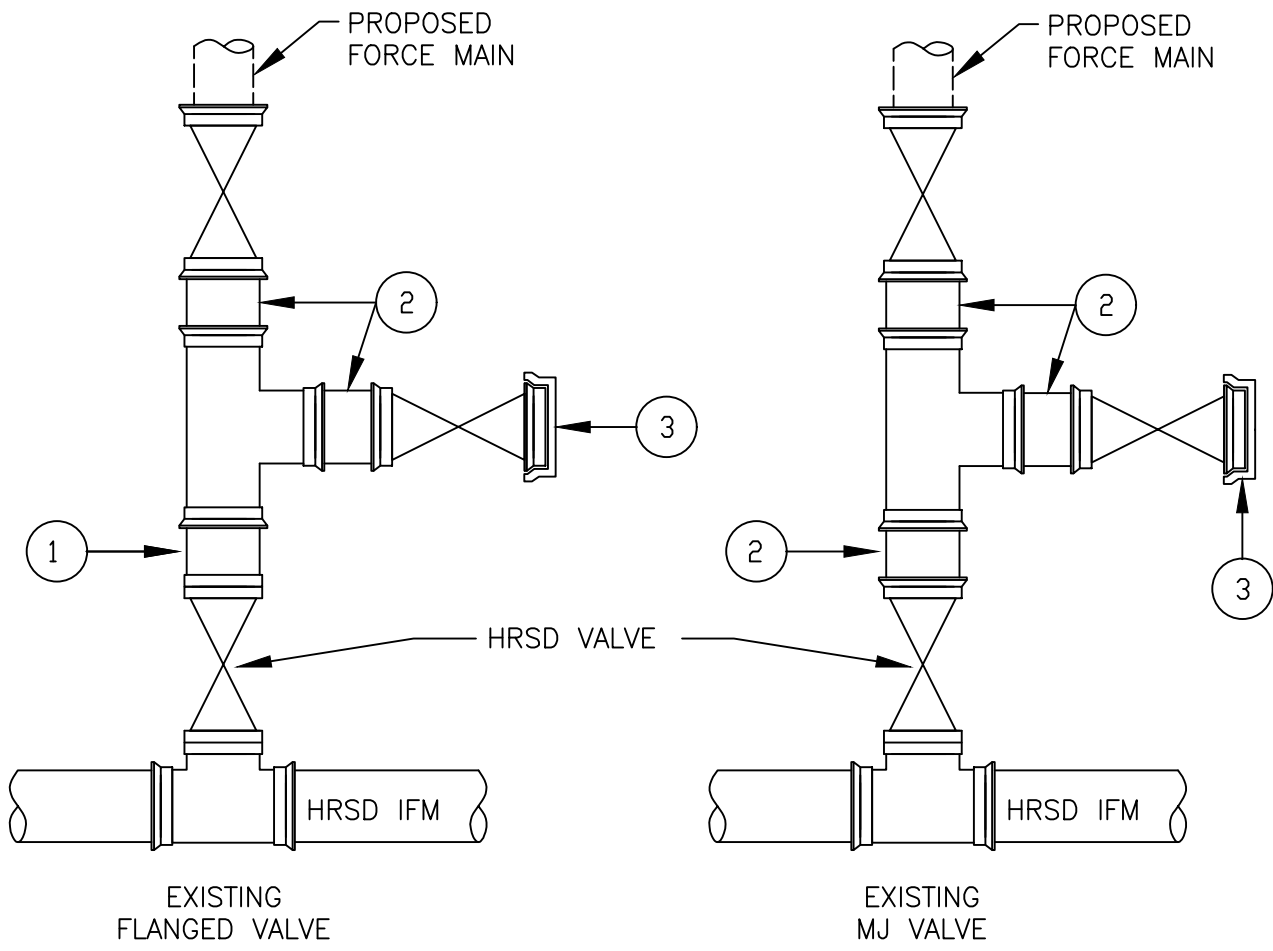

**NOTES:**

1. FL X PE NIPPLE WITH MEGA-LUG.
2. PE X PE NIPPLES WITH MEGA-LUGS. THE USE OF FOSTER ADAPTERS WILL BE CONSIDERED ON A CASE-BY-CASE BASIS BY HRSD.
3. MJ CAP/PLUG.
  - a. JURISDICTION TO OWN TEE AND VALVES UPSTREAM OF HRSD VALVE.
  - b. TEE AND JURISDICTION VALVES TO BE SAME SIZE AS EXISTING HRSD VALVE.
  - c. ECCENTRIC REDUCERS TO BE INSTALLED AS NEEDED AFTER JURISDICTION VALVE.
  - d. HRSD PIPELINES THAT HAVE CORROSION PROTECTION IN PLACE WILL REQUIRE AN ISOLATION COUPLING. CONTACT THE HRSD ENGINEER FOR DETAILS.

NOT TO SCALE

	STANDARD DESIGN DETAIL	DRAWING NO. 302
	CONNECTION TO EXISTING HRSD VALVE ADDITIONAL DEVELOPMENT IS IMMINENT	SHEET 1 OF 1
		DATE 9/2018

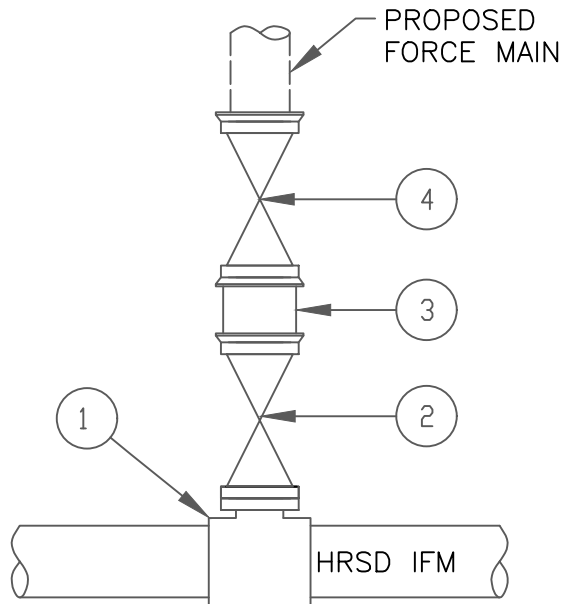

NOTES:

1. TAPPING SADDLE PER HRSD STANDARD DETAILS.
2. TAPPING VALVE (8"MIN.) (FL X MJ). TO BE OWNED BY HRSD.
3. FOSTER ADAPTER OR PE X PE NIPPLE WITH MEGA-LUGS USE OF FOSTER ADAPTORS SHALL BE APPROVED BY HRSD ON A CASE BY CASE BASIS.
4. JURISDICTION VALVE.
  - a. JURISDICTION VALVE TO BE SAME SIZE AS HRSD VALVE.
  - b. ECCENTRIC REDUCERS TO BE INSTALLED AS NEEDED AFTER JURISDICTION VALVE.
  - c. HRSD PIPELINES THAT HAVE CORROSION PROTECTION IN PLACE WILL REQUIRE AN ISOLATION COUPLING. CONTACT THE HRSD ENGINEER FOR DETAILS.

NOT TO SCALE

	STANDARD DESIGN DETAIL	DRAWING NO. 303
	NEW WET TAPS	SHEET 1 OF 1
	NO POTENTIAL FOR ADDITIONAL DEVELOPMENT	DATE 9/2018

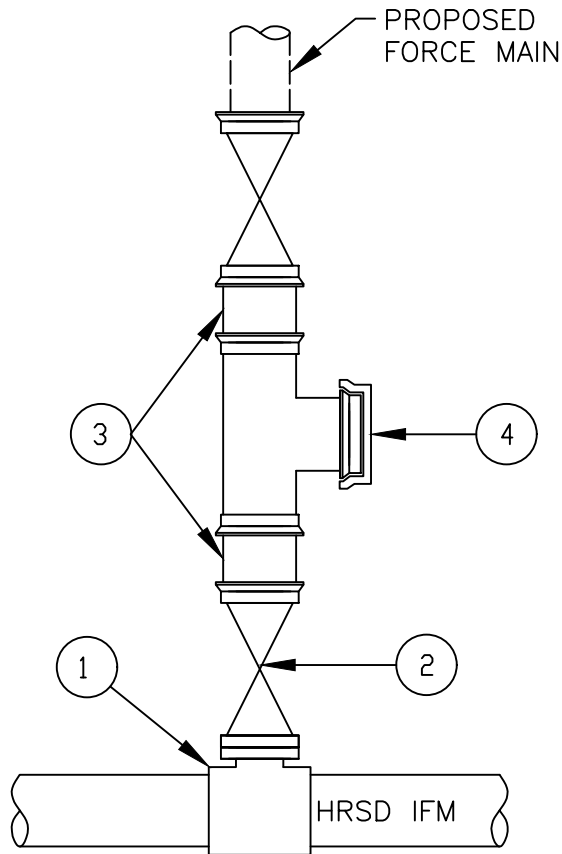

NOTES:

1. TAPPING SADDLE PER HRSD STANDARD DETAILS.
2. TAPPING VALVE (8"MIN.) (FL X MJ). TO BE OWNED BY HRSD.
3. FOSTER ADAPTERS OR PE X PE NIPPLES WITH MEGA-LUGS USE OF FOSTER ADAPTORS SHALL BE APPROVED BY HRSD ON A CASE BY CASE BASIS.
4. MJ CAP/PLUG.
  - a. JURISDICTION TO OWN TEE AND VALVE UPSTREAM OF HRSD VALVE.
  - b. TEE AND JURISDICTION VALVE TO BE SAME SIZE AS HRSD VALVE.
  - c. ECCENTRIC REDUCERS TO BE INSTALLED AS NEEDED AFTER JURISDICTION VALVE.
  - d. HRSD PIPELINES THAT HAVE CORROSION PROTECTION IN PLACE WILL REQUIRE AN ISOLATION COUPLING. CONTACT THE HRSD ENGINEER FOR DETAILS.

NOT TO SCALE



STANDARD DESIGN DETAIL

NEW WET TAPS  
ADDITIONAL DEVELOPMENT IS POSSIBLE

DRAWING NO.  
304

SHEET  
1 OF 1

DATE  
9/2018

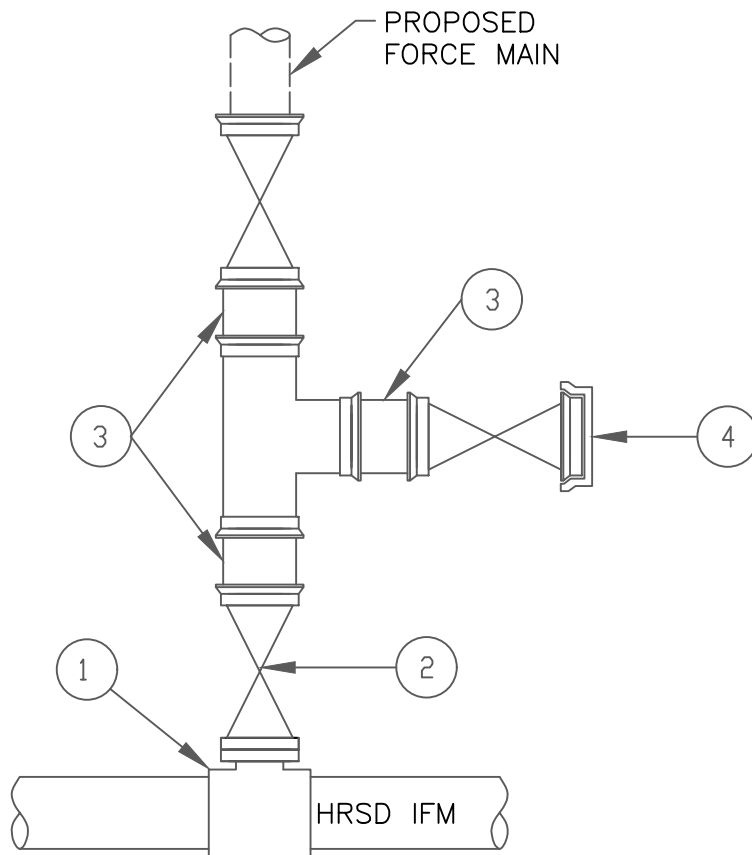

NOTES:

1. TAPPING SADDLE PER HRSD STANDARD DETAILS.
2. TAPPING VALVE (8"MIN.) (FL X MJ). TO BE OWNED BY HRSD.
3. FOSTER ADAPTERS OR PE X PE NIPPLES WITH MEGA-LUGS USE OF FOSTER ADAPTORS SHALL BE APPROVED BY HRSD ON A CASE BY CASE BASIS.
4. MJ CAP/PLUG.
  - a. JURISDICTION TO OWN TEE AND VALVES UPSTREAM OF HRSD VALVE.
  - b. TEE AND JURISDICTION VALVE TO BE SAME SIZE AS HRSD VALVE.
  - c. ECCENTRIC REDUCERS TO BE INSTALLED AS NEEDED AFTER JURISDICTION VALVE.
  - d. HRSD PIPELINES THAT HAVE CORROSION PROTECTION IN PLACE WILL REQUIRE AN ISOLATION COUPLING. CONTACT THE HRSD ENGINEER FOR DETAILS.

NOT TO SCALE



STANDARD DESIGN DETAIL

NEW WET TAPS  
ADDITIONAL DEVELOPMENT IS IMMINENT

DRAWING NO.

305

SHEET

1 OF 1

DATE

9/2018

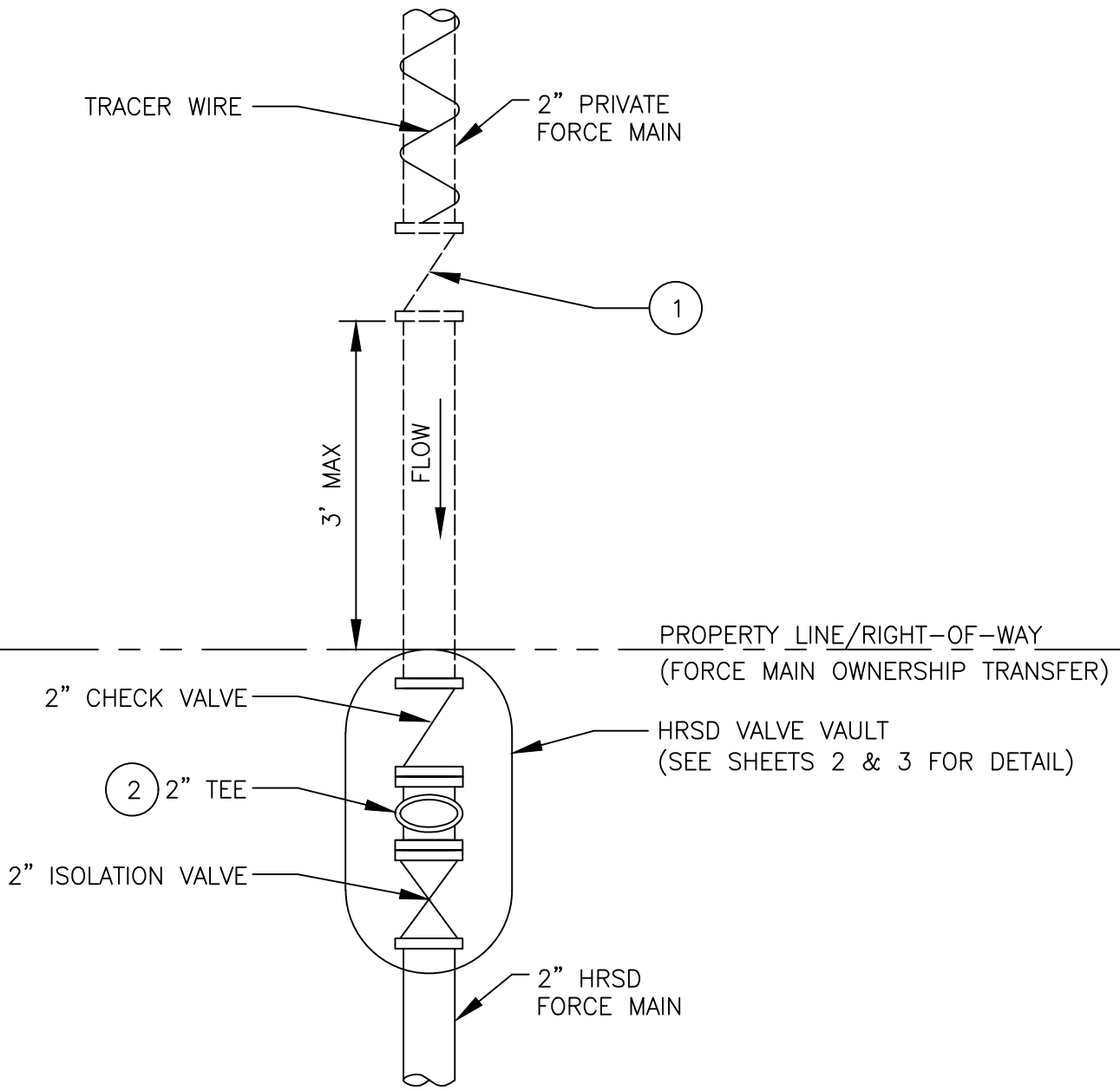

**NOTES:**

1. CHECK VALVE MUST BE INSTALLED ON PRIVATE DISCHARGE FORCE MAIN, INSIDE OF FRAME & COVER VB 7160 FROM CAPITAL FOUNDRY OF VIRGINIA.
2. ALL FITTINGS INSIDE OF HRSD VALVE VAULT SHALL BE 2" NPT.

NOT TO SCALE

	<b>STANDARD DESIGN DETAIL</b>	DRAWING NO. 306A
	<b>2" PRIVATE CONNECTION TO EXISTING 2" HRSD STUB</b>	SHEET 1 OF 3
		DATE 9/2018

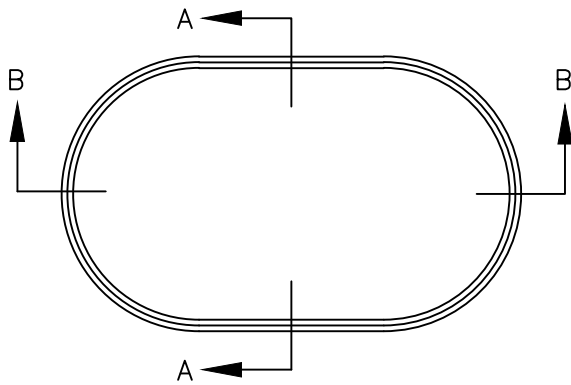

PLAN: VAULT

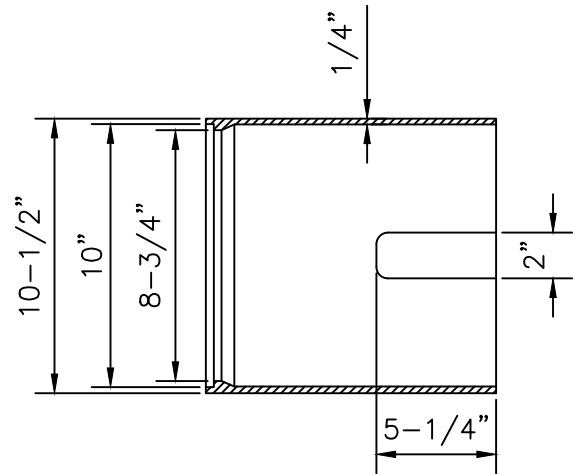

SECTION A-A

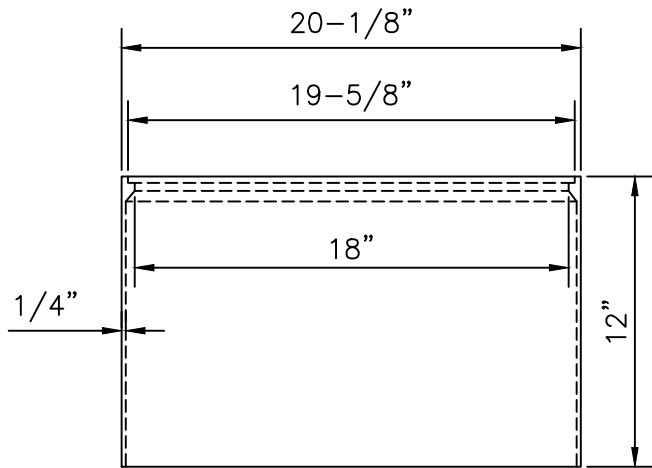

SECTION B-B

NOTES:

1. VALVE VAULT TO BE SUPPLIED BY CAPITAL FOUNDRY OF VIRGINIA, INC. (MODEL #MBX-1) OR APPROVED EQUAL.
2. ALL GRAY IRON CASTINGS SHALL CONFORM TO LATEST EDITION OF ASTM A-48, CLASS 30 AND SHALL BE OF UNIFORM QUALITY.
3. ALL CASTING DIMENSIONS SHALL HAVE A TOLERANCE OF 1/8"±.
4. ALL CASTINGS SHALL BE CLEANED BY SHOT BLASTING AND HAND CHIPPING UTILIZING STANDARD INDUSTRY PRACTICES PRIOR TO SHOP APPLICATION OF ASPHALTIC COATING, BY DIPPING.

NOT TO SCALE

	STANDARD DESIGN DETAIL	DRAWING NO. 306B
	VALVE VAULT FOR 2" HRSD VALVE	SHEET 2 OF 3
		DATE 9/2018



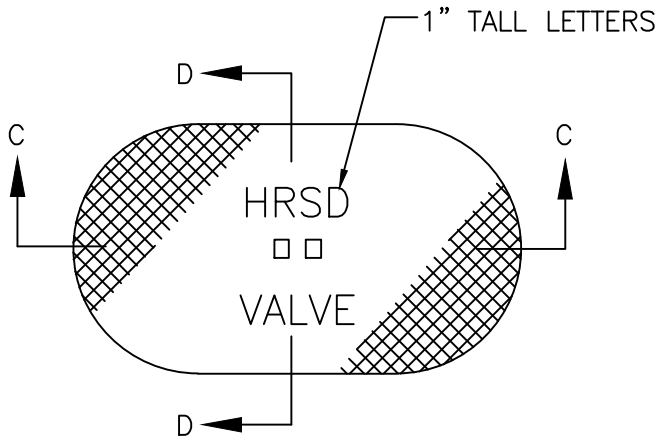

PLAN: LID

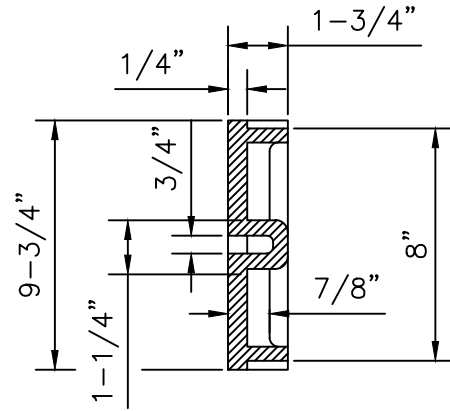

SECTION D-D

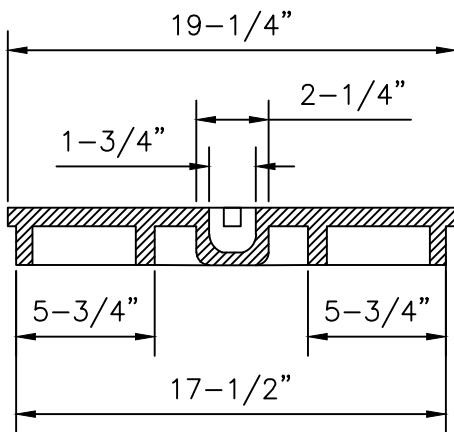

SECTION C-C

NOT TO SCALE



STANDARD DESIGN DETAIL

VAULT LID FOR 2" HRSD VALVE

DRAWING NO.  
306C

SHEET  
3 OF 3

DATE  
9/2018

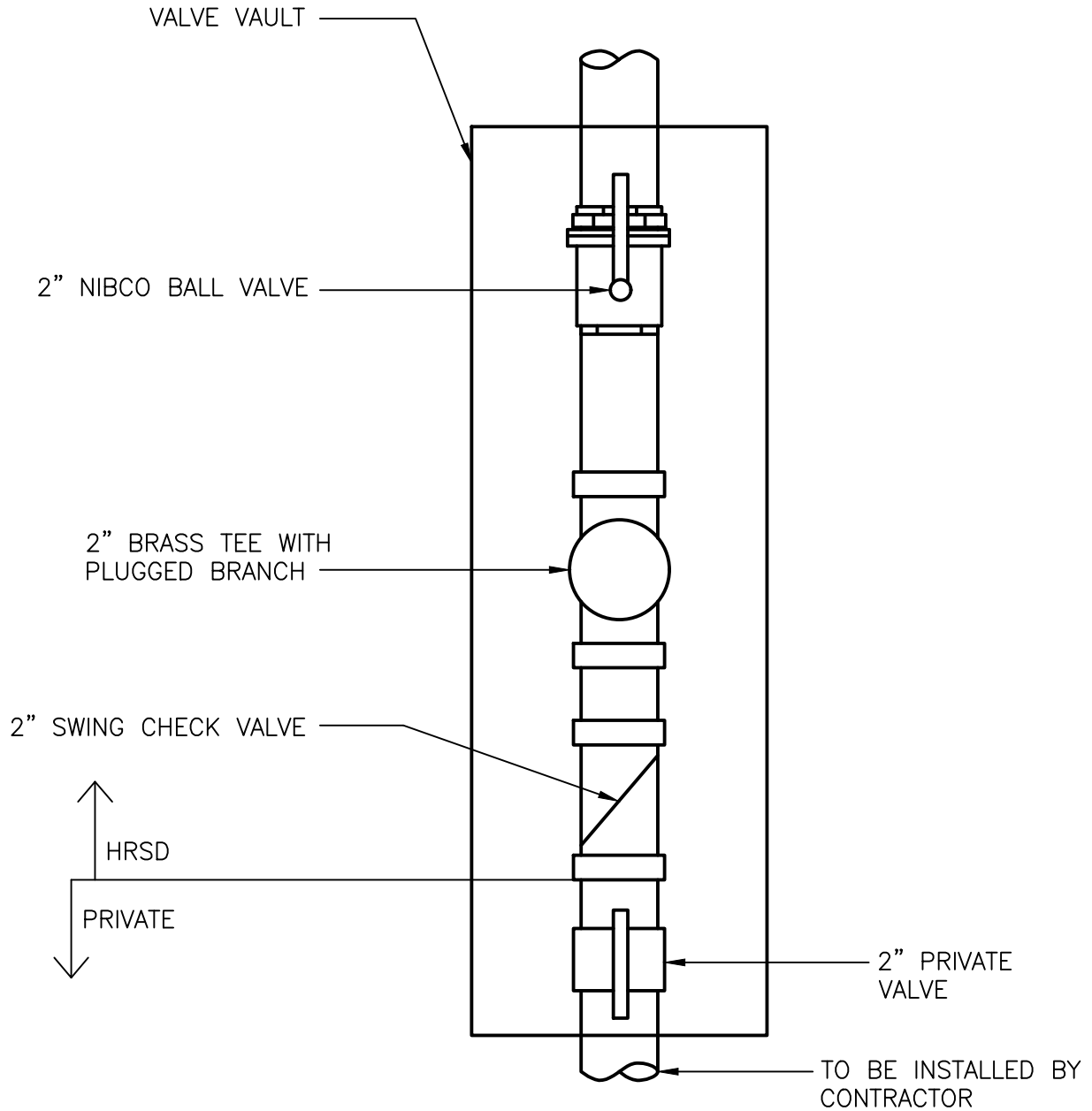

NOTES:

1. TRACER WIRE CAN BE TERMINATED INSIDE OF VALVE VAULT.
2. ALL FITTINGS AND PIPING TO BE BRASS WITH THREADED ENDS WITHIN THE VALVE VAULT.
3. OPERATION OF HRSD VALVES SHALL BE DONE BY HRSD PERSONNEL ONLY.
4. DEVIATION FROM THIS DETAIL WILL REQUIRE APPROVAL FROM HRSD.

NOT TO SCALE

	STANDARD DESIGN DETAIL	DRAWING NO. 307
	LAWNES POINT PRIVATE CONNECTION DETAIL	SHEET 1 OF 1
		DATE 9/2018

PRIVATELY OWNED GRINDER PIT (MUST HAVE CHECK VALVE FOLLOWED BY ISOLATION VALVE ON DISCHARGE PIPING)

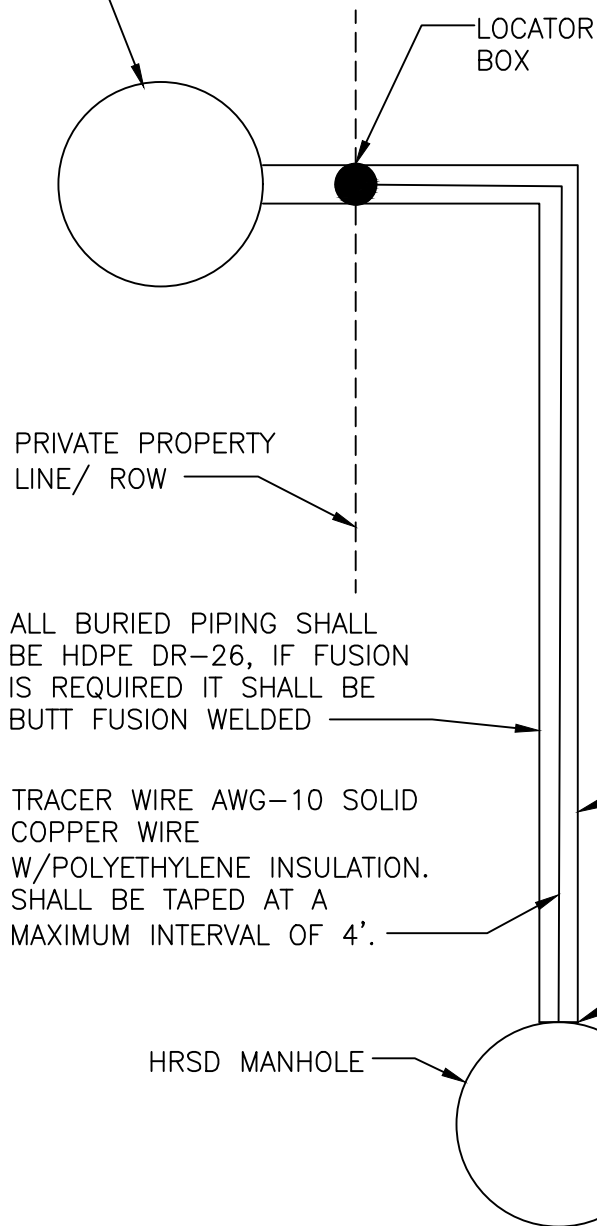

PRIVATE PROPERTY LINE/ ROW

ALL BURIED PIPING SHALL BE HDPE DR-26, IF FUSION IS REQUIRED IT SHALL BE BUTT FUSION WELDED

TRACER WIRE AWG-10 SOLID COPPER WIRE W/POLYETHYLENE INSULATION. SHALL BE TAPED AT A MAXIMUM INTERVAL OF 4'.

HRSD MANHOLE

LOCATOR BOX

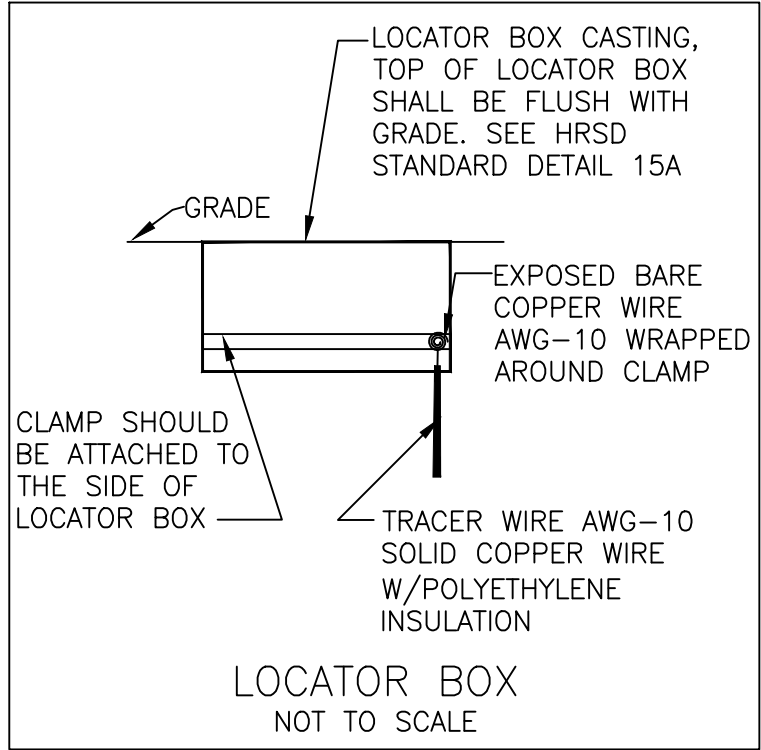

LOCATOR BOX CASTING, TOP OF LOCATOR BOX SHALL BE FLUSH WITH GRADE. SEE HRSD STANDARD DETAIL 15A

GRADE

EXPOSED BARE COPPER WIRE AWG-10 WRAPPED AROUND CLAMP

CLAMP SHOULD BE ATTACHED TO THE SIDE OF LOCATOR BOX

TRACER WIRE AWG-10 SOLID COPPER WIRE W/POLYETHYLENE INSULATION

LOCATOR BOX NOT TO SCALE

PIPE DIAMETER SHALL BE MAX 4"

SEE FORCE MAIN DETAIL FOR EITHER EXTERNAL/INTERNAL DROP

\*IF CONNECTING TO HRSD FORCE MAIN REFERENCE HRSD STANDARD DETAIL 328

NOT TO SCALE



STANDARD DESIGN DETAIL

PRIVATE FORCE MAIN TO HRSD ASSET

DRAWING NO.	308
SHEET	1 OF 1
DATE	9/2018

EXISTING GRADE OR PAVEMENT

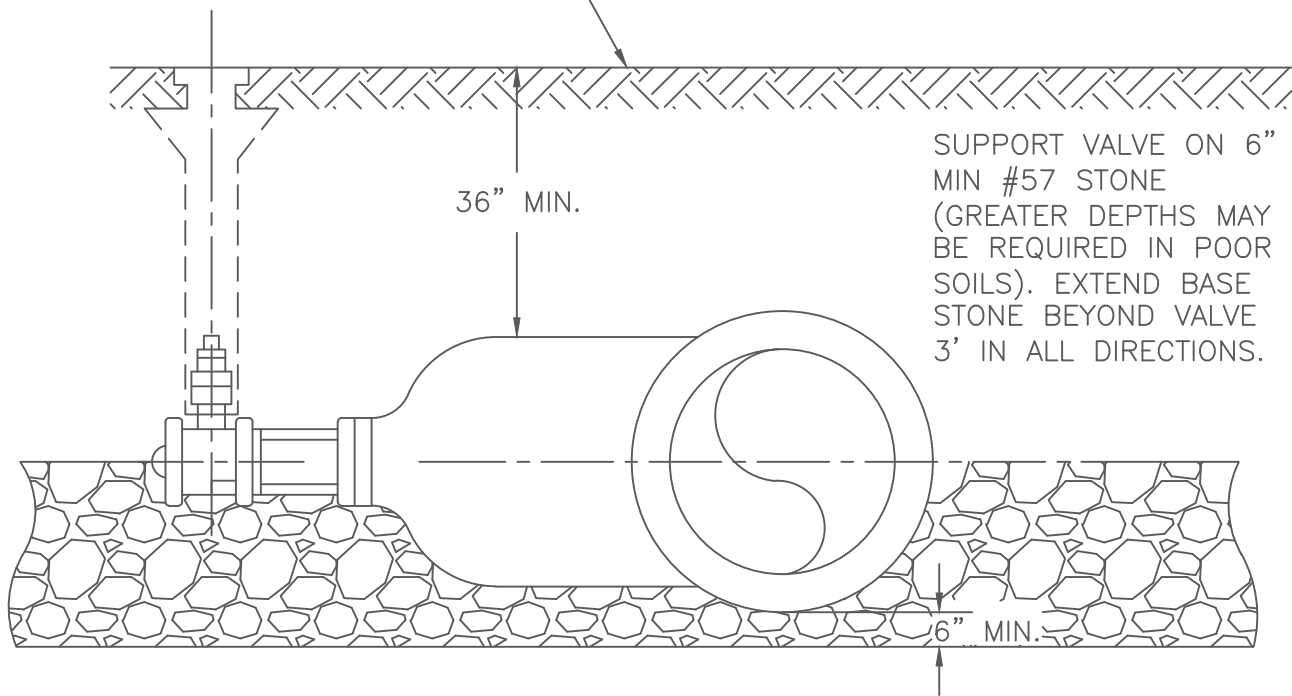

SUPPORT VALVE ON 6" MIN #57 STONE (GREATER DEPTHS MAY BE REQUIRED IN POOR SOILS). EXTEND BASE STONE BEYOND VALVE 3' IN ALL DIRECTIONS.

36" MIN.

6" MIN.

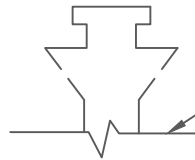

VALVE BOX & RISER  
SEE HRSD STANDARD  
DETAIL #11

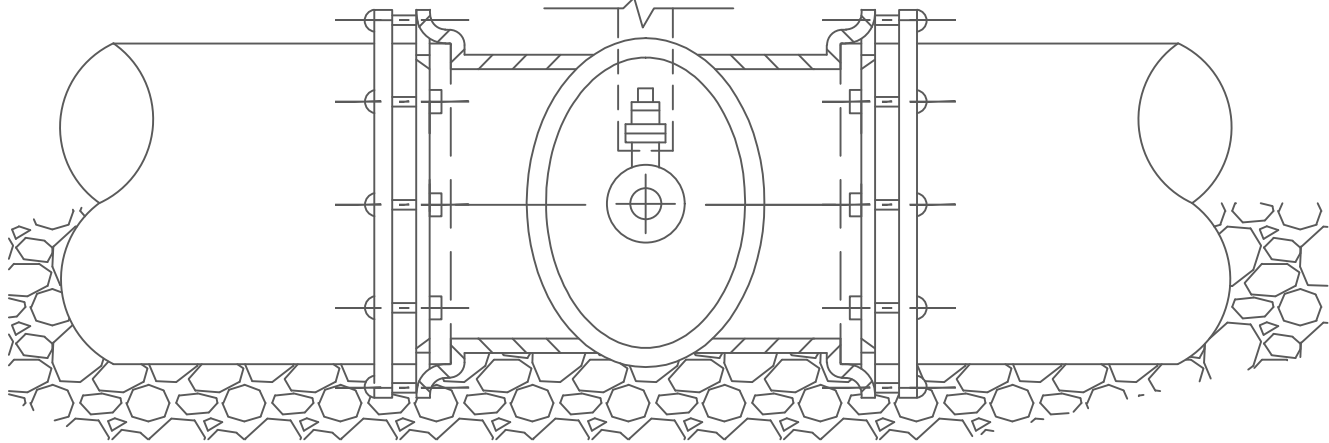

NOTE:

1. SEE SPECIFICATIONS FOR HORIZONTAL OR VERTICAL POSITION AND BY-PASS REQUIREMENT.
2. EXTENSION STEMS ARE NOT ACCEPTABLE.
3. INSTALL CRIBBING AS NECESSARY.

NOT TO SCALE



STANDARD DESIGN DETAIL

HORIZONTAL GATE VALVE

DRAWING NO.

326

SHEET

1 OF 1

DATE

9/2018

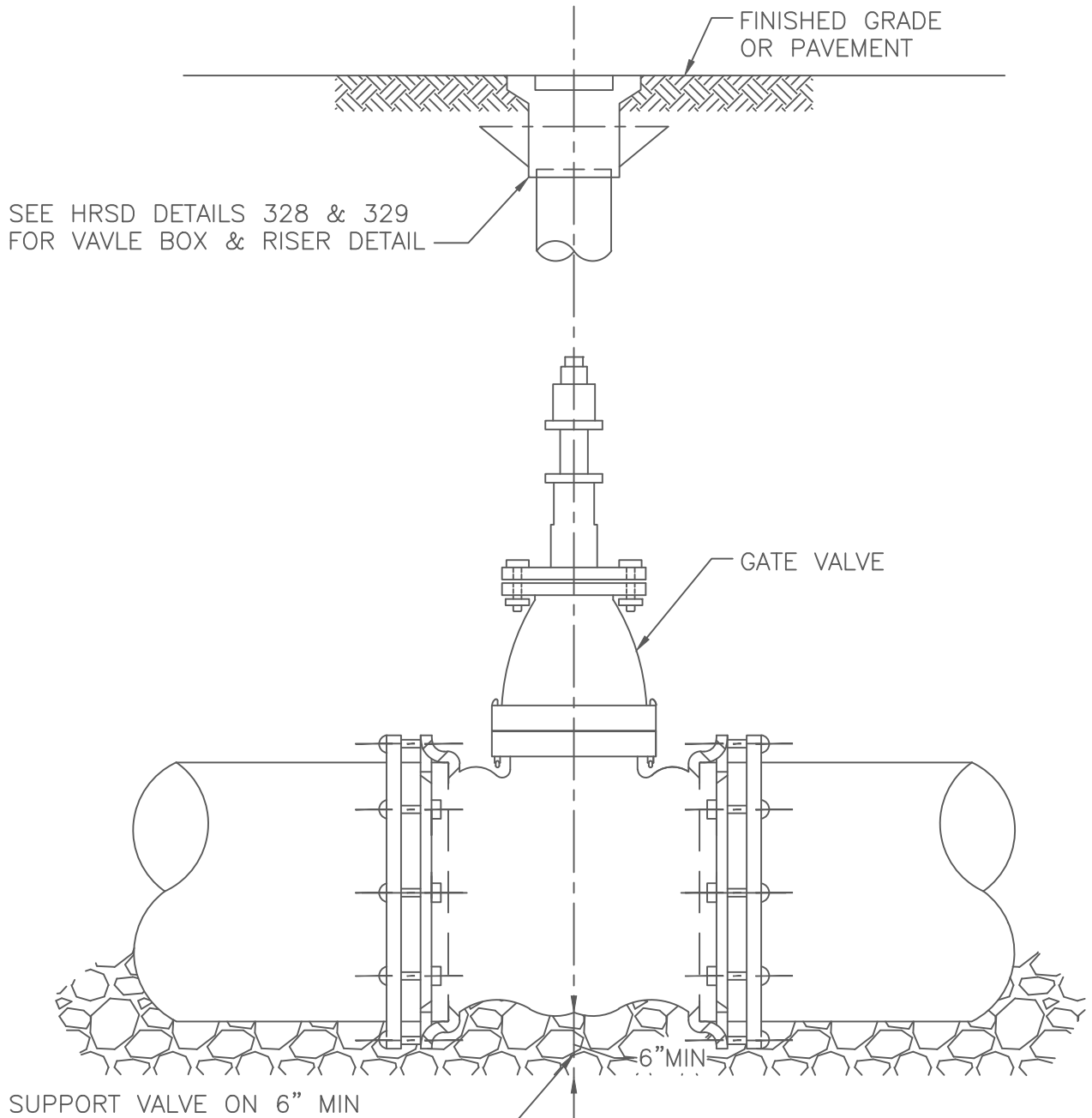

SEE HRSD DETAILS 328 & 329  
FOR VAVLE BOX & RISER DETAIL

SUPPORT VALVE ON 6" MIN  
#57 STONE (GREATER DEPTHS  
MAY BE REQUIRED IN POOR  
SOILS). EXTEND BASE BEYOND  
VALVE 3' IN ALL DIRECTIONS.

**NOTE:**

1. SEE SPECIFICATIONS FOR HORIZONTAL OR VERTICAL POSITION AND BYPASS REQUIREMENT.
2. EXTENSION SYSTEMS ARE NOT ACCEPTABLE.
3. INSTALL CRIBBING AS NECESSARY.
4. THIS DETAIL ONLY APPLICABLE FOR VALVES 14" AND SMALLER.
5. MINIMUM VALVE SIZE SHALL BE 8".

NOT TO SCALE

	STANDARD DESIGN DETAIL	DRAWING NO. <b>327</b>
	VERTICAL GATE VALVE	SHEET <b>1 OF 1</b>
		DATE <b>9/2018</b>

MINIMUM WEIGHTS:  
 COVER - 22 LBS.  
 FRAME - 110 LBS.

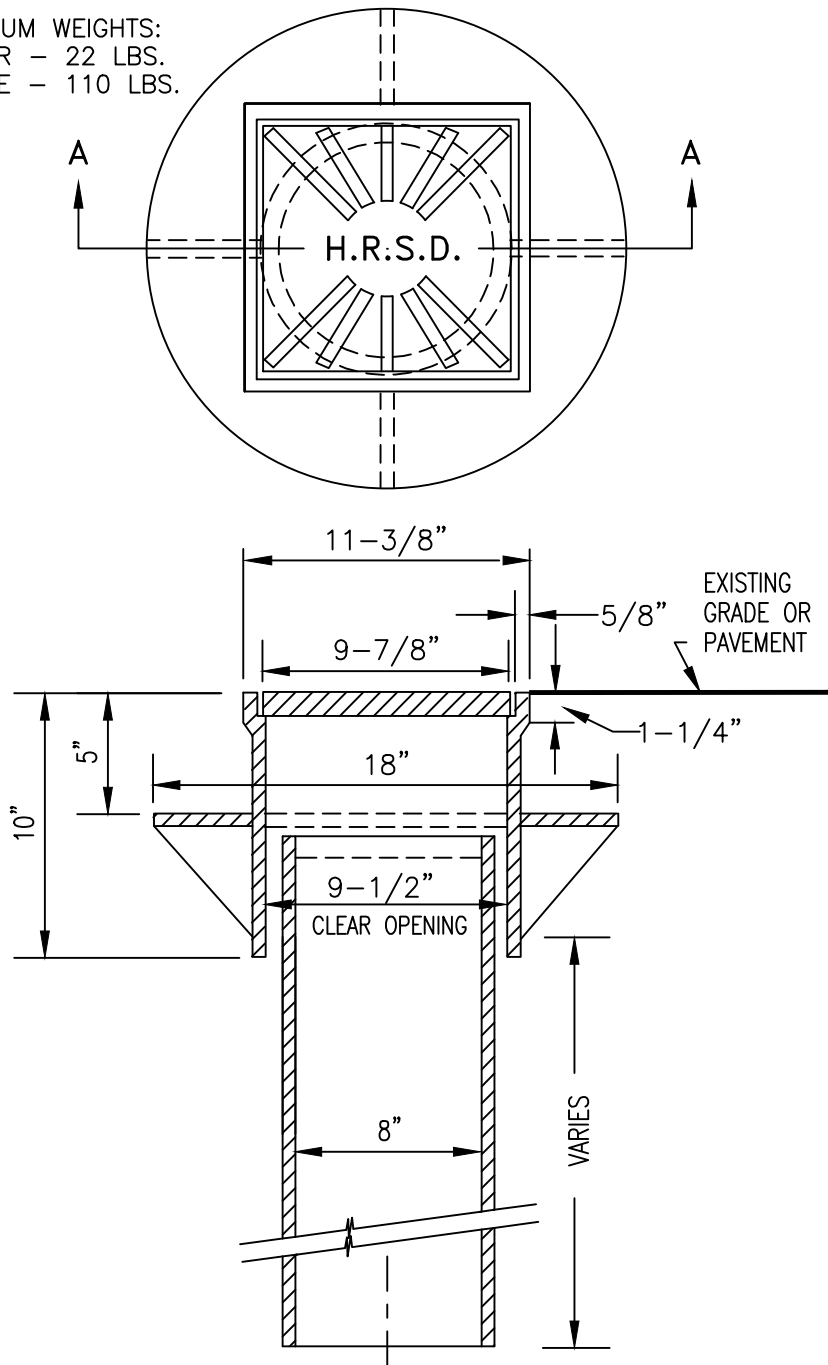

SECTION A-A

NOTES:

1. RISER TO BE 8" C900 PVC OR 8" SCH. 80 PVC. (ONE PIECE).  
 BELL END PIECE SHALL NOT BE ALLOWED.
2. TOLERANCE TO BE +/- .125" FOR ALL DIMENSIONS.
3. CASTING TO BE SHOT BLASTED.
4. CASTING TO BE ASTM A-48 CLASS 30.
5. JACK UP RINGS NOT ACCEPTABLE.
6. TOP OF RISER PIPE SHALL BE 5" BELOW THE LIP FOR THE CASTING LID.
7. RISER SHALL BE CENTERED ON THE FORCE MAIN AND SHALL BE PLUMB AND STRAIGHT.

NOT TO SCALE



STANDARD DESIGN DETAIL

VALVE BOX & RISER FOR MAINLINE  
 TRACER WIRE BOX

DRAWING NO.

328

SHEET

1 OF 1

DATE

9/2018

MINIMUM WEIGHTS:  
 COVER - 25 LBS.  
 FRAME - 75 LBS.

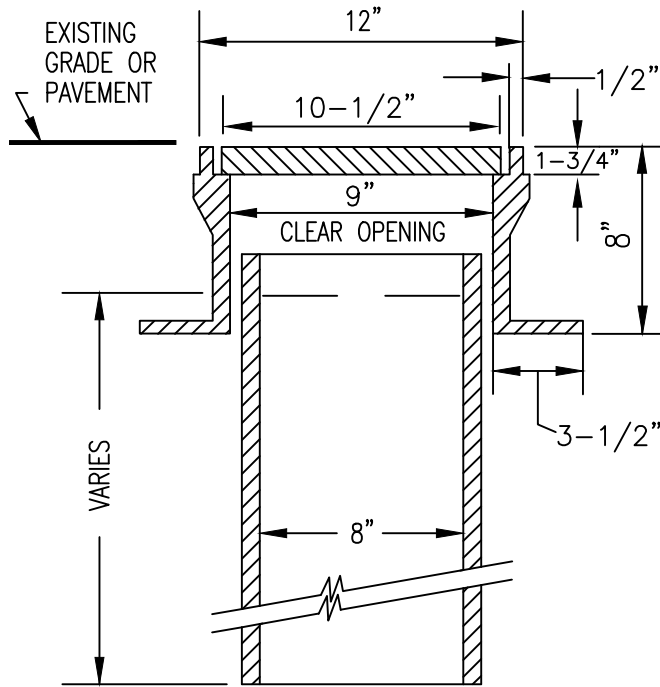
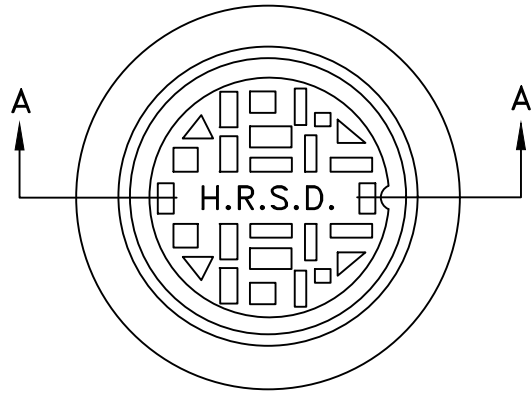

SECTION A-A

NOTES:

1. RISER TO BE 8" C900 PVC OR 8" SCH. 80 PVC. (ONE PIECE).  
BELL END PIECE SHALL NOT BE ALLOWED.
2. TOLERANCE TO BE +/- .125" FOR ALL DIMENSIONS.
3. CASTING TO BE SHOT BLASTED.
4. CASTING TO BE ASTM A-48 CLASS 30.
5. JACK UP RINGS NOT ACCEPTABLE.
6. TOP OF RISER PIPE SHALL BE 5" BELOW THE LIP FOR THE CASTING LID.
7. RISER SHALL BE CENTERED ON THE NUT AND SHALL BE PLUMB AND STRAIGHT.

NOT TO SCALE



STANDARD DESIGN DETAIL

VALVE BOX & RISER FOR BYPASS VALVES

DRAWING NO.

329

SHEET

1 OF 1

DATE

9/2018

MINIMUM WEIGHTS:  
 COVER - 22 LBS.  
 FRAME - 110 LBS.

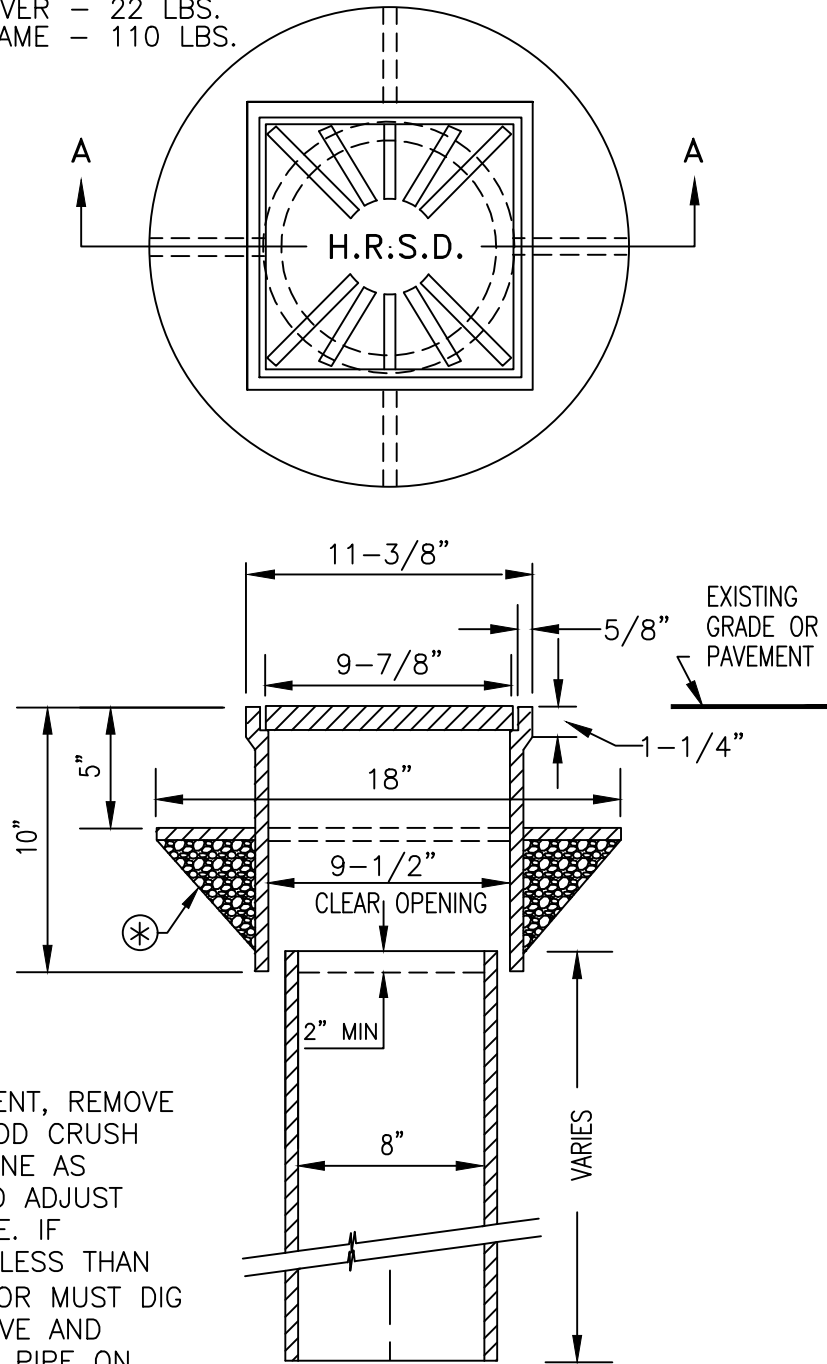

⊛ FOR ADJUSTMENT, REMOVE FRAME AND ADD CRUSH AND RUN STONE AS NECESSARY TO ADJUST TOP TO GRADE. IF INSERTION IS LESS THAN 2", CONTRACTOR MUST DIG DOWN ON VALVE AND ADJUST RISER PIPE ON VALVE BY ADDING STONE OR NEW 8" PIPE OF APPROPRIATE LENGTH.

SECTION A-A  
 FOR USE ON MAINLINE  
 OR CONNECTION VALVES

NOT TO SCALE



STANDARD DESIGN DETAIL

VALVE RISER ADJUSTMENT

DRAWING NO.  
 330

SHEET  
 1 OF 1

DATE  
 9/2018



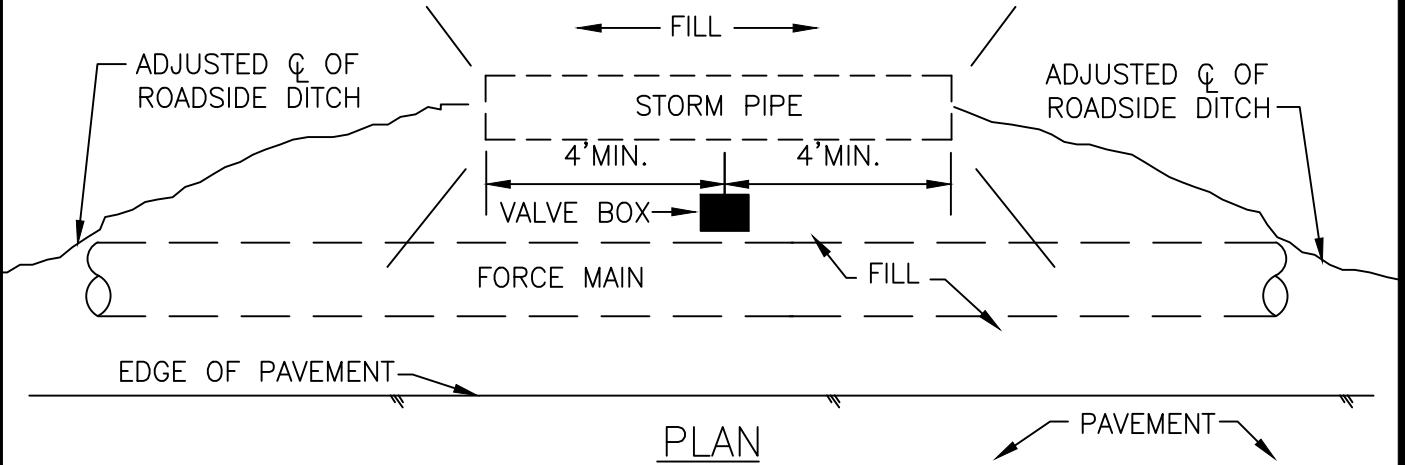
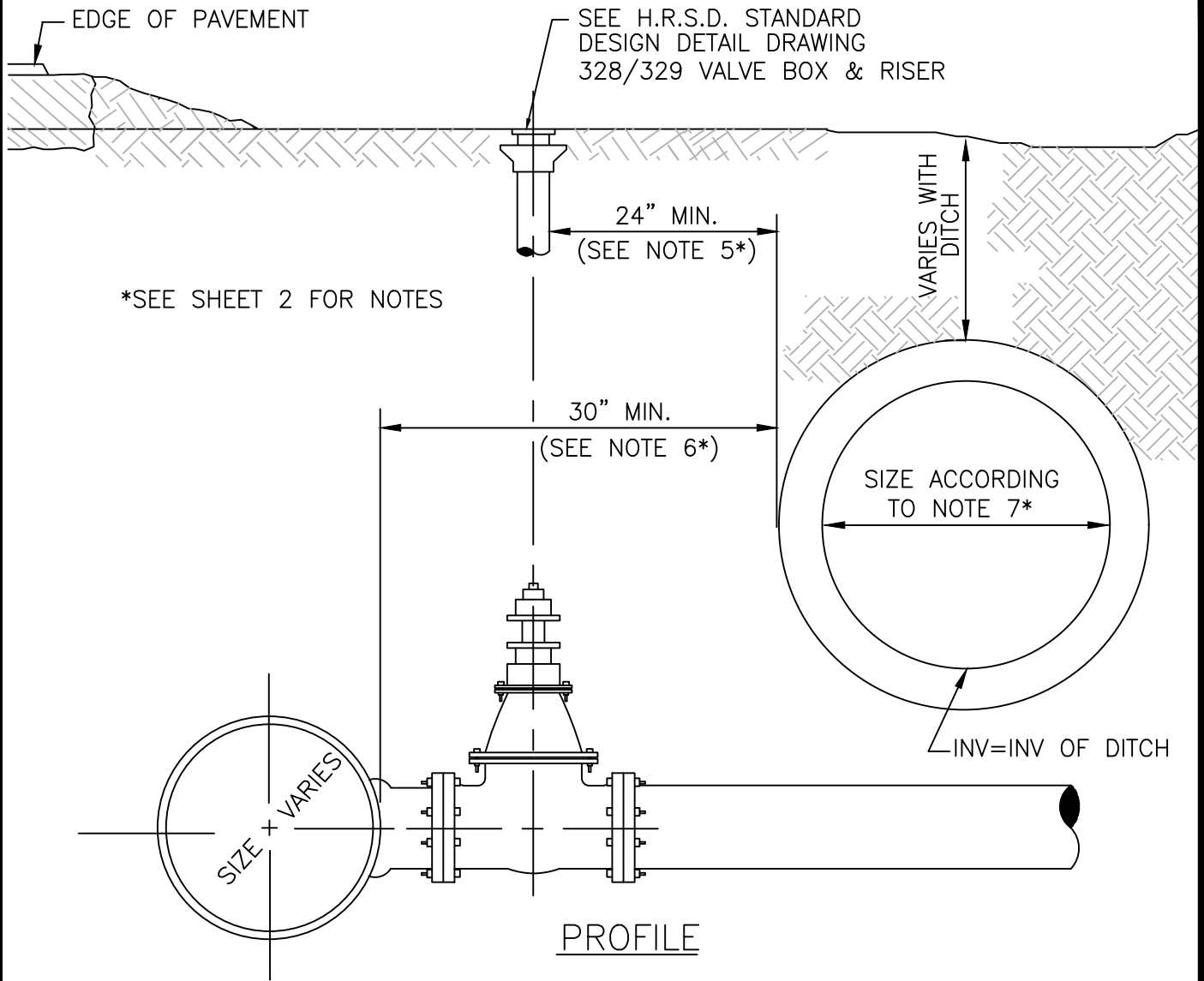

NOT TO SCALE

	STANDARD DESIGN DETAIL	DRAWING NO. 331A
	ROADSIDE DITCH-VALVE BOX	SHEET 1 OF 2
		DATE 9/2018

NOTES:

1. VALVE BOXES ARE TO BE ALIGNED TRUE AND SQUARE WITH EDGE OF PAVEMENT.
2. STORM PIPE SHALL EXTEND A MINIMUM OF FOUR (4) FEET TO EITHER SIDE OF VALVE BOX.
3. FILL MATERIAL SHALL CONFORM TO RIGHT OF WAY PERMIT REQUIREMENTS.
4. SLOPE FILL MATERIAL TO DRAIN AWAY FROM VALVE BOX TOWARDS DITCH.
5. MAINTAIN 24 INCH MINIMUM HORIZONTAL DISTANCE BETWEEN STORM PIPE AND VALVE RISER PIPE.
6. WHEN VALVE FACES AWAY FROM DITCH, MAINTAIN 30 INCH MINIMUM HORIZONTAL DISTANCE BETWEEN STORM PIPE AND FORCE MAIN.
7. STORM PIPE SHALL BE SIZED IN ACCORDANCE WITH RIGHT OF WAY PERMIT.
8. UPON COMPLETION OF VALVE BOX AND STORM PIPE INSTALLATION, CONTACT HRSD INSPECTOR FOR FINAL INSPECTION.

	STANDARD DESIGN DETAIL	DRAWING NO. 331B
	ROADSIDE DITCH-VALVE BOX	SHEET 2 OF 2
		DATE 9/2018

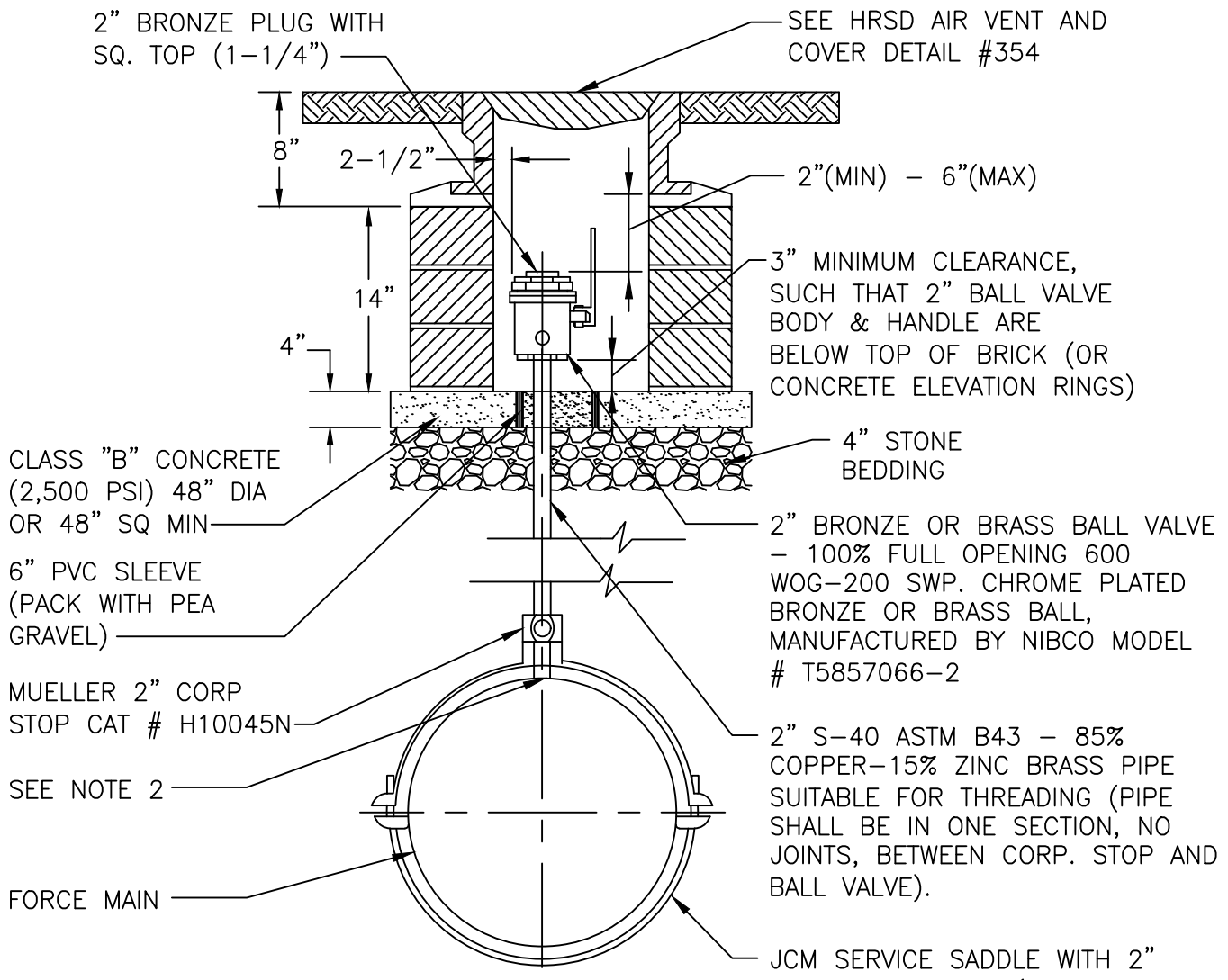

NOTE: HANDLE AS SHOWN IS VALVE INSTALLED IN OPEN POSITION

JCM SERVICE SADDLE WITH 2" THREADED OUTLET (MUELLER CC THREADS). STYLE 404 FOR PIPE 24" DIA AND LESS, STYLE 418 FOR PIPE GREATER THAN 24", AND STYLE 425 FOR ALL PCCP ONLY. NO SUBSTITUTIONS WILL BE ACCEPTED WITHOUT HRSD OPERATIONS APPROVAL.

**NOTES:**

1. CONSTRUCT AIR VENT USING REQUIRED NUMBER OF COURSES OF HARD SOUND COMMON BRICK LAID ON EDGE OR CONCRETE ELEVATION RINGS AS MANUFACTURED BY NANSEMOND PRE-CAST CONCRETE CO, INC. MODEL AV-ER-CH AND AV-BS.
2. 2" TAP FOR AIR VENT SHALL BE STANDARD SADDLE TAP.
3. SERVICE SADDLE COATING SHALL BE FUSION BONDED EPOXY. SADDLE STRAPS AND HARDWARE SHALL BE STAINLESS STEEL. STAINLESS STEEL SHALL BE MINIMUM 304.
4. JACK UP RINGS BETWEEN THE FRAME AND COVER NOT ACCEPTABLE.
5. PARGE BRICK WORK OR CONCRETE ELEVATION RINGS WITH GROUT INSIDE AND OUT, CONTINUE ONTO CASTING.

NOT TO SCALE

	STANDARD DESIGN DETAIL	DRAWING NO. 351
	AIR VENT	SHEET 1 OF 1
		DATE 09/2018

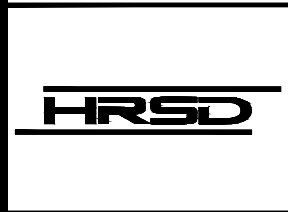
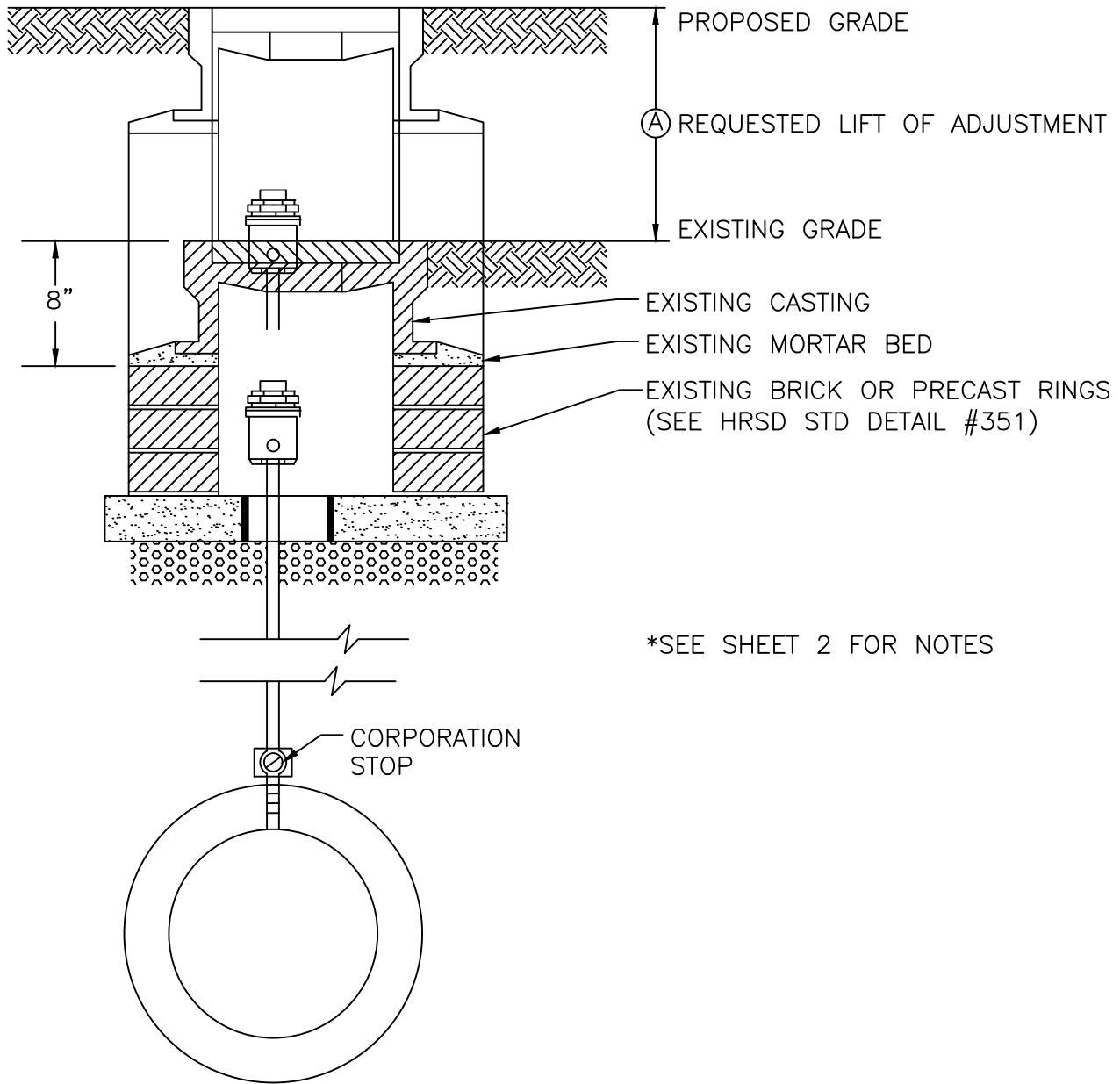

STANDARD DESIGN DETAIL

AIR RELEASE VALVE BOX ADJUSTMENT

DRAWING NO.	352A
SHEET	1 OF 2
DATE	9/2018

GENERAL ADJUSTMENT NOTES:

1. REFER TO HRSD STD. DETAIL #351 FOR TYPICAL AIR VENT VALVE BOX CONSTRUCTION.
2. REFER TO HRSD STD. DETAIL #354 FOR AIR VENT VALVE BOX CASTING LID AND FRAME (IF CASTING ON SITE IS NOT AS SHOWN IN DETAIL #354, NOTIFY HRSD ENGINEER).
3. TOP OF VALVE'S BRONZE PLUG SHALL BE NO CLOSER TO BOTTOM OF FRAME THAN TWO (2") INCHES NOR FARTHER THAN SIX (6") INCHES.
4. BED CAST IRON FRAME SOUNDLY IN MORTAR GROUT.
5. PARGE ENTIRE VALVE BOX (INSIDE & OUT) WITH GROUT.

LOWERING TO GRADE:

6. EXCAVATE TO CORPORATION STOP AND CLOSE IT.
7. REMOVE AND REPLACE BALL VALVE AND RISER PIPE.
8. OPEN CORPORATION STOP 100%. MODIFY/RECONSTRUCT BOX AS REQUIRED.

RAISING OF GRADE:

9. WHEN ADJUSTMENT "A" DOES NOT VIOLATE NOTE #3, ABOVE, CASTING MAY BE LIFTED BY REMOVING EXISTING MORTAR BED AND ADDING COURSES OF HARD, SOUND, COMMON BRICK OR CONCRETE ELEVATION RINGS.
10. WHEN ADJUSTMENT "A" VIOLATES NOTE #3, FOLLOW STEPS 6-8 ABOVE.

	STANDARD DESIGN DETAIL	DRAWING NO. 352B
		SHEET 2 OF 2
	AIR RELEASE VALVE BOX ADJUSTMENT	DATE 9/2018

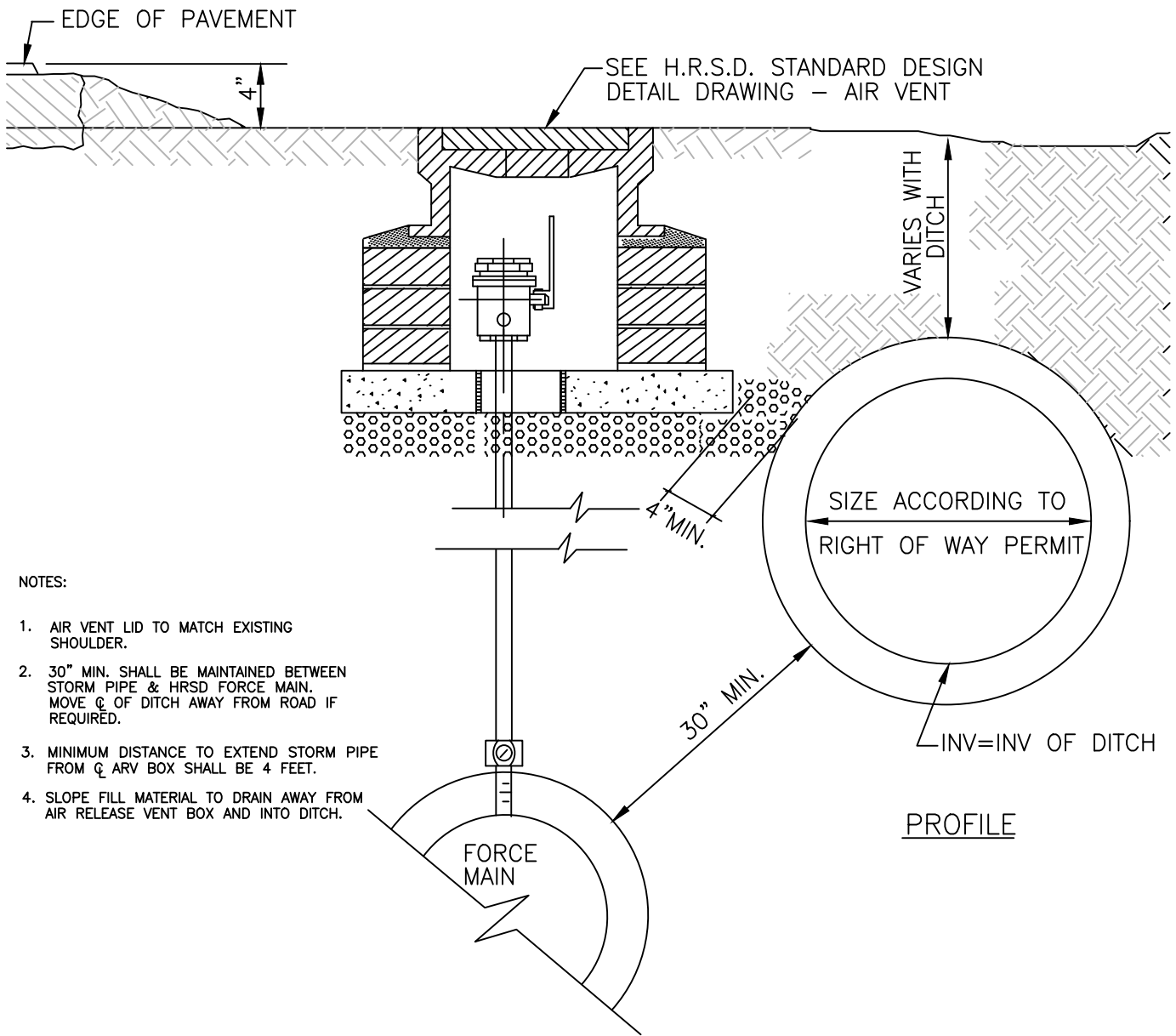

NOTES:

1. AIR VENT LID TO MATCH EXISTING SHOULDER.
2. 30" MIN. SHALL BE MAINTAINED BETWEEN STORM PIPE & HRSD FORCE MAIN. MOVE  $\phi$  OF DITCH AWAY FROM ROAD IF REQUIRED.
3. MINIMUM DISTANCE TO EXTEND STORM PIPE FROM  $\phi$  ARV BOX SHALL BE 4 FEET.
4. SLOPE FILL MATERIAL TO DRAIN AWAY FROM AIR RELEASE VENT BOX AND INTO DITCH.

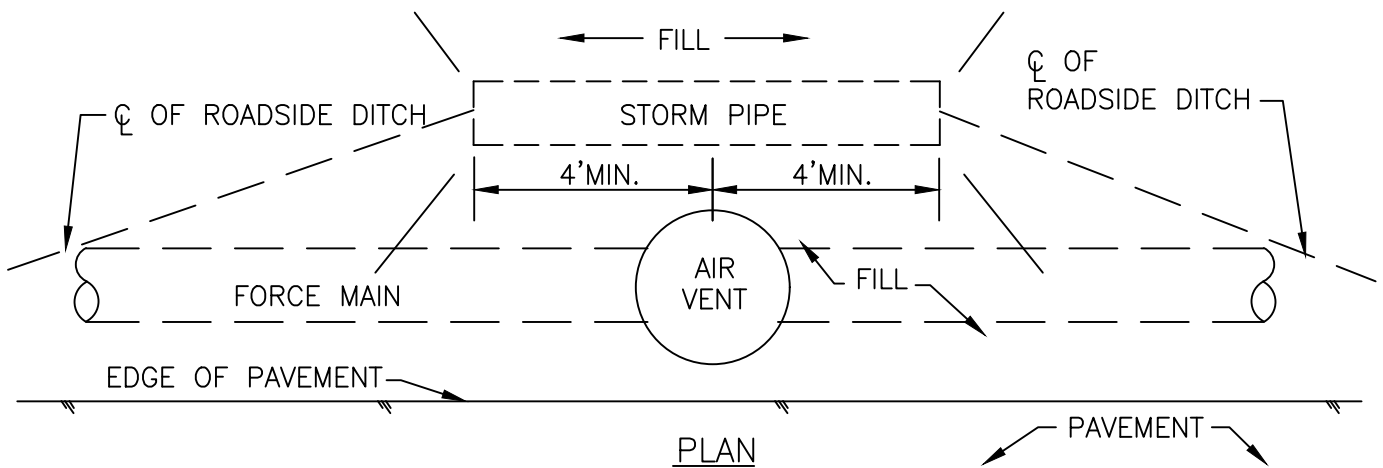

NOT TO SCALE

	STANDARD DESIGN DETAIL	DRAWING NO. <b>353</b>
	ROADSIDE DITCH-AIR VENT	SHEET <b>1 OF 1</b>
		DATE <b>9/2018</b>

NOTES

1. MACHINE ALL SEATING SURFACES ON BOTH COVER & FRAME
2. TOLERANCE TO BE  $\pm 0.125$ " FOR ALL DIMENSIONS.
3. CASTING TO BE SHOT BLASTED.
4. CASTING TO BE ASTM A-48 CLASS 30.
5. MINIMUM WEIGHTS:  
FRAME- 114 LBS.  
COVER- 50 LBS.
6. JACK UP RINGS NOT ACCEPTABLE.

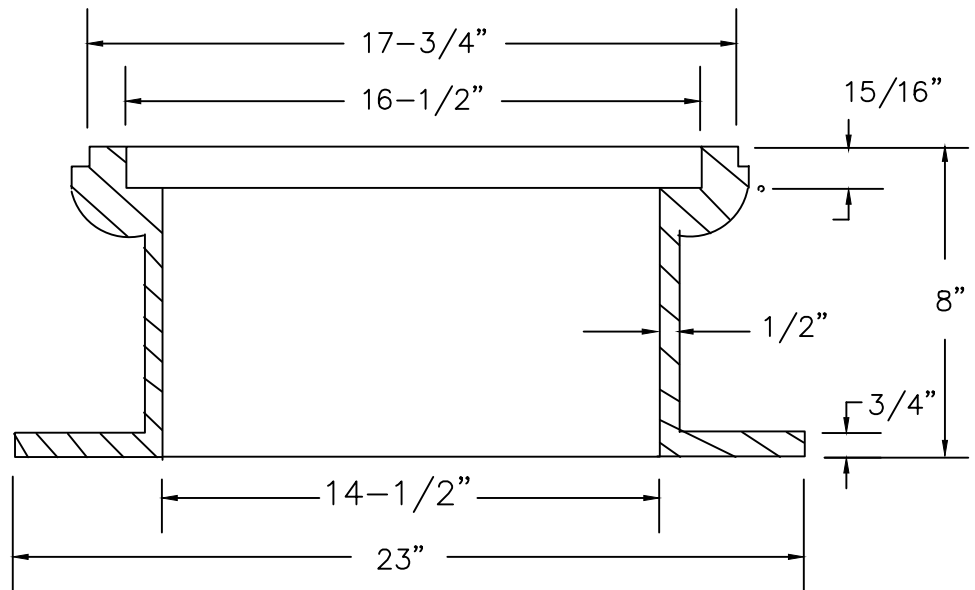
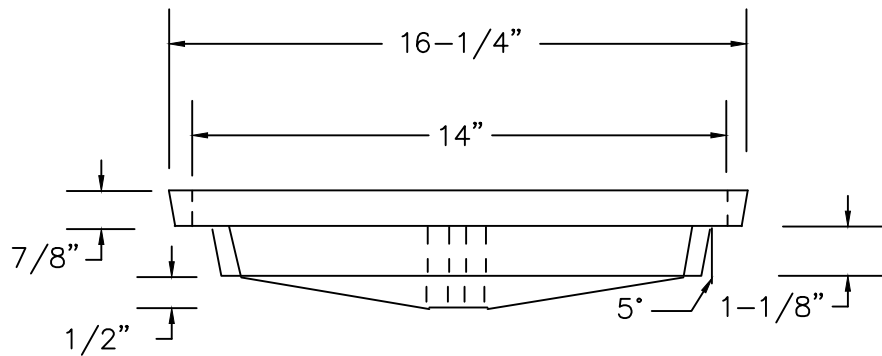
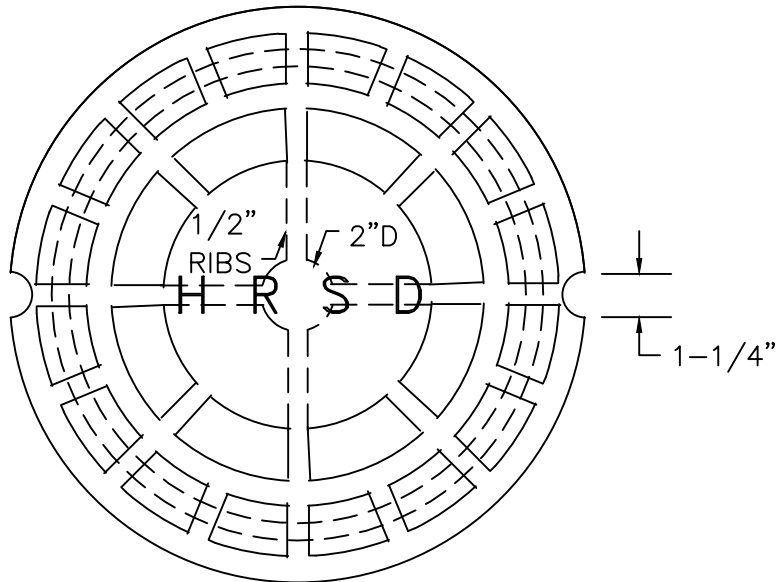

NOT TO SCALE



STANDARD DESIGN DETAIL

AIR VENT FRAME & COVER

DRAWING NO.

354

SHEET

1 OF 1

DATE

9/2018

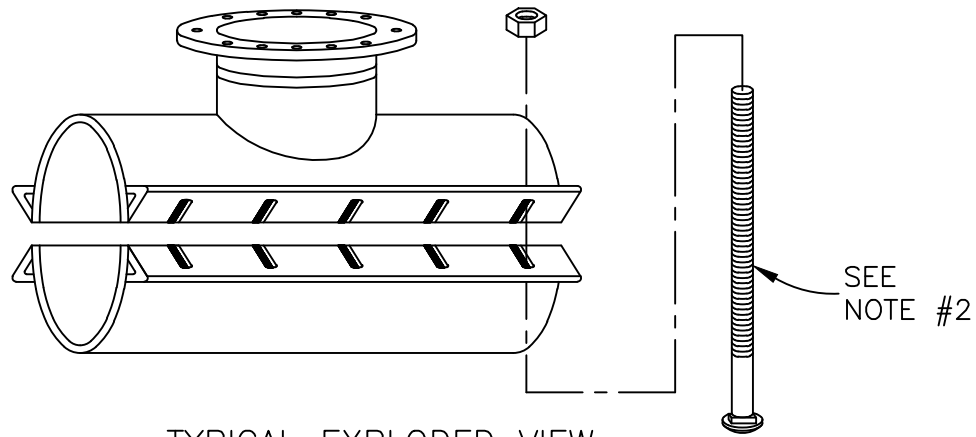

TYPICAL EXPLODED VIEW  
SEE NOTE #1

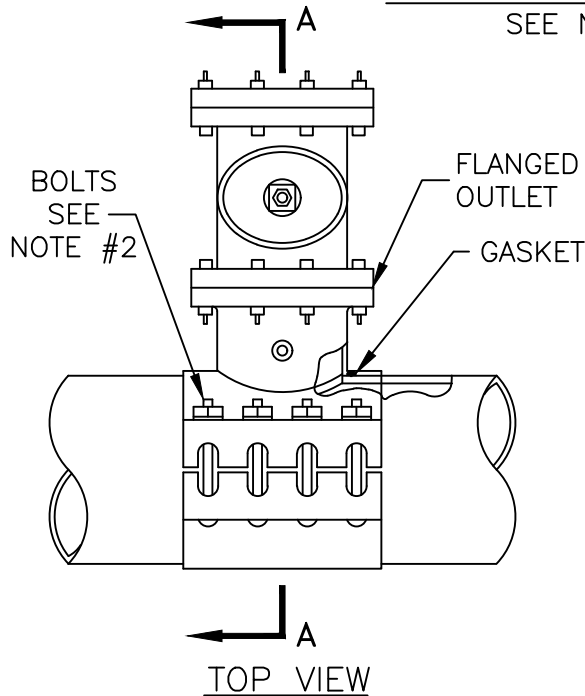

TOP VIEW

IBBM TYPE TAPPING  
VALVE W/ 2" SQ. NUT  
(SEE NOTE #4)

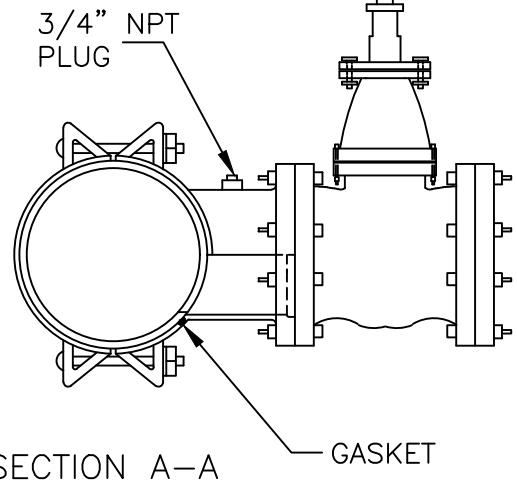

SECTION A-A

NOTES:

1. FULL BACK SADDLES ONLY, EXCEPT IN ACCORDANCE WITH PIPE MANUFACTURER'S RECOMMENDATIONS FOR SP-5 AND SP-12 (SEE H.R.S.D. STANDARD DESIGN DETAIL #377 - TAPPING SADDLE FOR CONC. CYLINDER PIPE).
2. THE NUMBER, SPACING, SIZE AND INSTALLATION OF BOLTS SHALL BE IN ACCORDANCE WITH SADDLE MANUFACTURER'S RECOMMENDATIONS.
3. CONTRACTOR SHALL SUPPLY TO HAMPTON ROADS SANITATION DISTRICT SYSTEMS ENGINEER THREE (3) CLEAR COPIES OF TAPPING SADDLE MANUFACTURER'S CATALOG CUT AND INSTALLATION INSTRUCTIONS 14 DAYS PRIOR TO INSTALLATION OF SADDLE.
4. TAPPING VALVE TO MEET ANSI/AWWA STANDARDS C500, C509 OR C515.
5. ALL BOLTS, NUTS AND WASHERS SHALL BE STAINLESS STEEL.
6. SADDLE COATING SHALL BE FUSION BONDED EPOXY.
7. TAPPING SADDLE MANUFACTURER SHALL BE SMITH-BLAIR STYLE 622 OR HRSD APPROVED EQUAL.

NOT TO SCALE



STANDARD DESIGN DETAIL

TAPPING SADDLE FOR  
CAST IRON PIPE, DUCTILE IRON, RC, & PVC PIPE

DRAWING NO. 376
SHEET 1 OF 1
DATE 9/2018



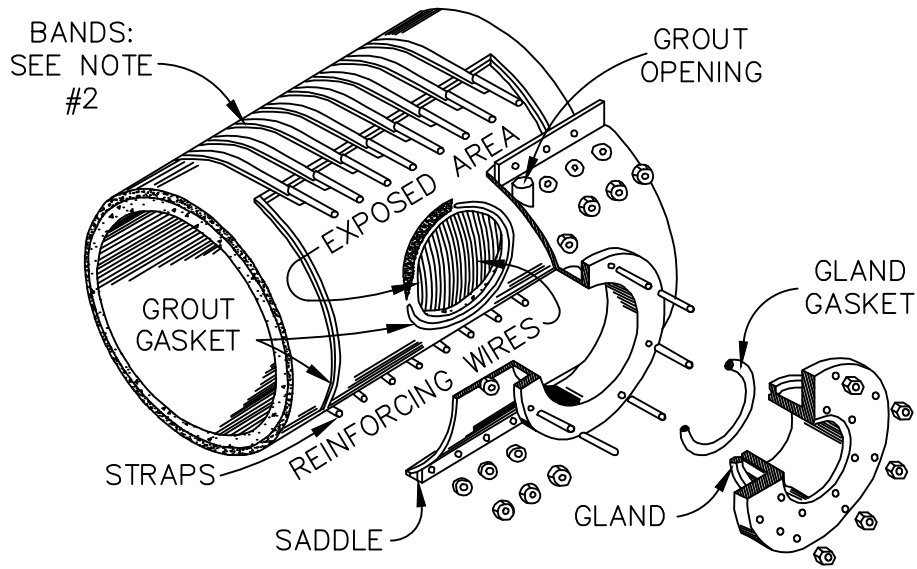

TYPICAL EXPLODED VIEW  
SEE NOTE #1

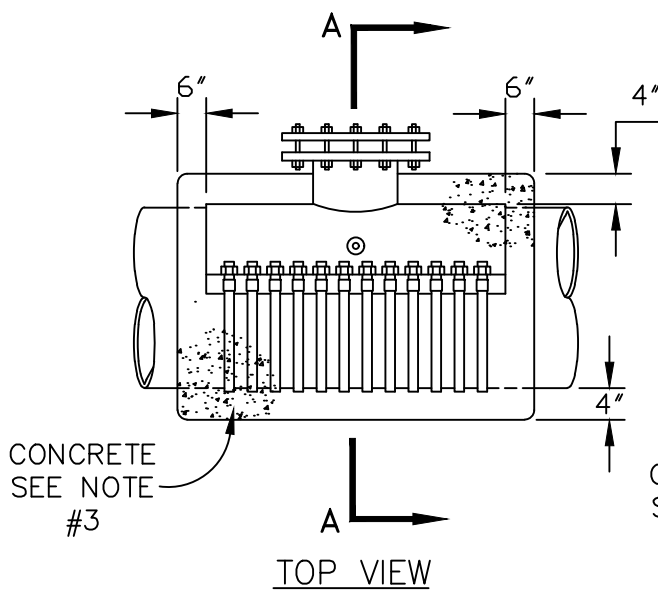

TOP VIEW

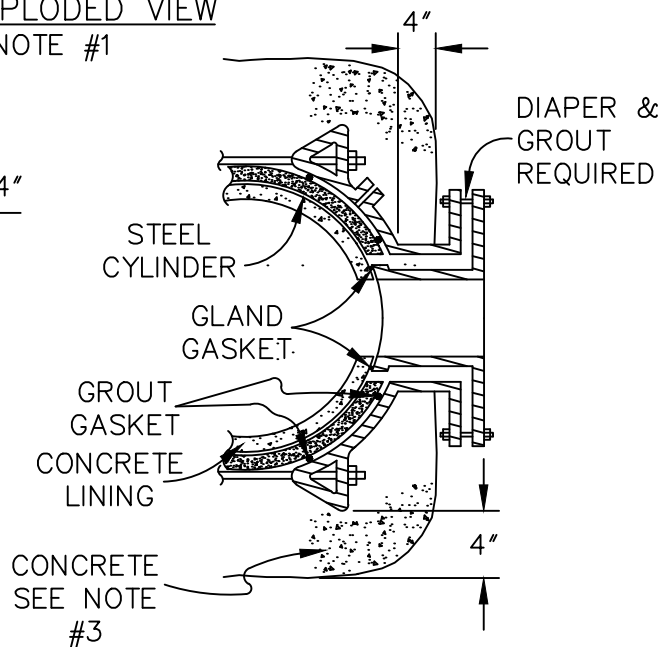

SECTION A-A

NOTES:

1. Banded tapping saddles only accepted on SP-5 & SP-12 pipe per pipe manufacturer's recommendations (see standard design detail #12 - standard tapping saddle for cast iron pipe, ductile iron, RC, & PVC pipe).
2. The number, spacing, size and installation of bands shall be in accordance with saddle manufacturer's recommendations.
3. All tapping saddles shall receive 4", 3000 PSI concrete cover with 6"x6"x6" gauge welded wire reinforcement.
4. Contractor shall supply to Hampton Roads Sanitation District Systems Engineer three (3) clear copies of tapping saddle manufacturer's catalog cut and installation instructions 14 days prior to installation of saddle.
5. Tapping saddle manufacturer shall be Smith-Blair style 625 or JCM style 415.

NOT TO SCALE



STANDARD DESIGN DETAIL

TAPPING SADDLE FOR CONCRETE CYLINDER PIPE

DRAWING NO. 377
SHEET 1 OF 1
DATE 9/2018

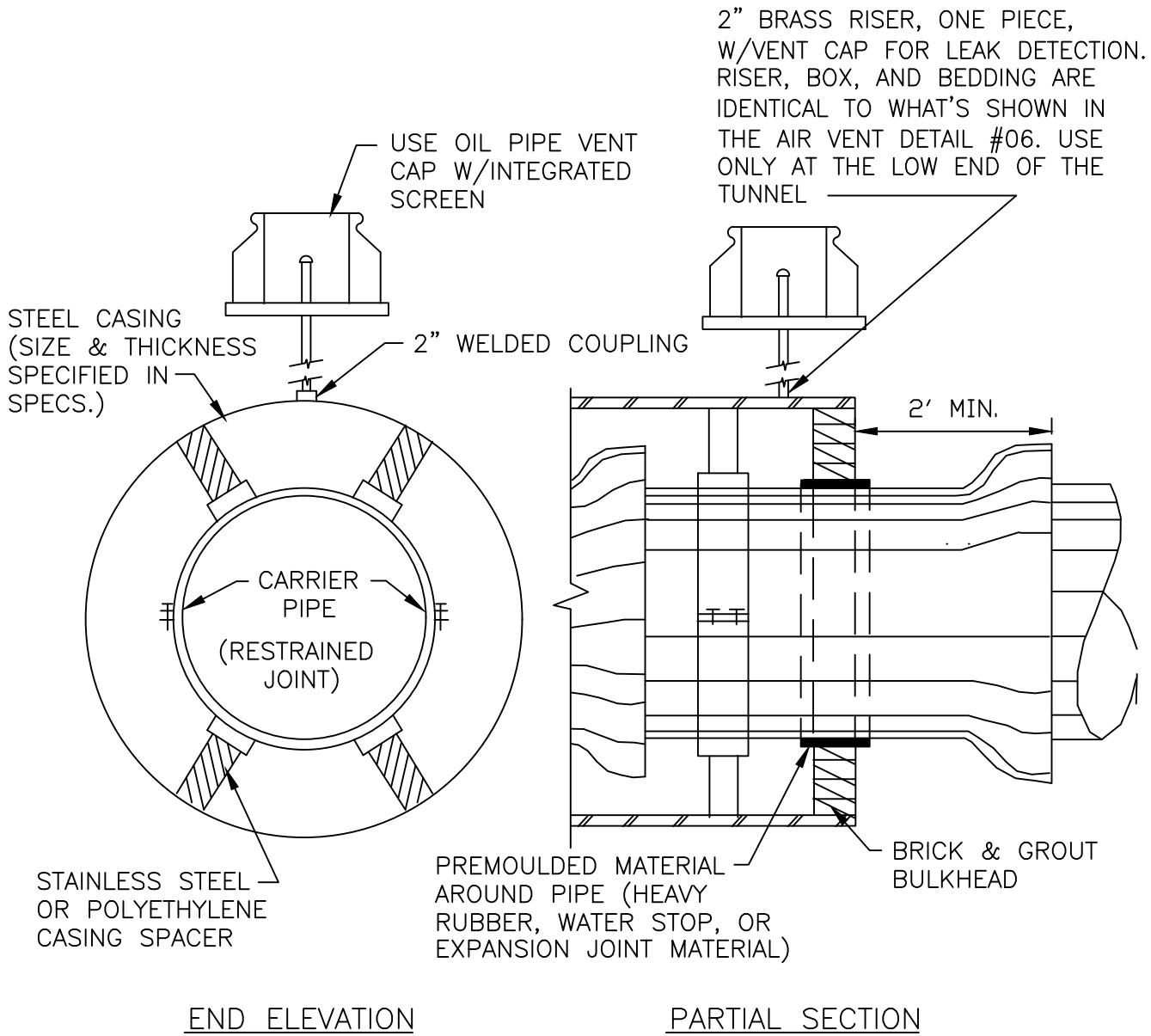

NOTE: INSTALL CASING PIPE AS SHOWN ON DRAWINGS OR MIN. 4' BEYOND EDGE OF PAVEMENT.

NOT TO SCALE

	STANDARD DESIGN DETAIL	DRAWING NO. <b>378A</b>
	STEEL CASING PIPE DETAIL	SHEET <b>1 OF 2</b>
		DATE <b>9/2018</b>

NOTES:

A. STAINLESS STEEL SPACERS

SPACERS SHALL BE BOLT ON STYLE WITH A TWO PIECE SHELL MADE FROM T-304 STAINLESS STEEL OF A MINIMUM 14 GAUGE THICKNESS. THE SHELL SHALL BE LINED WITH A RIBBED P.V.C. SHEET OF A 0.090" THICKNESS THAT OVERLAPS THE EDGES. RUNNERS MADE FROM UHMW POLYMER, SHALL BE ATTACHED TO RISERS AT APPROPRIATE POSITIONS TO PROPERLY LOCATE THE CARRIER WITHIN THE CASING AND TO EASE INSTALLATION. RISERS TO BE MADE FROM T-304 STAINLESS STEEL OF A MINIMUM 14 GAUGE THICKNESS AND SHALL BE ATTACHED TO THE SHELL BY MIG WELDING. ALL WELDS SHALL BE FULLY PASSIVATED. ALL FASTENERS SHALL BE MADE FROM T-304 STAINLESS STEEL CASING SPACERS SHALL BE MODEL CCS AS MANUFACTURED BY CASCADE WATERWORKS MANUFACTURING COMPANY OF YORKVILLE, IL. OR APPROVED EQUAL.

B. HIGH DENSITY POLYETHYLENE

SPACERS SHALL BE PROJECTION TYPE, TOTALLY NON-METALLIC CONSTRUCTED OF PREFORMED SECTIONS OF HIGH-DENSITY POLYETHYLENE AND ISO 9002 CERTIFIED FOR STRENGTH AND QUALITY. SPACERS SHALL PROVIDE SUPPORT AROUND THE PERIPHERY OF THE PIPE. THE MINIMUM NUMBER OF PROJECTIONS AROUND THE CIRCUMFERENCE SHALL TOTAL THE NUMBER OF PIPE DIAMETER INCHES. SPACERS SHALL USE DOUBLE BACK TAPE TO FASTEN TIGHTLY ONTO THE CARRIER PIPE. SPACER SPAN SHALL BE IN ACCORDANCE WITH THE MANUFACTURER'S RECOMMENDATIONS TO PREVENT SAGGING OF THE PIPE. THE MAXIMUM LOAD SHALL NOT EXCEED MANUFACTURER'S RECOMMENDATIONS. SPACERS SHALL HAVE MINIMUM HEIGHT THAT CLEARS THE PIPE BELL OR AS OTHERWISE INDICATED ON THE PLANS. SPACERS SHALL BE MANUFACTURED BY RACI SPACERS NORTH AMERICA INC. OR APPROVED EQUAL.

C. SPACER WIDTH AND PLACEMENT INTERVALS

IN ALL INSTANCES SPACER SHOULD BE PLACED SO AS TO SUPPORT THE CARRIER WITHIN 2' OF THE ENDS OF THE PIPE. CONSULT PIPE MANUFACTURER FOR RECOMMENDATIONS ON SPACER WIDTH AND ADDITIONAL PLACEMENT INTERVALS.

	STANDARD DESIGN DETAIL	DRAWING NO. 378B
	STEEL CASING PIPE DETAIL	SHEET 2 OF 2
		DATE 9/2018

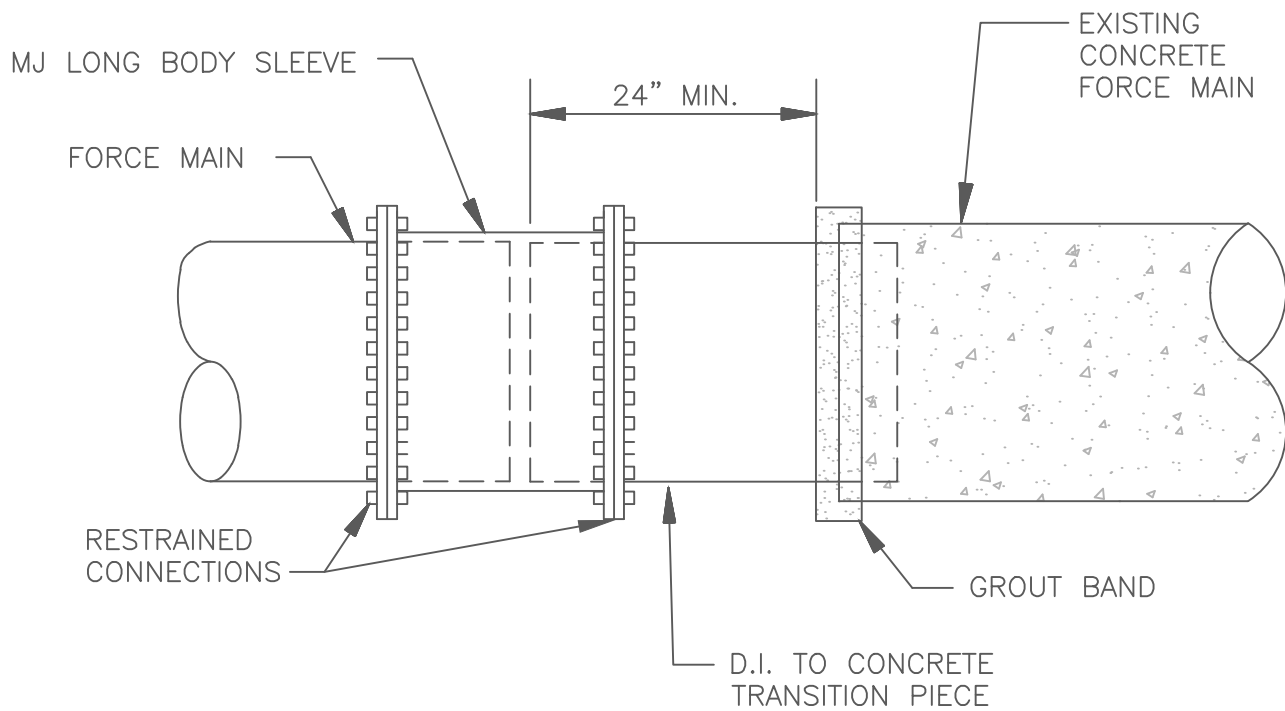

A	B	M.J.S. O.D.
16"	30.0"	17.4"
18"	30.0"	19.5"
20"	30.0"	21.6"
24"	30.0"	25.8"
30"	30.0"	32.0"
36"	30.0"	38.3"
42"	30.0"	44.5"
48"	30.0"	50.8"

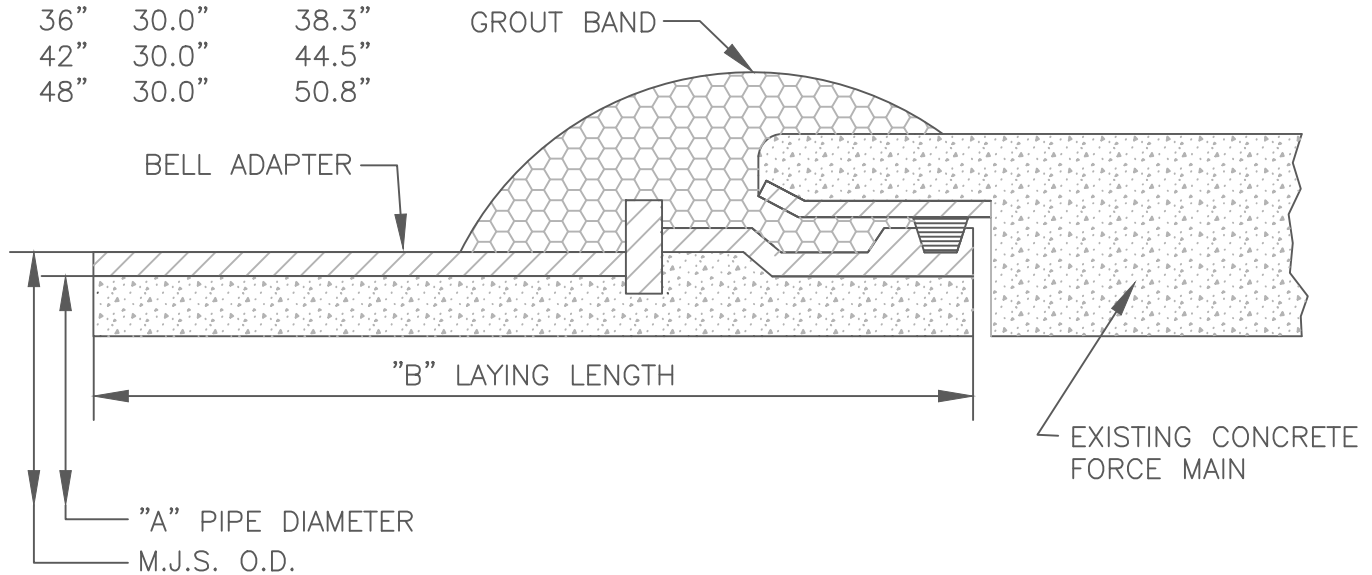

NOT TO SCALE

	STANDARD DESIGN DETAIL	DRAWING NO. <b>379</b>
	D.I. M.J. SPIGOT TO CONCRETE TRANSITION ADAPTER (MALE)	SHEET <b>1 OF 1</b>
		DATE <b>9/2018</b>

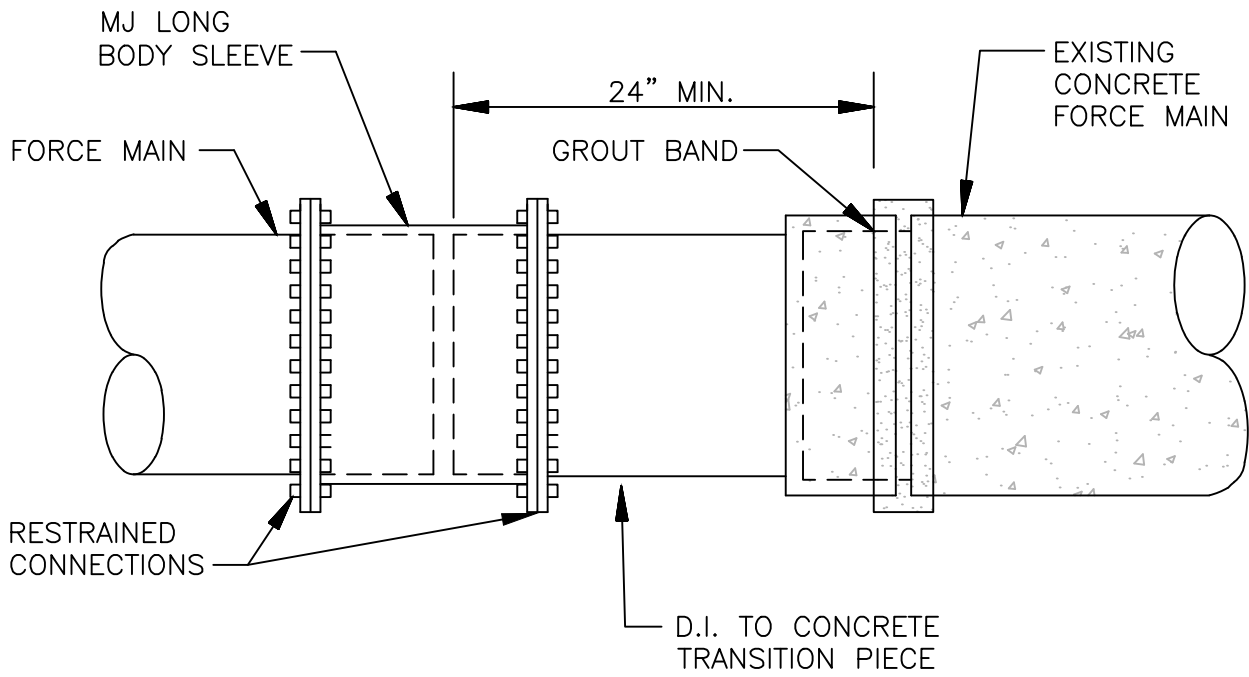

A	B	M.J.S. O.D.
16"	25.5"	17.4"
18"	25.5"	19.5"
20"	25.5"	21.6"
24"	25.5"	25.8"
30"	25.5"	32.0"
36"	25.5"	38.3"
42"	25.5"	44.5"
48"	25.5"	50.8"

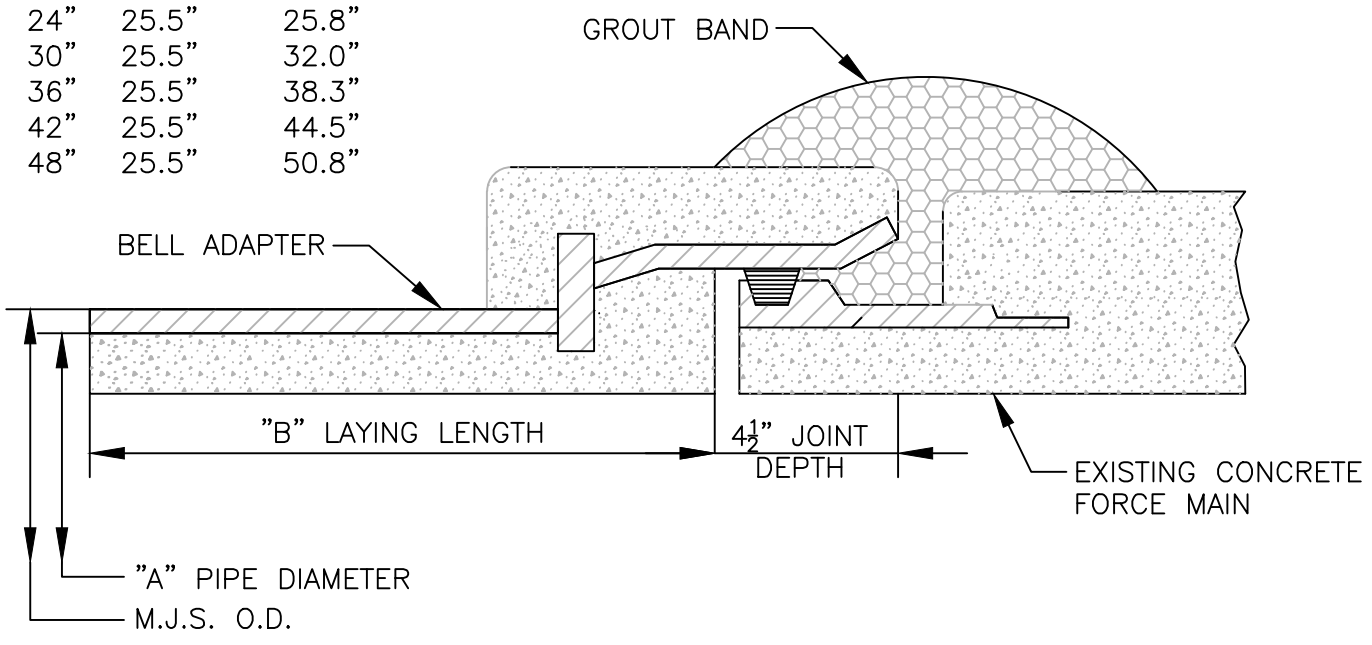

NOT TO SCALE

	STANDARD DESIGN DETAIL	DRAWING NO. <b>380</b>
	D.I. M.J. SPIGOT TO CONCRETE TRANSITION ADAPTER (FEMALE)	SHEET <b>1 OF 1</b>
		DATE <b>9/2018</b>

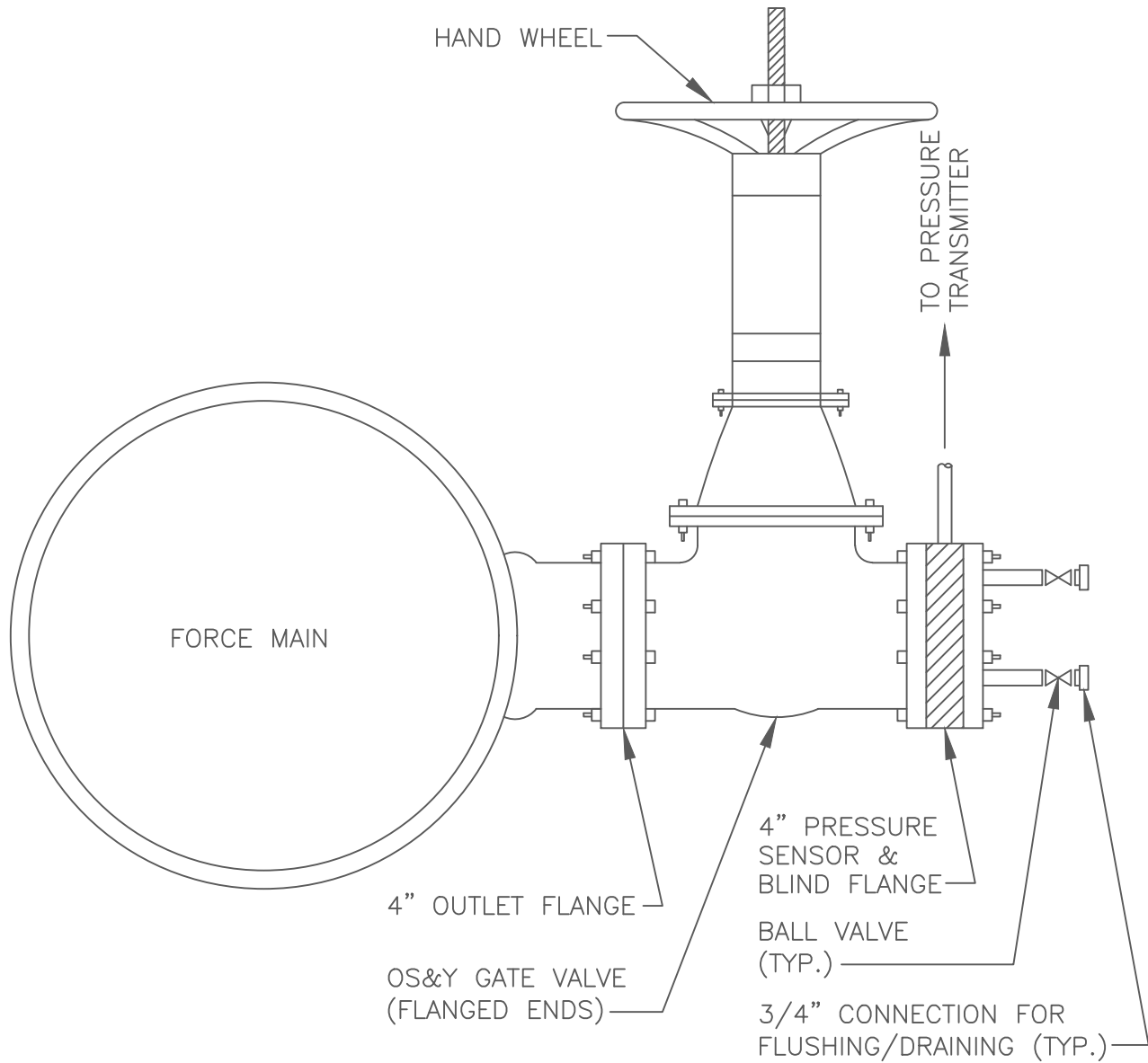

NOTES:

1. THE CENTERLINE OF THE 4" OUTLET FLANGE SHALL BE LOCATED AT THE 3 O'CLOCK POSITION.

NOT TO SCALE

	STANDARD DESIGN DETAIL	DRAWING NO. 381
	PRESSURE SENSOR INSTALLATION	SHEET 1 OF 1
		DATE 9/2018

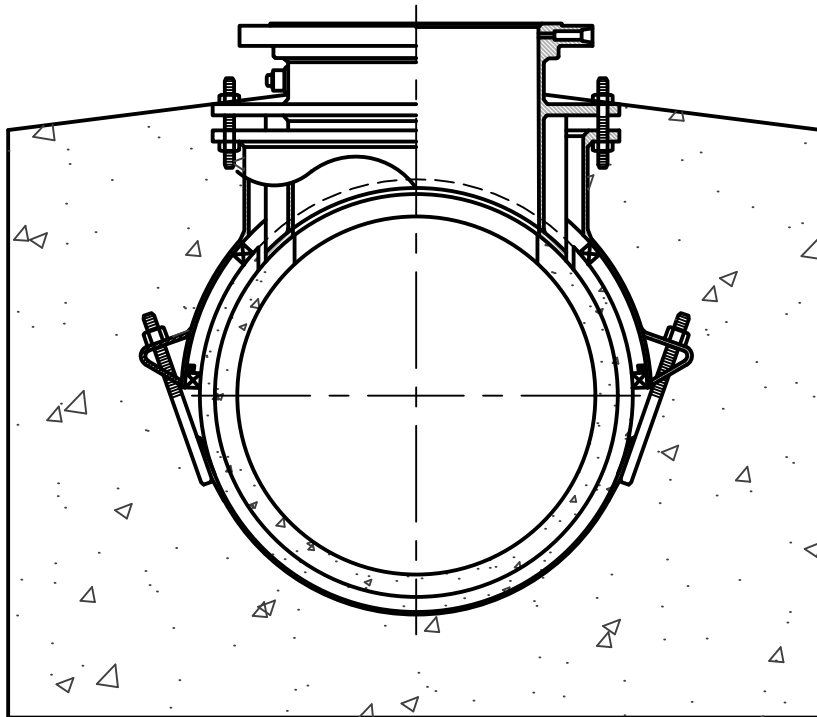

NOT TO SCALE



STANDARD DESIGN DETAIL

CONCRETE CYLINDER PIPE LINE STOP DETAIL

DRAWING NO.  
382

SHEET  
1 OF 1

DATE  
9/2018

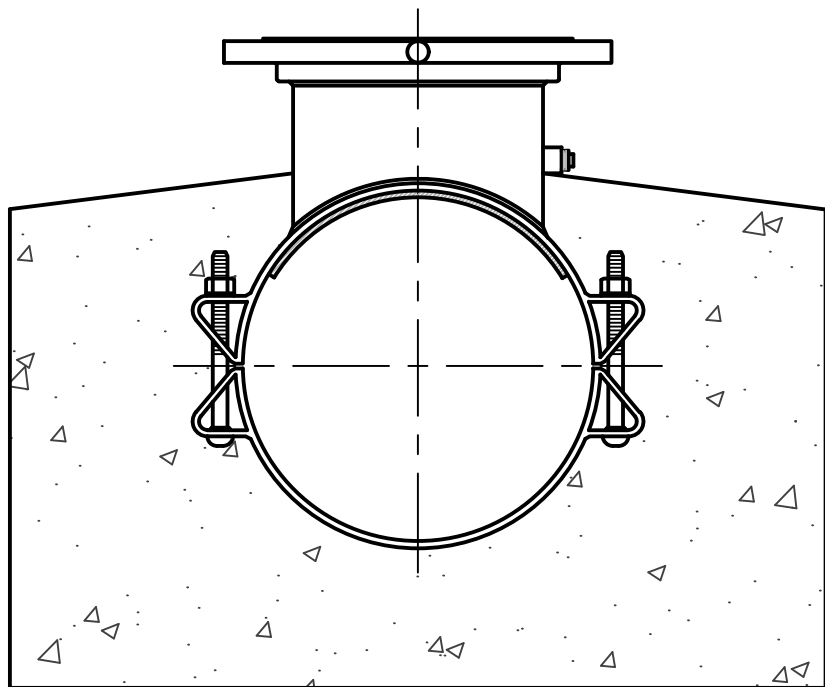

STANDARD DESIGN DETAIL

DUCTILE/CAST IRON PIPE LINE STOP DETAIL

DRAWING NO. 383
SHEET 1 OF 1
DATE 9/2018